

OrbiPlateTM Post Installed Design Guide

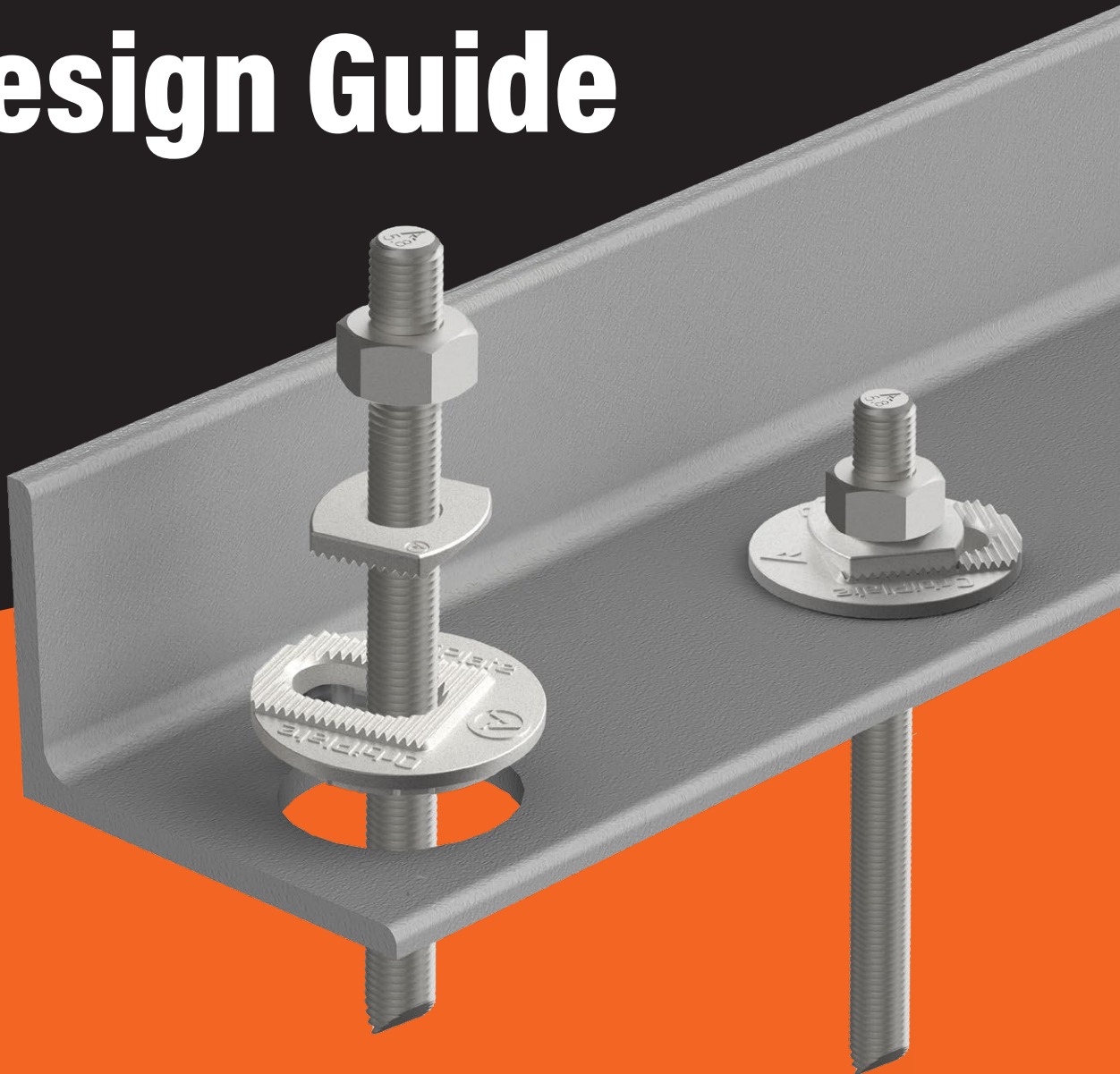

OrbiPlateTM Post Installed offers flexibility with rotational and positional tolerance, making it easier to find drilling locations without hitting reinforcing bars in concrete.

For more information on
our products call
0800 72 67 38
Or go on our website
ramset.co.nz

Applications

The Ramset™ OrbiPlate™ is a versatile solution for a wide range of applications, including straight panel-to-panel connections, corner panel-to-panel connections, roof beam-to-panel connections, raker angle-to-panel connections, and column-to-panel connections. It effectively addresses the common challenge of aligning holes — a task that is often time-consuming, costly, and structurally inadequate with traditional methods.

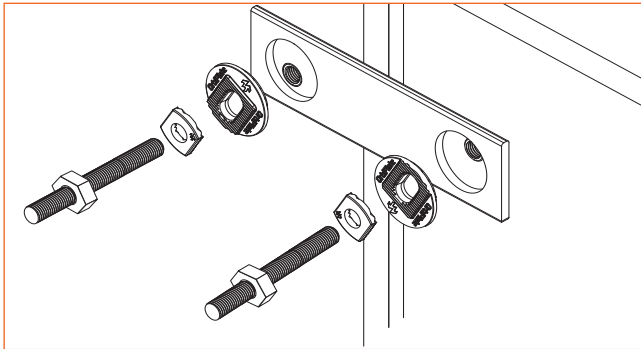

Straight panel to panel connection

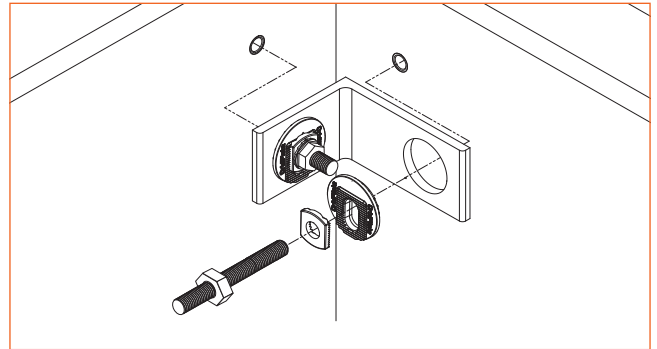

Corner panel to panel connection

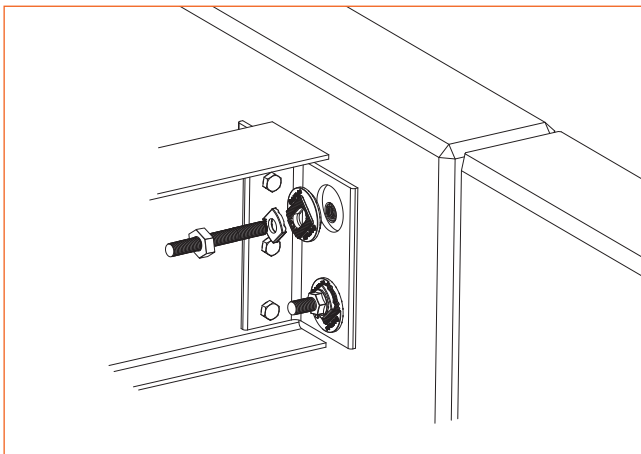

Roof beam to panel connection

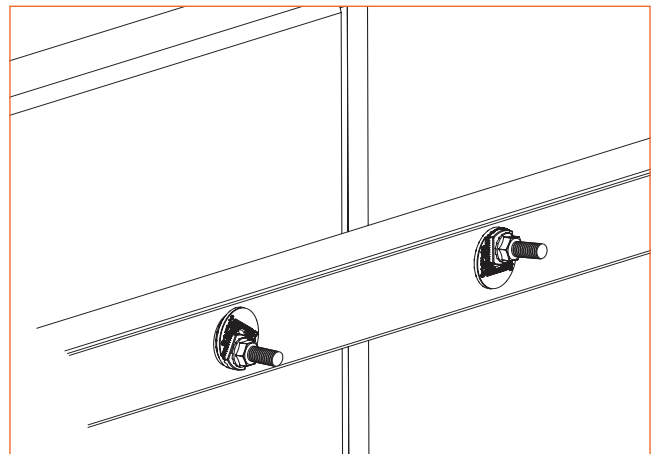

Raker angle to panel connection

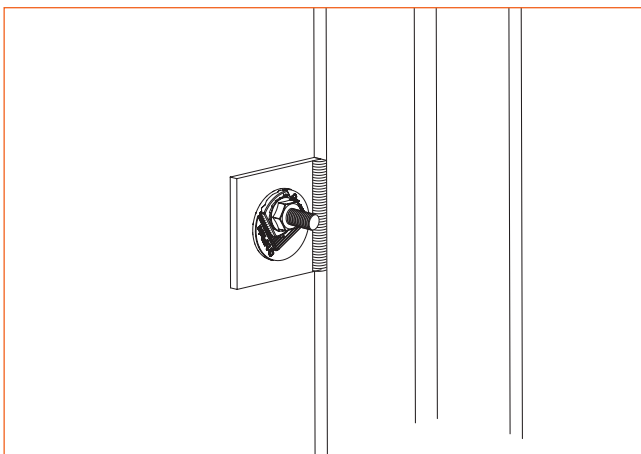

Column to panel connection

Benefits

Ramset Post-Installed OrbiPlate is a smart solution to avoid the challenges of rebar interference while keeping the project efficient and cost-effective. It's a great way to ensure structural integrity and avoid additional costs related to fixture rework and the time delays from redoing drilled holes.

When anchoring into heavily reinforced concrete it is common to encounter rebar when drilling. This can be a serious issue, both for the integrity of the structure and for the work process itself. Drilling through rebar risks compromising the concrete's strength, which could affect the building's overall structural integrity. Additionally, drilling through rebar can be tough on tools, increasing wear and tear and leading to greater costs in the long run due to the need for specialized, stronger bits.

The alternative is to fill the hole with a chemical adhesive, wait for it to cure, and then drill a new hole adjacent to the original hole. However, this approach is time-consuming, involves extra material costs, and requires modifications to the steel fixture, making the process more complicated and expensive.

Using a post-installed OrbiPlate allows the installer to avoid the need to rework rebar by first scanning the concrete and marking out the rebar locations. This step helps the installer avoid drilling directly into the rebar, which can prevent damage to the structure and tools.

The OrbiPlate's 20mm tolerance around the original hole location allows for some flexibility in positioning the new holes. If the installer detects rebar in the original planned location, they can simply shift the hole within that 20mm margin without needing to drastically alter the installation plan. This flexibility saves time and avoids having to redo the work.

If rebar is encountered, rather than continuing to drill through it, the installer can fill the hole with a chemical adhesive. This ensures that the structural integrity of the concrete is not compromised. Once the adhesive cures, the installer can then drill a new hole within the 20mm tolerance allowed by the OrbiPlate, preserving the original fixture alignment without any need to modify or rework the steel fixture itself.

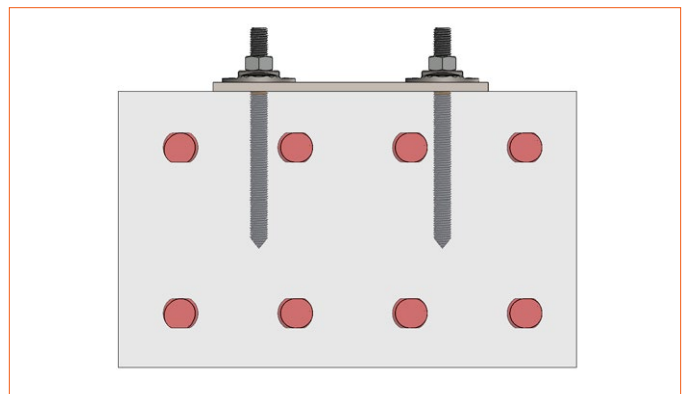
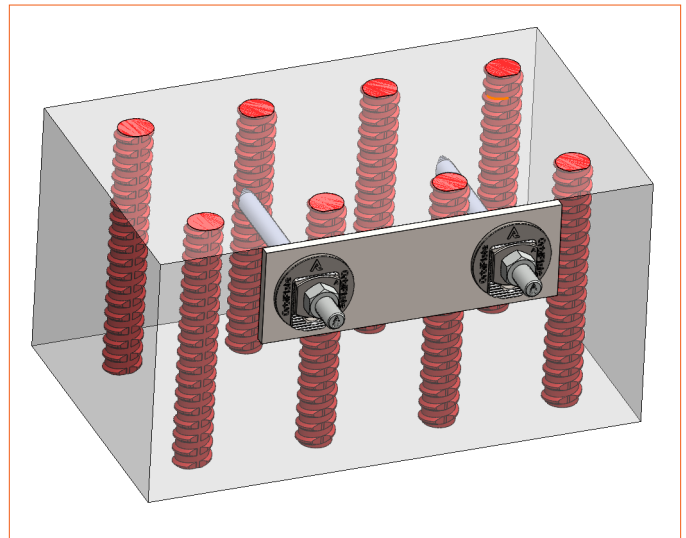
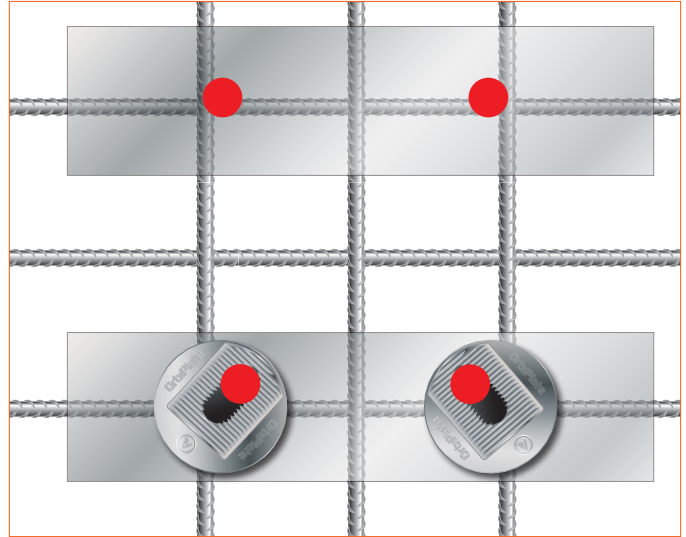

Example of a concrete column to give perspective of the rebar density.

OrbiPlate™ & ChemSet™ Anchor Stud M20 HDG Kit with ChemSet™ Epcon™ G5 Xtrem™

General Information

Product

OrbiPlate™ Post Installed offers flexibility with rotational and positional tolerance, making it easier to find drilling locations without hitting reinforcing bars in concrete.

Compliance

European Technical Assessment (option 1) - ETA-25/0648

Design according to:

- AS 5216 (formerly TS101)
- NZS 1170.5 - Earthquake Actions
- EN 1992-4 (formerly ETAG001 Annex C, E & TR045)
- Use enclosed data for simplified calculation method

Use Ramset™ iExpert Anchor Software for optimised calculation or where a greater range of anchor layout detail is needed.

Feature

- A large washer with an elongated slot surrounded by teeth that lock the smaller washer in place, allowing positioning of the Anchor Stud with up to 20mm misalignment.

Advantages

- Provides 20mm positional tolerance.
- Fine positional adjustment.
- No rotation under shear load.

Benefits

- High structural capacity.
- Allows fine positional adjustment.
- Avoids misalignment delays and call outs.
- No hot work required on site.

Installation

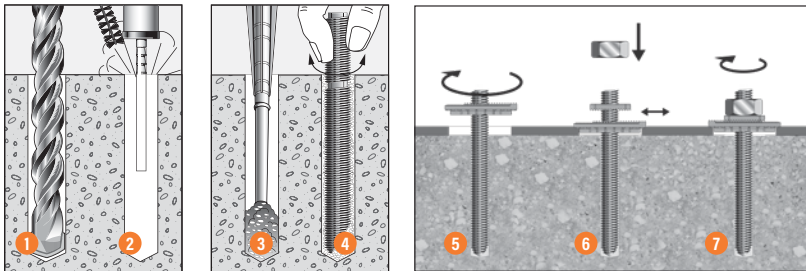

1. Drill recommended diameter and depth hole.
2. **Important:** For hammer drilling technique clean dust and debris from hole with stiff wire brush and blower in the following sequence: blow x 2, brush x 2, blow x 2, brush x 2, blow x 2. For diamond drilling technique refer to ETA-25/0648.
3. Screw mixing nozzle onto cartridge and dispense adhesive to waste until colour is uniform orange. Insert mixing nozzle to bottom of hole. Fill hole to 2/3 the hole depth slowly, ensuring no air pockets form.
4. Insert Ramset™ ChemSet™ Anchor Stud to bottom of hole while turning. Allow ChemSet™ Epcon™ G5 Xtrem™ to cure as per setting times.
5. Place the large washer in the 70mm fixture hole and rotate until the slot lines up with the M20 ChemSet Anchor Stud.
6. Move the small washer along slot until it aligns with the M20 ChemSet Anchor Stud.
7. Attach the nut and tighten to the specified torque.



Performance Related



Material Specification

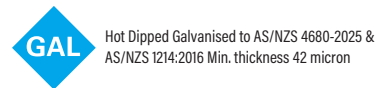

Installation Related



Principal Applications

- Panel to panel fixing
- Raker Angles
- Roof beams to walls
- Steel column to panels

Recommended Installation Temperatures

	Minimum	Maximum
Substrate	5°C	40°C
Adhesive	5°C	40°C

Service Temperature Limits

T1: -40°C to +40°C

T2: -40°C to +60°C

T3: -40°C to +75°C

Setting Times

Temperature of base material	Gel Time	Curing time in dry concrete	Curing time in wet and flooded concrete
5°C	75 min	30h	60 h
10°C	45 min	22h	44 h
15°C	35 min	14h	28 h
20°C	22 min	7h	14 h
25°C	14 min	5h	10 h
30°C	8 min	4h	8 h
35°C	6 min	3h	6h
40°C	4 min	2h 45min	5h 30min

OrbiPlate™ & ChemSet™ Anchor Stud M20 HDG Kit with ChemSet™ Epcon™ G5 Xtrem™ Combination

The following design information is for the OrbiPlate™ & ChemSet Anchor Stud Kit when used in combination with Ramset™ ChemSet™ Epcon™ G5 Xtrem™. This design information is not applicable if OrbiPlate™ is used with other adhesive anchor systems as a reduction in capacity can be expected.

Installation and Performance Details:

Non-Cracked Concrete Design

Anchor size, d_b (mm)	Drilled hole diameter, d_h (mm)	OrbiPlate™ Part Number	Fixture hole diameter, d_f (mm)	Anchor effective depth, h_n (mm)	Tightening torque, T_t (Nm)	Optimum dimensions*		Concrete substrate thickness, b_m (mm)	Reduced Characteristic Capacity#					
						Anchor spacing, a_c (mm)	Edge distance, e_c (mm)		Grade 5.8 Steel Studs		Non-Cracked Concrete			
									Shear, ϕV_{us} (kN)##	Tension, ϕN_{us} (kN)***	Tension, ϕN_{uc} (kN)**			
						Concrete Compressive Strength, f_c								
20 MPa	32 MPa	40 MPa												
M20	25	ORB2020PIAGH	70 ± 1	100	120	300	150	150	49.9	81.3	32.8	41.5	46.5	
				150		450	225				200	60.2	76.2	85.4
				170		510	255				220	72.6	91.9	103.0

*Note: For shear loads acting towards an edge or where these optimum dimensions are not achievable, please use the simplified strength limit state design process to verify capacity.

**Note: Reduced characteristic ultimate concrete tensile capacity = ϕN_{uc} where $\phi = 0.67$ and N_{uc} = Characteristic ultimate concrete tensile capacity.

For conversion to Working Load Limit MULTIPLY ϕN_{uc} x 0.5

***Note: Reduced characteristic ultimate steel tensile capacity = ϕN_{us} where $\phi = 0.67$ and N_{us} = Characteristic ultimate steel tensile capacity.

For conversion to Working Load Limit MULTIPLY ϕN_{us} x 0.67 for Gr 5.8

#Note: Design Tensile Capacity ϕN_{ur} = minimum of ϕN_{uc} and ϕN_{us}

For Cracked Concrete performance, please use the simplified strength limit state design process to verify capacity.

Data is based on a Service temperature limit of -40°C to +40°C

All data relevant for Dry and Wet Holes. For Flooded Holes MULTIPLY ϕN_{uc} x 0.63

##Note: Shear capacity based on overall fixture thickness up to and including 16mm. For fixture thickness greater than 16mm and up to and including 32mm multiply ϕV_{us} by 0.70.

Seismic Design

Anchor size, d_b (mm)	Drilled hole diameter, d_h (mm)	OrbiPlate™ Part Number	Fixture hole diameter, d_f (mm)	Anchor effective depth, h_n (mm)	Tightening torque, T_t (Nm)	Optimum dimensions*		Concrete substrate thickness, b_m (mm)	Reduced Characteristic Capacity										
						Anchor spacing, a_c (mm)	Edge distance, e_c (mm)		Grade 5.8 Steel Studs				Seismic C1 & C2 Cracked Concrete tensile capacity, $N_{Rd,s,seis}^0$ (kN)**						
									Shear, $V_{Rd,seis}$ (kN)##		Tension, $N_{Rd,s,seis}$ (kN)***		Concrete Compressive Strength, f_c						
						C1			C2		C1		C2		C1		C2		C1
M20	25	ORB2020PIAGH	70 ± 1	100	120	300	150	150	171	16.7	81.3	81.3	17.2	13.5	21.1	13.5	24.3	13.5	
				150		450	225						200	31.6	20.3	38.7	20.3	44.7	20.3
				170		510	255						220	38.2	23.0	46.7	23.0	54.0	23.0

* For anchor spacings or edge distances less than the minimum, please refer to the simplified strength limit state design process to verify capacity.

** Tension values are based on service temperature limits -40°C to +40°C only. If service temperature limits is beyond this range please contact Ramset Engineer.

** Note: Seismic Cracked concrete combined pull-out and concrete cone resistance, tension = $N_{Rd,s,seis}^0 = \alpha_{seis} N_{Rk,s,seis}^0 / \gamma_{Mse}$ where $\gamma_{Mse} = 1.5$

***Note: Seismic Cracked Concrete steel resistance, tension = $N_{Rd,s,seis} = \alpha_{seis} N_{Rk,s,seis} / \gamma_{Ms}$ (kN) where $\gamma_{Ms} = 1.5$ (Grade 5.8 steel)

Note: Shear Data includes annular gap reduction factor of 0.5

For optimised performance data, including performance based on diamond drilling technique, please use Ramset iExpert Anchoring Software.

Description And Part Numbers

OrbiPlate™ Kit

Anchor size, d_b (mm)	Description		Part No.
	Washer OD (mm)	Fixture hole (mm)	Gal
M20 x Serrated Plates	80	70 ± 1	ORB2020PIAGH
	ChemSet Anchor Stud Galvanised		
M20 x 240			

ChemSet™ Adhesive Anchoring System Design

Description	Size	Part No.
ChemSet™ Epcon™ G5 Xtrem™	600ml	CEG5X600

Engineering Properties

OrbiPlate™ and ChemSet™ Anchor Stud Combination

Anchor Stud Size, d_b	Overall Length, L (mm)	Effective Length, L_e (mm)	Max Fixture Thickness, t (mm)	Stress Area, A_s (mm ²)	Grade 5.8 Steel Studs		Section Modulus, Z (mm ³)
					Yield Strength, f_y (MPa)	Carbon Steel UTS, f_u (MPa)	
M20	240	225	32	232.4	420	520	540.9

Strength Limit State Design / OrbiPlate™ with M20 ChemSet™ Anchor Stud with ChemSet™ Epcon™ G5 Xtrem™

STEP 1

Select anchor to be evaluated

Table 1a - Indicative combined loading - interaction diagram

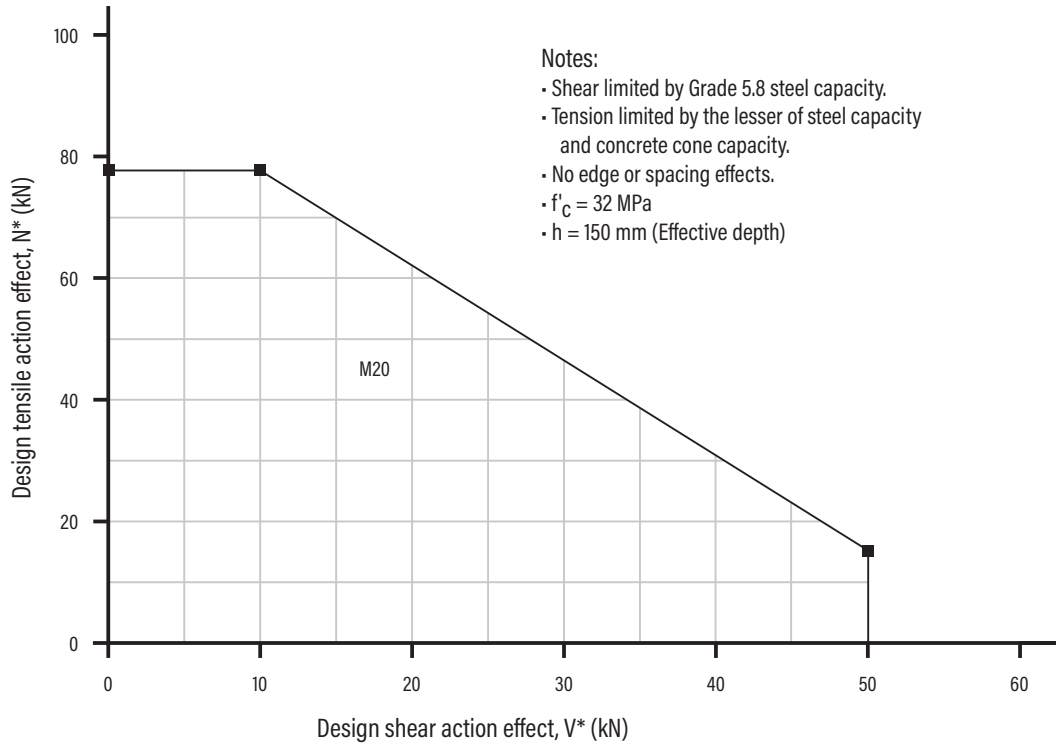

Table 1b - Absolute minimum edge distance and anchor spacing values, e_m and a_m (mm)

Anchor Stud Size, d_b	M20
e_m	55
a_m	85

Step 1c Calculate anchor effective depth, h (mm)

Effective depth, h (mm)
 Preferred $h = h_n$ otherwise,
 $h = L_e - t$
 t = total thickness of material(s) being fastened.

Substrate thickness b_m (mm)
Anchor Stud Size (mm)
M20
$h + (2 \times d_n)$

CHECK POINT **1**

Anchor size determined, absolute minima compliance achieved.

Strength Limit State Design / OrbiPlate™ with M20 ChemSet™ Anchor Stud with ChemSet™ Epcon™ G5 Xtrem™

STEP 1

Verify concrete tensile capacity - per anchor

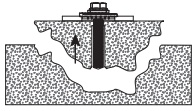

Table 2a - Reduced characteristic ultimate concrete tensile capacity, ϕN_{uc} (kN), $\phi_c = 1/1.5 = 0.67$, $f'_c = 32$ MPa

Fixing System	OrbiPlate™ with M20 ChemSet™ Galvanised Anchor Stud installed with ChemSet™ Epcon™ G5 Xtrem™										
Effective depth h, (mm)	100	150	160	170	180*	200*	240*	280*	320*	350*	400*
Bond - ϕN_{ucp} (kN)	68.5	102.7	109.6	116.4	123.3	137.0	164.4	191.8	219.2	239.7	274.0
Concrete Cone - ϕN_{ucc} (kN)	41.5	76.2	84.0	91.9	100.2	117.3	154.2	194.4	237.5	271.6	331.9

*Note: For effective depth 180mm and greater please use typical threaded rod with minimum grade 5.8 and cut to length.

Table 2a-2 - Cracked Concrete or Seismic effect, tension, $X_{n,cr,seis}$

Condition	Non-Cracked Concrete	Cracked Concrete	Seismic Cracked Concrete	
			C1	C2
			for Bond $\phi N_{uc} = \phi N_{ucp}$	1.00
for Concrete Cone $\phi N_{uc} = \phi N_{ucc}$	1.00	0.70	0.52	0.52

Calculate ϕN_{urc} for both ϕN_{ucp} and ϕN_{ucc} then choose the minimum - Refer to Checkpoint 2

Table 2b - 1 - Concrete service temperature limits effect, tension, X_{ns}

Service Temperature (°C)	Service Temperature limits effect, tension, X_{ns}
T1: -40°C to +40°C	1.00
T2: -40°C to +60°C	0.84
T3: -40°C to +75°C	0.26

Table 2b - 2 - Concrete compressive strength effect, tension, X_{nc}

Condition	Non-Cracked Concrete	OrbiPlate™ with M20 ChemSet™ Galvanised Anchor Stud installed with ChemSet™ Epcon™ G5 Xtrem™				
		20	25	32	40	50
* for Bond $\phi N_{uc} = \phi N_{ucp}$	0.87	0.93	1.00	1.07	1.14	
	Cracked Concrete	0.91	0.95	1.00	1.05	1.09
for Concrete Cone $\phi N_{uc} = \phi N_{ucc}$ for Non-Cracked Concrete & Cracked Concrete		0.79	0.88	1.00	1.12	1.25

* Note: For Seismic cracked concrete conditions (C1 & C2), where bond is governing ($\phi N_{uc} = \phi N_{ucp}$), $X_{nc} = 1.00$

Table 2c - Edge distance effect, tension, X_{ne}

Fixing System	OrbiPlate™ with M20 ChemSet™ Galvanised Anchor Stud installed with ChemSet™ Epcon™ G5 Xtrem™									
Edge distance, e (mm)	55	65	70	90	100	115	135	165	187	255
Effective Depth, h (mm)										
100	0.52	0.58	0.60	0.70	0.75	0.83	0.93	1.00	1.00	1.00
150	0.43	0.47	0.48	0.55	0.58	0.63	0.70	0.80	0.87	1.00
170	0.41	0.44	0.46	0.51	0.54	0.59	0.65	0.74	0.80	1.00
200	0.39	0.41	0.43	0.48	0.50	0.54	0.59	0.66	0.72	0.89
280	0.35	0.37	0.38	0.41	0.43	0.46	0.49	0.54	0.58	0.71

Table 2d - Anchor spacing effect, tension, X_{na}

Fixing System	OrbiPlate™ with M20 ChemSet™ Galvanised Anchor Stud installed with ChemSet™ Epcon™ G5 Xtrem™								
Anchor spacing, a (mm)	85	90	140	170	200	270	330	375	510
Effective Depth, h (mm)									
100	0.64	0.65	0.73	0.78	0.83	0.95	1.00	1.00	1.00
150	0.59	0.60	0.66	0.69	0.72	0.80	0.87	0.92	1.00
170	0.58	0.59	0.64	0.67	0.70	0.76	0.82	0.87	1.00
200	0.57	0.58	0.62	0.64	0.67	0.73	0.78	0.81	0.93
280	0.55	0.55	0.58	0.60	0.62	0.66	0.70	0.72	0.80

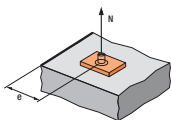

$X_{ne} = 0.25 + 0.5*(e/h)$
Where $e_m \leq e \leq e_c$
 $e_c = 1.5*h$

Note: Tabled values are based on the nominal effective depth, h shown in the installation details. For other values of X_{ne} , please use equation shown above.

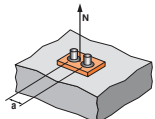

$X_{na} = 0.5 + a/(6*h)$
Where $a_m \leq a \leq a_c$
 $a_c = 3*h$

Note: Tabled values are based on the nominal effective depth, h shown in the installation details. For other values of X_{na} , please use equation shown above.

CHECK POINT 2

Design reduced ultimate tensile capacity, ϕN_{urc}
 $\phi N_{urc} = \text{minimum of } \phi N_{ucp} * X_{n,cr,seis} * X_{ns} * X_{nc} * X_{ne} * X_{na} \text{ and } \phi N_{ucc} * X_{n,cr,seis} * X_{ns} * X_{nc} * X_{ne} * X_{na}$

Strength Limit State Design / OrbiPlate™ with M20 ChemSet™ Anchor Stud with ChemSet™ Epcon™ G5 Xtrem™

STEP 3

Verify anchor tensile capacity - per anchor



Table 3a - Reduced characteristic ultimate steel tensile capacity, ϕN_{us} (kN) where $\phi_n = 0.67$ for Gr 5.8

Anchor Size, d_b	M20
ChemSet™ Anchor Stud Grade 5.8 Galv. Carbon Steel	81.3

Note: Tensile Steel Capacity is also applicable for Seismic Category C1 and C2 conditions.

CHECK POINT 3

Design reduced ultimate tensile capacity, ϕN_{ur}

$$\phi N_{ur} = \text{minimum of } \phi N_{urc}, \phi N_{us}$$

Check $N^* / \phi N_{ur} \leq 1$,

if not satisfied return to step 1

Strength Limit State Design / OrbiPlate™ with M20 ChemSet™ Anchor Stud with ChemSet™ Epcon™ G5 Xtrem™

STEP 4

Verify concrete shear capacity - per anchor



Table 4a - Reduced characteristic ultimate concrete edge shear capacity, ϕV_{uc} (kN), $\phi = 1/1.5 = 0.67 f'_c = 32$ MPa

Anchor Size, d_a	M20			
Effective depth, h (mm)	100	150	170	180-400
Edge distance, e_m (mm)				
55	8.1	9.1	9.5	9.7

Table 4a - 1 - Cracked Concrete or Seismic effect, tension, $X_{v,cr,seis}$

Fixing System	OrbiPlate™ with M20 ChemSet™ Galvanised Anchor Stud installed with ChemSet™ Epcon™ G5 Xtrem™			
Condition	Non-Cracked Concrete	Cracked Concrete	Seismic Cracked Concrete	
			C1	C2
$X_{v,cr,seis}$	1.00	0.71	0.30	0.30

Note: Seismic effect for C1 & C2 includes annular gap reduction factor of 0.5.

Table 4b - Concrete compressive strength effect, concrete edge shear, X_{vc}

Fixing System	OrbiPlate™ with M20 ChemSet™ Galvanised Anchor Stud installed with ChemSet™ Epcon™ G5 Xtrem™				
f'_c (MPa)	20	25	32	40	50
Condition					
X_{vc}	0.79	0.86	1.00	1.11	1.22

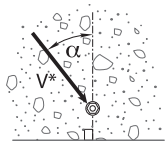

Load direction effect, conc. edge shear, X_{vd}

Table 4c - Load direction effect, concrete edge shear, X_{vd}

Angle, α°	0-55	60	70	80	90-180
X_{vd}	1.0	1.1	1.2	1.5	2.0

Table 4d - Concrete anchor spacing and edge distance effect, concrete edge shear, X_{ve}

For single anchor fastening X_{ve}

e/e_m	1.0	1.2	1.4	1.6	1.8	2.0	2.2	2.4	2.6	2.8	3.0	3.2
X_{ve}	1.00	1.31	1.66	2.02	2.41	2.83	3.26	3.72	4.19	4.69	5.20	5.72

For 2 anchors fastening X_{ve}

e/e_m	1.0	1.2	1.4	1.6	1.8	2.0	2.2	2.4	2.6	2.8	3.0	3.2	
a/e_m													
1.0	0.67	0.84	1.03	1.22	1.43	1.65	1.88	2.12	2.36	2.62	2.89	3.16	
1.5	0.75	0.93	1.12	1.33	1.54	1.77	2.00	2.25	2.50	2.76	3.03	3.31	
2.0	0.83	1.02	1.22	1.43	1.65	1.89	2.12	2.38	2.63	2.90	3.18	3.46	
2.5	0.92	1.11	1.32	1.54	1.77	2.00	2.25	2.50	2.77	3.04	3.32	3.61	
3.0	1.00	1.20	1.42	1.64	1.88	2.12	2.37	2.63	2.90	3.18	3.46	3.76	
3.5		1.30	1.52	1.75	1.99	2.24	2.50	2.76	3.04	3.32	3.61	3.91	
4.0			1.62	1.86	2.10	2.36	2.62	2.89	3.17	3.46	3.75	4.05	
4.5				1.96	2.21	2.47	2.74	3.02	3.31	3.60	3.90	4.20	
5.0					2.33	2.59	2.87	3.15	3.44	3.74	4.04	4.35	
5.5						2.71	2.99	3.28	3.71	4.02	4.33	4.65	
6.0							2.83	3.11	3.41	3.71	4.02	4.33	4.65

For 3 anchors fastening and more

$$X_{ve} = \frac{3 \cdot e + a_1 + a_2 + a_3 + \dots + a_{n-1}}{3 \cdot n \cdot e_m} \cdot \sqrt{e/e_m}$$

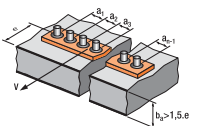
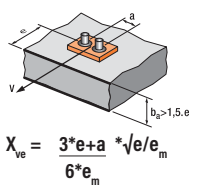
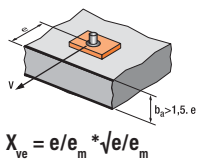

Strength Limit State Design / OrbiPlate™ with M20 ChemSet™ Anchor Stud with ChemSet™ Epcon™ G5 Xtrem™

STEP 4

continued

Table 4e - Reduced characteristic ultimate concrete pryout capacity, ϕV_{ucp} (kN), $\phi = 1/1.5 = 0.67, f'_c = 32$ MPa

Anchor size, d_b	OrbiPlate™ with M20 ChemSet™ Galvanised Anchor Stud installed with ChemSet™ Epcon™ G5 Xtrem™			
Effective depth, h (mm)	Non-Cracked Concrete	Cracked Concrete	Seismic C1	Seismic C2
100	83.0	58.1	21.1	11.9
150	152.4	106.7	38.7	17.9
170	183.9	128.7	46.7	20.3
200	234.7	164.3	57.8	23.9
280	383.5	249.3	80.9	33.4

Note: Seismic effect for C1 & C2 includes annular gap reduction factor of 0.5

Table 4f - Anchor at a corner effect, concrete edge shear, X_{vs}

Note: For $e_1/e_2 > 1.25, X_{vs} = 1.0$

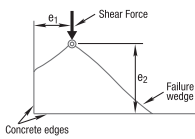

Edge distance, e_2 (mm)	55	60	75	125	200	300	400	600	900
Edge distance, e_1 (mm)									
55	0.86	0.81	0.71	0.55	0.45	0.40	0.37	0.35	0.33
60	0.97	0.86	0.75	0.57	0.47	0.41	0.38	0.36	0.34
75	1.00	1.00	0.86	0.64	0.51	0.44	0.41	0.37	0.35
125	1.00	1.00	1.00	0.86	0.65	0.53	0.48	0.42	0.38
200	1.00	1.00	1.00	1.00	0.86	0.67	0.58	0.49	0.42
300	1.00	1.00	1.00	1.00	1.00	0.86	0.72	0.58	0.49
400	1.00	1.00	1.00	1.00	1.00	1.00	0.86	0.67	0.55
500	1.00	1.00	1.00	1.00	1.00	1.00	1.00	0.77	0.61
600	1.00	1.00	1.00	1.00	1.00	1.00	1.00	0.86	0.67
900	1.00	1.00	1.00	1.00	1.00	1.00	1.00	1.00	0.86

CHECK POINT 4a

Design reduced ultimate concrete edge shear capacity, ϕV_{urc}

$$\phi V_{urc} = \phi V_{uc} * X_{v,\alpha,seis} * X_{vc} * X_{vd} * X_{ve} * X_{vs}$$

CHECK POINT 4b

Design reduced ultimate pryout capacity, ϕV_{urcp}

$$\phi V_{urcp} = \phi V_{ucp} * X_{nc} * X_{ne} * X_{na} * X_{ns}$$

STEP 5

Verify anchor shear capacity - per anchor

Table 5a - Reduced characteristic ultimate steel shear capacity, ϕV_{us} (kN) where $\phi_v = 0.67$ and $\phi V_{us,seis}$ (kN) where $\phi_{vs} = 0.8$

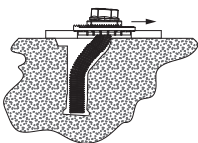

OrbiPlate™ with M20 ChemSet™ Galvanised Anchor Stud	Reduced Char, steel shear, ϕV_{us}		Reduced Char, seismic steel shear, $\phi V_{us,seis}$				
	Non-Cracked/Cracked Concrete		Seismic Category C1 & C2				
	Fixture Thickness (mm)		Fixture Thickness (mm)				
	6 to 16	16 > to 32	6 to 16		16 > to 32		
				Seismic C1	Seismic C2	Seismic C1	Seismic C2
ORB2020PIAGH	49.9	35.3	17.1	16.7	12.0	11.7	

Note: Seismic effect for C1 & C2 includes annular gap reduction factor of 0.5

Strength Limit State Design / OrbiPlate™ M20 ChemSet™ Anchor Stud with ChemSet™ Epcon™ G5 Xtrem™

CHECK POINT 5

Design reduced ultimate shear capacity, ϕV_{ur}

$\phi V_{ur} = \text{minimum of } \phi V_{urc}, \phi V_{urcp}, \phi V_{us} \text{ or } \phi V_{us,seis}$

Check $V^* / \phi V_{ur} \leq 1$,

if not satisfied return to step 1

STEP 6

Combined loading and specification

CHECK POINT 6

Check

$N^* / \phi N_{ur} + V^* / \phi V_{ur} \leq 1.2$,

if not satisfied return to step 1

HOW TO SPECIFY

Ramset™ OrbiPlate™ M20 HDG POST INSTALLED ANCHOR KIT - ORB2020PIAGH

ChemSet™ Epcon™ G5 Xtrem™ (NZ) - CEG5X600

Drill Hole Depth to be (h) mm. To be installed according to Ramset™ Installation Instructions

EXAMPLE

Ramset™ OrbiPlate™ M20 HDG POST INSTALLED ANCHOR KIT - ORB2020PIAGH

New Zealand

ChemSet™ Epcon™ G5 Xtrem™ CEG5X600

Drill Hole Depth to be 170mm.

To be installed according to Ramset™ Installation Instructions

Please refer to Ramset™ product guides for the full range of products available.

Note: It is the Design Engineer's responsibility to ensure that the fixture plate is adequate for the design loads in accordance with AS 4100 / AS 5216:2026 / NZS 3404 / NZS 3101:2006 (A3) Chapter 17

Important Disclaimer: Any engineering information or advice ("Information") provided by Ramset™ in this document is issued in accordance with a prescribed standard, published performance data or design software. It is the responsibility of the user to obtain its own independent engineering (or other) advice to assess the suitability of the Information for its own requirements. To the extent permitted by law, Ramset™ will not be liable to the recipient or any third party for any direct or indirect loss or liability arising out of, or in connection with, the Information.

Customer Service

Ramset™ New Zealand
Sales, Orders and Enquiries
Tel: 0800 726 738
Email: info@ramset.co.nz
Web: www.ramset.co.nz

Website:
NZ: www.ramset.co.nz



**Keep up to date with
Ramset™ on our socials'**



Ramset™ 1 Ramset Drive, Chirside Park 3116

Information in this document is correct at the time of printing. Readers should contact Ramset™ or consult Ramset™ detailed technical information to ensure product is suitable for intended use prior to purchase. ITW Australia Pty Ltd ABN 63 004 235 063 trading as Ramset™
© Copyright 2025.™ Trademarks of Cetram Pty. Ltd. Used under license by Ramset™

ITW1523 CB1523

