

Public-law institution jointly founded by the federal states and the Federation

European Technical Assessment Body
for construction products



European Technical Assessment

ETA-18/0154
of 26 April 2024

English translation prepared by DIBt - Original version in German language

General Part

Technical Assessment Body issuing the European Technical Assessment:

Deutsches Institut für Bautechnik

Trade name of the construction product

Injection system RAMSET Chemset™ 801 Xtrem™/
RAMSET Chemset™ 800 Xtrem™

Product family
to which the construction product belongs

System for post-installed
rebar connection with mortar

Manufacturer

ITW Australia (Ramset)
1 Ramset Drive
Chirnside Park
VIC 3116
AUSTRALIEN

Manufacturing plant

ITW Australia

This European Technical Assessment
contains

22 pages including 3 annexes which form an integral part
of this assessment

This European Technical Assessment is
issued in accordance with Regulation (EU)
No 305/2011, on the basis of

EAD 330087-01-0601, Edition 06/2021

This version replaces

ETA-18/0154 issued on 16 July 2021

The European Technical Assessment is issued by the Technical Assessment Body in its official language. Translations of this European Technical Assessment in other languages shall fully correspond to the original issued document and shall be identified as such.

Communication of this European Technical Assessment, including transmission by electronic means, shall be in full. However, partial reproduction may only be made with the written consent of the issuing Technical Assessment Body. Any partial reproduction shall be identified as such.

This European Technical Assessment may be withdrawn by the issuing Technical Assessment Body, in particular pursuant to information by the Commission in accordance with Article 25(3) of Regulation (EU) No 305/2011.

Specific Part

1 Technical description of the product

The subject of this European Technical Assessment is the post-installed connection, by anchoring or overlap connection joint, of reinforcing bars (rebars) in existing structures made of normal weight concrete, using the injection system "RAMSET Chemset™ 801 Xtrem™" or "RAMSET Chemset™ 800 Xtrem™" in accordance with the regulations for reinforced concrete construction.

Ribbed reinforcing bars made of steel with a diameter ϕ from 8 to 32 mm according to Annex A and the injection mortar "CHEMSET™ 800 XTREM™" or "CHEMSET™ 801 XTREM™" are used for rebar connections. The rebar is placed into a drilled hole filled with injection mortar and is anchored via the bond between rebar, injection mortar and concrete.

The product description is given in Annex A.

2 Specification of the intended use in accordance with the applicable European assessment Document

The performances given in Section 3 are only valid if the rebar connection is used in compliance with the specifications and conditions given in Annex B.

The verifications and assessment methods on which this European Technical Assessment is based lead to the assumption of a working life of the rebar connections of at least 50 and/or 100 years. The indications given on the working life cannot be interpreted as a guarantee given by the producer, but are to be regarded only as a means for choosing the right products in relation to the expected economically reasonable working life of the works.

3 Performance of the product and references to the methods used for its assessment

3.1 Mechanical resistance and stability (BWR 1)

| Essential characteristic | Performance |
|---|-----------------------|
| Characteristic resistance under static and quasi-static loading | See Annex C 1 to C 3 |
| Characteristic resistance under seismic loading | See Annex B 4 and C 4 |

3.2 Safety in case of fire (BWR 2)

| Essential characteristic | Performance |
|--------------------------|---------------|
| Reaction to fire | Class A1 |
| Resistance to fire | See Annex C 5 |

4 Assessment and verification of constancy of performance (AVCP) system applied, with reference to its legal base

In accordance with European Assessment Document EAD No. 330087-01-0601, the applicable European legal act is: [96/582/EC].

The system to be applied is: 1

5 Technical details necessary for the implementation of the AVCP system, as provided for in the applicable European Assessment Document

Technical details necessary for the implementation of the AVCP system are laid down in the control plan deposited with Deutsches Institut für Bautechnik.

Issued in Berlin on 26 April 2024 by Deutsches Institut für Bautechnik

Dipl.-Ing. Beatrix Wittstock
Head of Section

beglaubigt:
Baderschneider

Injection mortar

Injection mortar CHEMSET™ 800 XTREM™, CHEMSET™ 801 XTREM™ 380 ml and 750 ml:
Vinylester adhesive two components

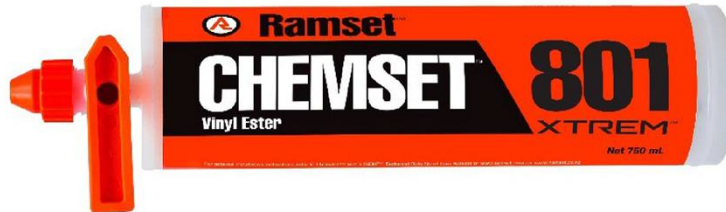

Marking

Trade name

CHEMSET™ 800 XTREM™ (Regular Version)
CHEMSET™ 801 XTREM™ (Tropical Version)

Expire date

Curing and processing time
Charge code number

Identifying mark of the producer **Ramset**

Static mixer

ISNP mixing nozzle



ISNE mixing nozzle



High flow mixing nozzle



Injection system

RAMSET Chemset™ 801 Xtrem™ / RAMSET Chemset™ 800 Xtrem™

Product description

Injection system Chemset™ 801 Xtrem™ / RAMSET Chemset™ 800 Xtrem™

Annex A1

Figure A1: Ribbed reinforcing bar (rebar):

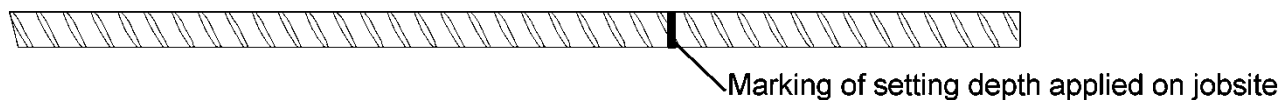

Properties of the ribbed reinforcing bar (rebar):

- Rebar according to EN 1992-1-1:2011 Annex C
- Bars or de-coiled rods class B or C
- Nominal diameter ϕ : 8 to 32 mm
- Rib height h in the range of $0,05 \phi \leq h \leq 0,07 \phi$
- Yield strength f_{yk} and k according to NDP or NCI of EN 1992-1-1/NA
- Ultimate strength $f_{uk} = f_{tk} = k \cdot f_{yk}$

Injection system

RAMSET Chemset™ 801 Xtrem™ / RAMSET Chemset™ 800 Xtrem™

Product description

Specification rebar

Annex A2

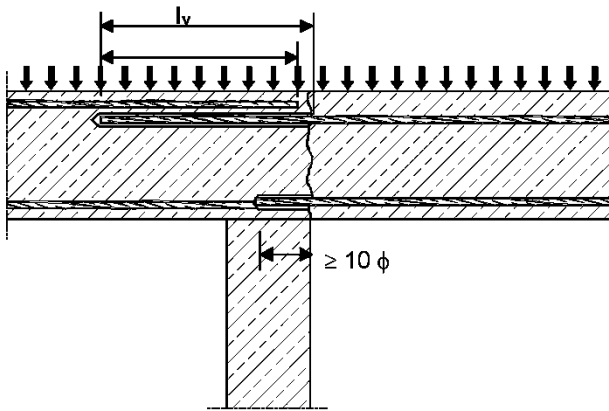

Figure A2: Overlap joint for rebar connections of slabs and beams

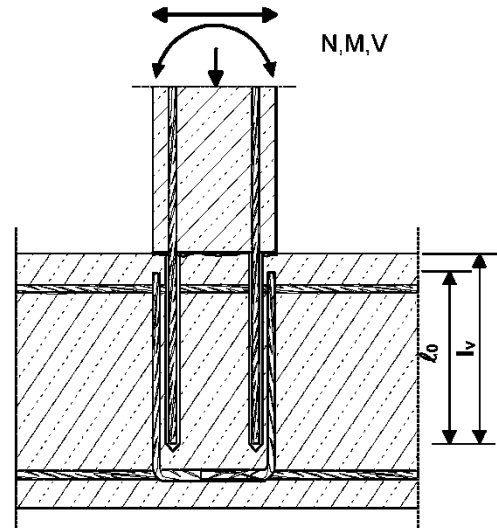

Figure A3: Overlap joint at a foundation of a column or wall where the rebar is stressed in tension

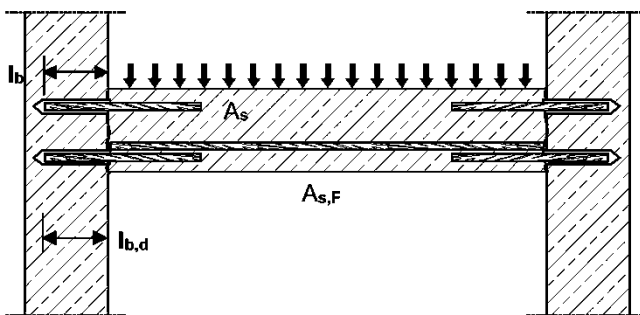

Figure A4: End anchoring of slabs or beams, designed as simply supported

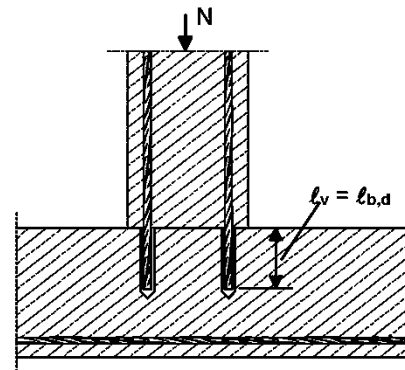

Figure A5: Rebar connection for components stressed primarily in compression. The rebar is stressed in compression

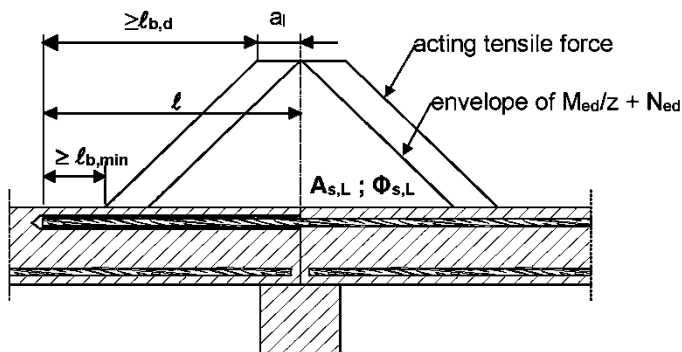

Figure A6: Anchoring of reinforcement to cover the line of acting tensile force

Note to Figure A2 to A6:

- In the Figures no transverse reinforcement is plotted, the transverse reinforcement as required by EN 1992-1-1:2011 shall be present.
- Preparing of joints according to Annex B3

Injection system

RAMSET Chemset™ 801 Xtrem™ / RAMSET Chemset™ 800 Xtrem™

Product description

Installation conditions and application examples reinforcing bar

Annex A3

Cartridges

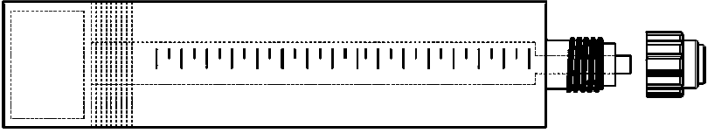
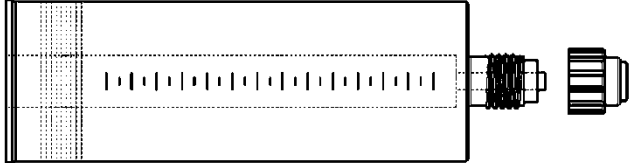
| | |
|---------------------------|--|
| 380 ml coaxiale cartridge |  |
| 750 ml coaxiale cartridge |  |

Injection accessories for deep hole

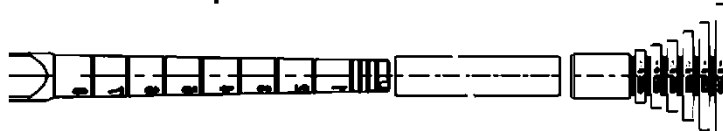

Plastic extension must be use for hole deeper $h_0 > 250$ mm

Piston plug for hole deeper must be use for hole deeper $h_0 > 350$ mm

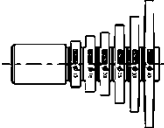
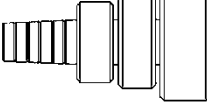
| Cartridge volume | Mixing Nozzle | Extension for piston plug | Piston plug |
|------------------|---|---------------------------|--|
| All cartridges | ISNE mixing nozzle ISNP missing nozzle | Ø13x1000 |  |
| Cartridge 750 ml | High flow mixing nozzle | Ø20x1000 |  |

Injection system

RAMSET Chemset™ 801 Xtrem™ / RAMSET Chemset™ 800 Xtrem™

Product description

Cartridges

Injection accessories for deep hole

Annex A4

Specifications of intended use

Anchorage subject to:

- Static and quasi static loading : rebar size $\phi 8$ to $\phi 32$
- Seismic loading : rebar size $\phi 12$ to $\phi 32$, only hammer drilling and compressed air drilling technique
- Fire exposure : : rebar size $\phi 8$ to $\phi 32$

Base material:

- Compacted Reinforced or unreinforced normal weight concrete without fibres of strength classes C 12/15 to C50/60 according to EN 206:2013+A1:2016
- Maximum chloride content of 0,40 % (CL 0.40) related to the cement content according to EN 206:2013+A1:2016
- Non-carbonated concrete

Note: In case of a carbonated surface of the existing concrete structure the carbonated layer shall be removed in the area of the post-installed rebar connection with a diameter of $\phi + 60$ mm prior to the installation of the new rebar. The depth of concrete to be removed shall correspond to at least the minimum concrete cover in accordance with EN 1992-1-1:2011. The foregoing may be neglected if building components are new and not carbonated and if building components are in dry conditions.

Temperature range:

- **At installation**
-10°C to °40°C
- **In-service**
- 40°C to +80°C: max short term temperature +80°C, max long term temperature +50°C

Design:

- Anchorages are designed under the responsibility of an engineer experienced in anchorages and concrete work.
- Verifiable calculation notes and drawings are prepared taking account of the forces to be transmitted.
- Design under static or quasi-static loading in accordance with EN 1992-1-1:2011 and Annex B3 and under seismic action in accordance with EN 1998-1:2004+AC:2009.
- Design under fire exposure in accordance with EN 1992-1-2:2011
- The actual position of the reinforcement in the existing structure shall be determined on the basis of the construction documentation and taken into account when designing.

Injection system

RAMSET Chemset™ 801 Xtrem™ / RAMSET Chemset™ 800 Xtrem™

Intended used
Specifications

Annex B1

Installation:

▪ **Drilling technique:**

- Hammer drilling technique: all sizes
- Hammer drilling with hollow drill bit XTD: sizes ϕ 12-25
- Compressed air drilling: all sizes
- Diamond drilling technique with roughening tool: sizes ϕ 12-32

▪ **Use category:**

- Dry or wet concrete (not in flooded holes) for Hammer drilling technique, compressed air drilling and diamond drilling technique with roughening tool
 - Only dry concrete for hammer drilling with hollow drill bit XTD
 - Installation direction downwards, horizontal and overhead
- The installation of post-installed rebar resp. tension anchors shall be done only by suitable trained installer and under supervision on site; the conditions under which an installer may be considered as suitable trained and the conditions for supervision on site are up to the Member States in which the installation is done.
- Check the position of the existing rebars (if the position of existing rebars is not known, it shall be determined using a rebar detector suitable for this purpose as well as on the basis of the construction documentation and then marked on the building component for the overlap joint).

| | |
|--|-----------------|
| Injection system RAMSET Chemset™ 801 Xtrem™ / RAMSET Chemset™ 800 Xtrem™ | Annex B2 |
| Intended used Specifications | |

Figure B1: Construction rules for post-installed rebars

- Only tension forces in the axis of the rebar may be transmitted.
- The transfer of shear forces between new concrete and existing structure shall be designed additionally according to EN 1992-1-1:2011.
- The joints for concreting must be roughened to at least such an extent that aggregate protrude.

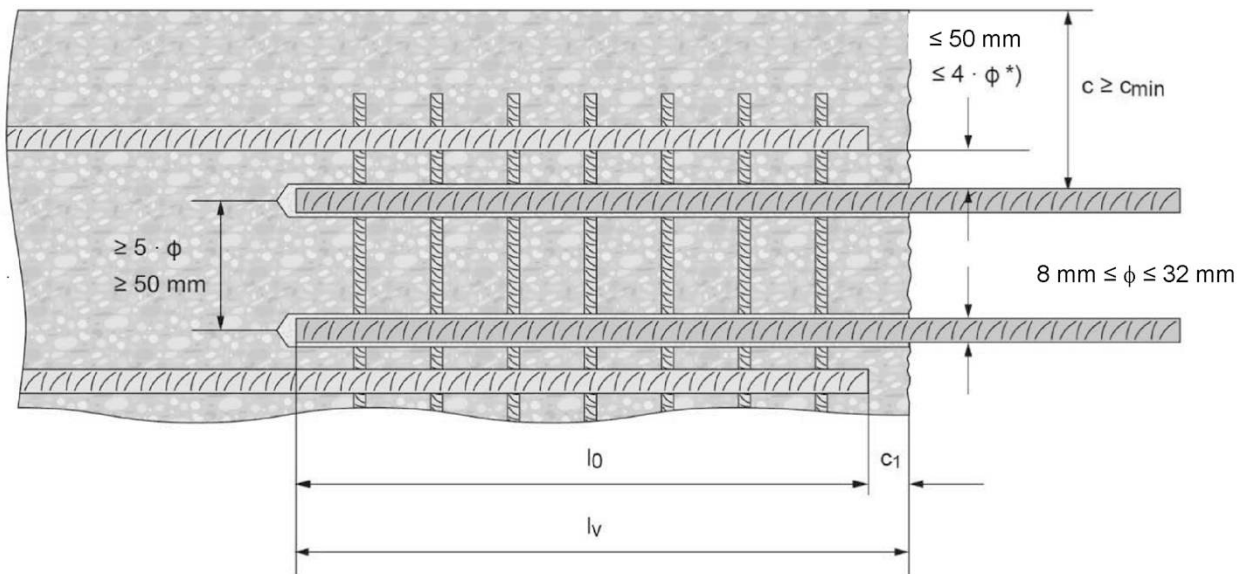

*) If the clear distance between lapped bars exceeds 4ϕ or 50 mm, then the lap length shall be increased by the difference between the clear bar distance and 4ϕ or 50 mm.

- c : concrete cover of post-installed rebar
- c_1 : concrete cover at end-face of existing rebar
- c_{min} : minimum concrete cover according to Table B1, $c_{min,seis}$ according to Table B2 (Annex B4) and to EN 1992-1-1:2011, Section 4.4.1.2
- ϕ : diameter of post-installed rebar
- l_0 : lap length, according to EN 1992-1-1:2011, Section 8.7.3 for static loading and according to EN 1998-1:2004+AC:2009, Section 5.6.3 for seismic action
- l_v : effective embedment depth $\geq l_0 + c_1$
- d_0 nominal drill bit diameter, see Table B5 (Annex B3)
- Minimum spacing between two post-installed bars $a = 50 \text{ mm} \geq 5\phi$

Injection system

RAMSET Chemset™ 801 Xtrem™ / RAMSET Chemset™ 800 Xtrem™

Intended used

General construction rules for post-installed rebars

Annex B3

Table B1: Minimum concrete cover $c_{min}^{1)}$ of post-installed rebar under static loading

| Drilling method | Bar diameter ϕ | Without drilling aid | With drilling aid |
|---|---------------------|-------------------------------------|----------------------------|
| Hammer drilling | < 25 mm | $30 + 0,06 l_v \geq 2\phi$ | $30 + 0,02 l_v \geq 2\phi$ |
| | ≥ 25 mm | $40 + 0,06 l_v \geq 2\phi$ | $40 + 0,02 l_v \geq 2\phi$ |
| Hammer drilling with hollow drill bit XTD | < 25 mm | $30 + 0,06 l_v \geq 2\phi$ | $30 + 0,02 l_v \geq 2\phi$ |
| | ≥ 25 mm | $40 + 0,06 l_v \geq 2\phi$ | $40 + 0,02 l_v \geq 2\phi$ |
| Compressed air drilling | < 25 mm | $50 + 0,08 l_v \geq 2\phi$ | $50 + 0,02 l_v \geq 2\phi$ |
| | ≥ 25 mm | $60 + 0,08 l_v \geq 2\phi$ | $60 + 0,02 l_v \geq 2\phi$ |
| Diamond core drilling | < 25 mm | Drill stand is used as drilling aid | $30 + 0,02 l_v \geq 2\phi$ |
| | ≥ 25 mm | | $40 + 0,02 l_v \geq 2\phi$ |

1) See Annex B3, Figure B1

Note: The minimum concrete cover as specified in EN 1992-1-1:2011 must be observed.

Table B2: Minimum concrete cover $c_{min,seis}$ of post-installed rebar under seismic loading

| Drilling method | Design condition | Distance of 1 st edge | Distance of 2 nd edge |
|---|------------------|----------------------------------|----------------------------------|
| Hammer drilling and Compressed air drilling | Edge | $\geq 4 \phi$ | $\geq 8 \phi$ |
| | Corner | $\geq 6 \phi$ | $\geq 6 \phi$ |

Figure B2: Drilling aid system

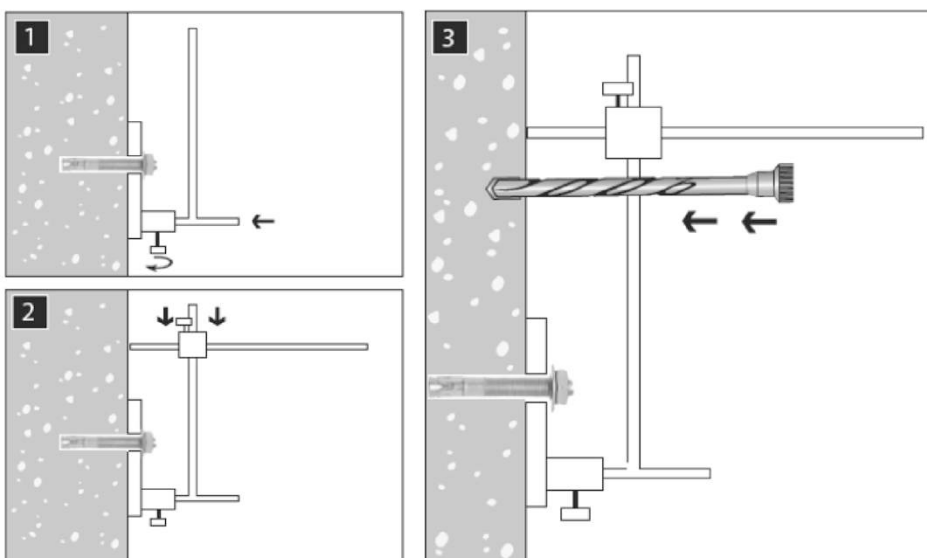

Injection system

RAMSET Chemset™ 801 Xtrem™ / RAMSET Chemset™ 800 Xtrem™

Intended used

Minimum concrete cover

Annex B4

Table B3: Maximum embedment depth $l_{v,max}$ depending on bar diameter and dispenser

| Rebar diameter ϕ [mm] | Maximum embedment length $l_{v,max}$ [mm] | | |
|-------------------------------|--|---------------------|--------|
| | Manuel Dispenser | Pneumatic Dispenser | |
| | 380 ml 750 ml | 380 ml | 750 ml |
| 8 | 500 | 600 | 900 |
| 10 | | | |
| 12 | | | |
| 16 | | | |
| 20 | | | |
| 25 | | | |
| 28 | | | |
| 32 | | | |

Table B4: Installation parameters

| Rebar diameter ϕ [mm] | Nominal drilling diameter d_{cut} [mm] | | | |
|-------------------------------|---|--|-----------------|--|
| | Hammer drilling | Hammer drilling with hollow drill bit XTD ¹⁾ | Diamond core | Diamond core and roughening drill bit |
| 8 | 10 | - | - | - |
| 10 | 12 | - | - | - |
| 12 | 15 | 16 | 16 | - |
| 16 | 20 | 20 | - | 20 |
| 20 | 25 | 25 | - | 25 |
| 25 | 30 | 30 | - | 30 |
| 28 | 35 | - | - | 35 |
| 32 | 40 | - | - | 40 |

¹⁾ Maximum working length: 600 mm

Injection system
RAMSET Chemset™ 801 Xtrem™ / RAMSET Chemset™ 800 Xtrem™

Intended used
Maximum embedment depth $l_{v,max}$
Installation parameters

Annex B5

Table B5: Parameters for use of Roughening tool

| Diamond coring d_{cut} [mm] | Roughening tool ¹⁾ d_{cut} [mm] |
|----------------------------------|---|
| 20 | 20 |
| 25 | 25 |
| 30 | 30 |
| 35 | 35 |
| 40 | 40 |

¹⁾ For checking the wear of roughening drill bit, a wear gauge is delivered with each roughening tool

Table B6: Dimensions of the cleaning tools for reinforcing bars (rebars)

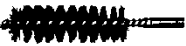
| Dimensions | Nominal diameter of the reinforcing bars (rebars) | | | | | | | | |
|---|---|-----------|-----------|-----------|-----------|-----------|-----------|-----------|-----------|
| | $\phi 8$ | $\phi 10$ | $\phi 12$ | $\phi 14$ | $\phi 16$ | $\phi 20$ | $\phi 25$ | $\phi 28$ | $\phi 32$ |
| \emptyset Brush [mm] ¹⁾  | 11 | 13 | 16 | 20 | 22 | 26 | 32 | 37 | 42 |
| \emptyset Plastic extension for compress air | 6 | 9 | 9 | 13 | 13 | 13 | 13/20 | 13/20 | 13/20 |

¹⁾ The diameter of the round steel brush shall be checked before use. The minimum brush diameter has to be at least equal to the borehole diameter d_0 . The round steel brush shall produce natural resistance as it enters the drill hole. If this is not the case, please use a new brush or a brush with a larger diameter.

| | |
|---|----------|
| Injection system RAMSET Chemset™ 801 Xtrem™ / RAMSET Chemset™ 800 Xtrem™ | Annex B6 |
| Intended used Parameters for using of roughening drill bit Dimensions of cleaning tools | |

Table B7: Gel time and curing time for Regular Version

| Temperature of base material | Working time | Curing time ¹⁾ |
|------------------------------|--------------|---------------------------|
| -10°C to -5°C | 90 min | 24 h |
| -4°C to 0°C | 50 min | 240 min |
| 1°C to 5°C | 25 min | 120 min |
| 6°C to 10°C | 15 min | 90 min |
| 11°C to 20°C | 7 min | 60 min |
| 21°C to 30°C | 4 min | 45 min |
| 31°C to 40°C | 2 min | 30 min |

¹⁾ For wet concrete the curing time must be doubled

Table B8: Gel time and curing time for Tropical Version:

| Temperature of base material | Working time | Curing time ¹⁾ |
|------------------------------|--------------|---------------------------|
| + 5°C | 60 min | 240 min |
| 6°C to 10°C | 40 min | 180 min |
| 11°C to 20°C | 15 min | 120 min |
| 21°C to 30°C | 8 min | 60 min |
| 31°C to 40°C | 4 min | 60 min |

¹⁾ For wet concrete the curing time must be doubled

Injection system



RAMSET Chemset™ 801 Xtrem™ / RAMSET Chemset™ 800 Xtrem™

Product description

Minimum curing time and maximum working time

Annex B7

Drilling the hole:

| | |
|---|--|
|  | Rotary hammer drilling or compressed air drilling |
|  | Electrical hammer drilling with XTD hollow drill bit used in relation with the RAMSET vacuum or the type. This drilling technique allows for cleaning the hole from the dust debris while operating drilling. No further cleaning is then required before injecting resin. |
|  | Diamond core drilling The roughening tool must be used for core diameter higher than 20 mm. |

Cleaning the hole:

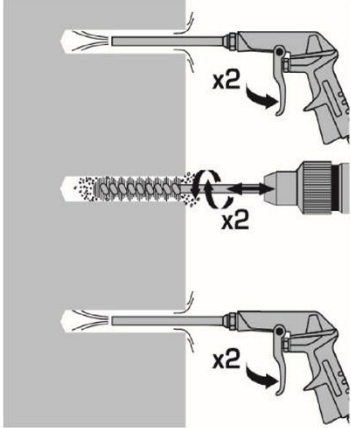
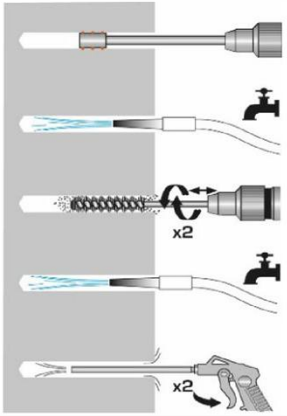
| Hammer drilling technique | |
|--|---|
|  | <ol style="list-style-type: none"> 1. Using compress air cleaning (min 6 bars), use the appropriate extension, starting from the top of the hole blow out at least 2 times by moving downward to the bottom of the hole then moving upward to the top of the hole and until no dust is evacuated. (not less than 10s per each blowing). 2. Using the relevant brush and extension fitted on a RAMSET drilling machine, starting from the top of the hole, move downward to the bottom of the hole then move upward to the top of the hole. Repeat this operation. 3. Using compress air cleaning (min 6 bars), use the appropriate extension, starting from the top of the hole blow out at least 2 times by moving downward to the bottom of the hole then moving upward to the top of the hole and until no dust is evacuated. (not less than 10s per each blowing). |
| Hammer drilling technique | |
| Electrical hammer drilling with XTD hollow drill bit used in relation with the RAMSET vacuum or the type. This drilling technique allows for cleaning the hole from the dust debris while operating drilling. No further cleaning is then required before injecting resin. | |
| Diamond core drilling technique | |
|  | <ol style="list-style-type: none"> 1. For core diameter higher than 20 mm, remove water in the hole and use the roughening drill bit before applying cleaning procedure 2. Clean the hole with tap water. 3. Using the relevant brush and extension fitted on a RAMSET drilling machine, starting from the top of the hole, move downward to the bottom of the hole then move upward to the top of the hole. Repeat this operation. 4. Clean the hole with tap water 5. Using compress air cleaning (mini 6 bars), use the appropriate extension, starting from the top of the hole blow out at least 2 times by moving downward to the bottom of the hole then moving upward to the top of the hole and until no dust is evacuated. (not less than 10s per each blowing). |

Injection system

RAMSET Chemset™ 801 Xtrem™ / RAMSET Chemset™ 800 Xtrem™

Product description

Installation instruction

Annex B8

Safety precaution:

The safety data sheet must be read before using the product and the safety instructions followed.

- Storage temperature of cartridge +0°C à +35 °C
- Cartridge temperature at time of installation: Must be $\geq +5^{\circ}\text{C}$
- Base material temperature at time of installation: Must be between -10°C and $+40^{\circ}\text{C}$
- Check the date of expiry of the cartridge

Dispensing into the hole:

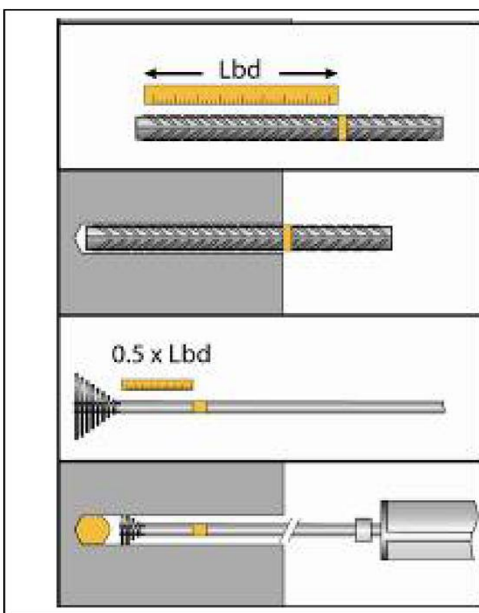

1. Put the anchorage depth mark on the rebar
2. Check the anchorage depth
3. Cut the piston plug at the relevant diameter. The volume of resin that need to be injected in the hole must be indicated on the mixing nozzle or its extension. The marking must be placed at 0.5 time the anchorage depth
4. Dispense the first part to waste until an even colour is achieved ($\approx 20\text{cm}$). Insert the nozzle to the far end of the hole, and inject the resin, withdrawing the nozzle as the hole fills in order to avoid trapping air bubbles. Fill the hole until the mark appear. For pneumatic dispenser with 380 ml cartridge, the maximum pressure is 6 bars.

Inserting the rebar:

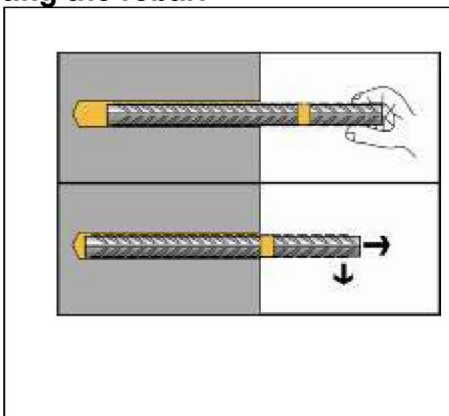

1. Immediately insert the rebar, slowly and with a slight twisting motion. Remove excess resin from around the mouth of the hole before it sets. Control the embedment depth during the working time (See Annex B7 Table B7 or B8) which varies according to temperature of base material.
2. Leave the rebar undisturbed until the curing time has elapsed. (See Annex B7 Table B7 or B8)

Injection system

RAMSET Chemset™ 801 Xtrem™ / RAMSET Chemset™ 800 Xtrem™

Product description

Installation instruction

Annex B9

Minimum anchorage length and minimum lap length

The minimum anchorage length $l_{b,min}$ and the minimum lap length $l_{0,min}$ according to EN 1992-1-1:2011 shall be multiplied by the relevant amplification factor $\alpha_{lb} = \alpha_{lb,100y}$ given in Table C1.

Table C1: Amplification factor $\alpha_{lb} = \alpha_{lb,100y}$ related to concrete strength class for Hammer drilling and compressed air drilling with a working life of 50 or 100 years under static loading

| Bar diameter | Amplification factor $\alpha_{lb} = \alpha_{lb,100y}$ [-] | | | | | | | | |
|--------------|---|--------|--------|--------|--------|--------|--------|--------|--------|
| | Concrete strength class | | | | | | | | |
| | C12/15 | C16/20 | C20/25 | C25/30 | C30/37 | C35/45 | C40/50 | C45/55 | C50/60 |
| φ8 | 1,0 | | | | | | | | |
| φ10 | 1,0 | | | | | | | | |
| φ12 | 1,0 | | | | | | | | |
| φ14 | 1,0 | | | | | | | 1,1 | |
| φ16 | 1,0 | | | | | | 1,1 | | |
| φ20 | 1,0 | | | | | | 1,1 | 1,2 | 1,2 |
| φ25 | 1,0 | | | 1,1 | | | 1,2 | 1,3 | 1,3 |
| φ28 | 1,0 | | | 1,1 | | | 1,2 | 1,3 | 1,4 |
| φ32 | 1,0 | | | 1,2 | | | 1,3 | 1,4 | 1,5 |

Table C2: Bond efficiency factor $k_b = k_{b,100y}$ for Hammer drilling and compressed air drilling with a working life of 50 or 100 years under static loading

| Bar diameter | Bond efficiency factor $k_b = k_{b,100y}$ [-] | | | | | | | | |
|--------------|---|--------|--------|--------|--------|--------|--------|--------|--------|
| | Concrete strength class | | | | | | | | |
| | C12/15 | C16/20 | C20/25 | C25/30 | C30/37 | C35/45 | C40/50 | C45/55 | C50/60 |
| φ8-φ32 | 1,0 | 1,0 | 1,0 | 1,0 | 1,0 | 1,0 | 1,0 | 1,0 | 1,0 |

Table C3: Design values of the bond resistance $f_{bd,PIR} = f_{bd,PIR,100y}$ in N/mm² for Hammer drilling and compressed air drilling with a working life of 50 or 100 years under static loading

$$f_{bd,PIR} = k_b \cdot f_{bd}$$

$$f_{bd,PIR,100y} = k_{b,100y} \cdot f_{bd}$$

f_{bd} : Design value of the bond strength in N/mm² considering the concrete strength classes and the rebar diameter for good bond condition (for all other bond conditions multiply the values by $\eta_1 = 0,7$) and recommended partial factor $\gamma_c = 1,5$ according to EN 1992-1-1:2011

k_b and $k_{b,100y}$: Bond efficiency factor according to Table C2

| Bar diameter | Bond resistance $f_{bd,PIR} = f_{bd,PIR,100y}$ [N/mm ²] | | | | | | | | |
|--------------|---|--------|--------|--------|--------|--------|--------|--------|--------|
| | Concrete strength class | | | | | | | | |
| | C12/15 | C16/20 | C20/25 | C25/30 | C30/37 | C35/45 | C40/50 | C45/55 | C50/60 |
| φ8-φ32 | 1,6 | 2,0 | 2,3 | 2,7 | 3,0 | 3,4 | 3,7 | 4,0 | 4,3 |

Injection system

RAMSET Chemset™ 801 Xtrem™ / RAMSET Chemset™ 800 Xtrem™

Performance

Minimum anchor length and minimum lap length, amplification factor, bond efficiency factor and design value of bond strength under static loading

Annex C1

Minimum anchorage length and minimum lap length

The minimum anchorage length $l_{b,min}$ and the minimum lap length $l_{0,min}$ according to EN 1992-1-1:2011 shall be multiplied by the relevant amplification factor α_{lb} given in Table C4.

Table C4: Amplification factor α_{lb} for Hammer drilling with XTD hollow drill bit with a working life of 50 years under static loading

| Bar diameter | Amplification factor α_{lb} [-] | | | | | | | | |
|-------------------|--|--------|--------|--------|--------|--------|--------|--------|--------|
| | Concrete strength class | | | | | | | | |
| | C12/15 | C16/20 | C20/25 | C25/30 | C30/37 | C35/45 | C40/50 | C45/55 | C50/60 |
| $\phi 12-\phi 25$ | 1,5 | | | | | | | | |

Table C5: Bond efficiency value k_b for Hammer drilling with XTD hollow drill bit with a working life of 50 years under static loading

| Bar diameter | Bond efficiency factor k_b [-] | | | | | | | | |
|-------------------|----------------------------------|--------|--------|--------|--------|--------|--------|--------|--------|
| | Concrete strength class | | | | | | | | |
| | C12/15 | C16/20 | C20/25 | C25/30 | C30/37 | C35/45 | C40/50 | C45/55 | C50/60 |
| $\phi 12-\phi 25$ | 1,0 | | | | | | | | |

Table C6: Design values of the ultimate bond stress $f_{bd,PIR}$ in N/mm² for Hammer drilling with XTD hollow drill bit with a working life of 50 years under static loading

$$f_{bd,PIR} = k_b \cdot f_{bd}$$

f_{bd} : Design value of the bond strength in N/mm² considering the concrete strength classes and the rebar diameter for good bond condition (for all other bond conditions multiply the values by $\eta_1 = 0,7$) and recommended partial factor $\gamma_c = 1,5$ according to EN 1992-1-1:2011

k_b : Bond efficiency factor according to Table C5

| Bar diameter | Bond resistance $f_{bd,PIR}$ [N/mm ²] | | | | | | | | |
|-------------------|---|--------|--------|--------|--------|--------|--------|--------|--------|
| | Concrete strength class | | | | | | | | |
| | C12/15 | C16/20 | C20/25 | C25/30 | C30/37 | C35/45 | C40/50 | C45/55 | C50/60 |
| $\phi 12-\phi 25$ | 1,6 | 2,0 | 2,3 | 2,7 | 3,0 | 3,4 | 3,7 | 4,0 | 4,3 |

Injection system

RAMSET Chemset™ 801 Xtrem™ / RAMSET Chemset™ 800 Xtrem™

Performance

Minimum anchor length and minimum lap length, amplification factor, bond efficiency factor and design value of bond strength under static loading

Annex C2

Minimum anchorage length and minimum lap length

The minimum anchorage length $l_{b,min}$ and the minimum lap length $l_{0,min}$ according to EN 1992-1-1:2011 shall be multiplied by the relevant amplification factor α_{lb} given in Table C7.

Table C7: Amplification factor α_{lb} for Diamond drilling with a working life of 50 years under static loading

| Bar diameter | Amplification factor α_{lb} [-] | | | | | | | | |
|--------------|--|--------|--------|--------|--------|--------|--------|--------|--------|
| | Concrete strength class | | | | | | | | |
| | C12/15 | C16/20 | C20/25 | C25/30 | C30/37 | C35/45 | C40/50 | C45/55 | C50/60 |
| $\phi 12$ | 1,0 | | | | | | | 1,1 | 1,2 |
| $\phi 14$ | | | | | | | | | |
| $\phi 16$ | | | | | | | | | |
| $\phi 20$ | | | | | | | | 1,1 | |
| $\phi 25$ | | | | | | | | | |
| $\phi 28$ | | | | | | | | 1,0 | |
| $\phi 32$ | 1,0 | | | | | | | | |

Table C8: Bond efficiency value k_b for Diamond drilling with a working life of 50 years under static loading

| Bar diameter | Bond efficiency factor k_b [-] | | | | | | | | |
|-------------------|----------------------------------|--------|--------|--------|--------|--------|--------|--------|--------|
| | Concrete strength class | | | | | | | | |
| | C12/15 | C16/20 | C20/25 | C25/30 | C30/37 | C35/45 | C40/50 | C45/55 | C50/60 |
| $\phi 12-\phi 20$ | 1,0 | | | | | | | | |
| $\phi 25$ | 1,0 | | | | | | | 0,9 | |
| $\phi 28$ | 1,0 | | | | | | 0,9 | 0,9 | |
| $\phi 32$ | 1,0 | | | | | 0,9 | 0,8 | 0,9 | |

Table C9: Design values of the ultimate bond stress $f_{bd,PIR}$ in N/mm² for Diamond drilling with a working life of 50 years under static loading

$$f_{bd,PIR} = k_b \cdot f_{bd}$$

f_{bd} : Design value of the bond strength in N/mm² considering the concrete strength classes and the rebar diameter for good bond condition (for all other bond conditions multiply the values by $\eta_1 = 0,7$) and recommended partial factor $\gamma_c = 1,5$ according to EN 1992-1-1:2011

k_b : Bond efficiency factor according to Table C8.

| Bar diameter | Bond resistance $f_{bd,PIR}$ [N/mm ²] | | | | | | | | | |
|-------------------|---|--------|--------|--------|--------|--------|--------|--------|--------|-----|
| | Concrete strength class | | | | | | | | | |
| | C12/15 | C16/20 | C20/25 | C25/30 | C30/37 | C35/45 | C40/50 | C45/55 | C50/60 | |
| $\phi 12-\phi 20$ | 1,6 | | | | | | | 3,7 | 4,0 | 4,3 |
| $\phi 25$ | | | | | | | | | | 4,0 |
| $\phi 28$ | | | | | | | | 3,7 | 4,0 | |
| $\phi 32$ | | | | | | | | 3,4 | 3,4 | 3,7 |

Injection system

RAMSET Chemset™ 801 Xtrem™ / RAMSET Chemset™ 800 Xtrem™

Performance

Minimum anchor length and minimum lap length, amplification factor, bond efficiency factor and design value of bond strength under static loading

Annex C3

Minimum anchorage length and minimum lap length

The minimum anchorage length $l_{b,min}$ and the minimum lap length $l_{0,min}$ according to EN 1992-1-1:2011 shall be multiplied by the relevant amplification factor $\alpha_{lb,seis} = \alpha_{lb,seis,100y}$ given in Table C10.

Table C10: Amplification factor $\alpha_{lb,seis} = \alpha_{lb,seis,100y}$ for Hammer drilling and compressed air drilling with a working life of 50 or 100 years under seismic loading

| Bar diameter | Amplification factor $\alpha_{lb,seis} = \alpha_{lb,seis,100y}$ [-] | | | | | | | |
|--------------|---|--------|--------|--------|--------|--------|--------|--------|
| | Concrete strength class | | | | | | | |
| | C16/20 | C20/25 | C25/30 | C30/37 | C35/45 | C40/50 | C45/55 | C50/60 |
| $\phi 12$ | 1,0 | | | | | | | |
| $\phi 14$ | 1,0 | | | | | | 1,1 | |
| $\phi 16$ | 1,0 | | | | 1,1 | | | |
| $\phi 20$ | 1,0 | | | 1,1 | | 1,2 | 1,2 | |
| $\phi 25$ | 1,0 | | 1,1 | | 1,2 | 1,3 | 1,3 | |
| $\phi 28$ | 1,0 | | 1,1 | | 1,2 | 1,3 | 1,4 | |
| $\phi 32$ | 1,0 | | 1,2 | | 1,3 | 1,4 | 1,5 | |

Table C10: Bond efficiency factor $k_{b,seis} = k_{b,seis,100y}$ for Hammer drilling and compressed air drilling with a working life of 50 or 100 years under seismic loading

| Bar diameter | Bond efficiency factor $k_{b,seis} = k_{b,seis,100y}$ [-] | | | | | | | |
|-------------------|---|--------|--------|--------|--------|--------|--------|--------|
| | Concrete strength class | | | | | | | |
| | C16/20 | C20/25 | C25/30 | C30/37 | C35/45 | C40/50 | C45/55 | C50/60 |
| $\phi 12-\phi 20$ | 1,0 | 1,0 | 1,0 | 1,0 | 1,0 | 1,0 | 1,0 | 1,0 |
| $\phi 25$ | | | | | 0,92 | 0,93 | 0,92 | 0,93 |
| $\phi 28$ | | | | | 0,90 | 0,82 | 0,76 | 0,79 |
| $\phi 32$ | | | | | 0,86 | 0,76 | 0,69 | 0,63 |

Table C11: Design values of the bond resistance $f_{bd,PIR,seis} = f_{bd,PIR,seis,100y}$ in N/mm² for Hammer drilling and compressed air drilling with a working life of 50 or 100 years under seismic loading

$$f_{bd,PIR,seis} = k_{b,seis} \cdot f_{bd}$$

$$f_{bd,PIR,seis,100y} = k_{b,seis,100y} \cdot f_{bd}$$

f_{bd} : Design value of the bond strength in N/mm² considering the concrete strength classes and the rebar diameter for good bond condition (for all other bond conditions multiply the values by $\eta_1 = 0,7$) and recommended partial factor $\gamma_c = 1,5$ according to EN 1992-1-1:2011

$k_{b,seis}$ and $k_{b,seis,100y}$: Bond efficiency factor according to Table C10

| Bar diameter | Bond resistance $f_{bd,PIR,seis} = f_{bd,PIR,seis,100y}$ [N/mm ²] | | | | | | | |
|-------------------|---|--------|--------|--------|--------|--------|--------|--------|
| | Concrete strength class | | | | | | | |
| | C16/20 | C20/25 | C25/30 | C30/37 | C35/45 | C40/50 | C45/55 | C50/60 |
| $\phi 12-\phi 20$ | 2,0 | 2,3 | 2,7 | 3,0 | 3,4 | 3,7 | 4,0 | 4,3 |
| $\phi 25$ | | | | | 3,7 | 4,0 | 3,7 | 4,0 |
| $\phi 28$ | | | | | 3,0 | 3,0 | 3,0 | 3,4 |
| $\phi 32$ | | | | | 2,3 | 2,3 | 2,3 | 2,3 |

Injection system

RAMSET Chemset™ 801 Xtrem™ / RAMSET Chemset™ 800 Xtrem™

Performance

Minimum anchor length and minimum lap length, amplification factor, bond efficiency factor and design value of bond strength under seismic loading

Annex C4

Design value of ultimate bond strength in case of fire $f_{bd,fi}$, $f_{bd,fi,100y}$ [N/mm²] at increased temperature for concrete strength classes C12/15 to C50/60, all drilling methods and a working life of 50 or 100 years

The design value of bond strength under fire exposure $f_{bd,fi}$, $f_{bd,fi,100y}$ at increased temperature has to be calculated by the following equation:

$$f_{bd,fi,(100y)} = k_{b,fi,(100y)}(\theta) \cdot f_{bd,PIR,(100y)} \cdot \gamma_c / \gamma_{M,fi}$$

where

$$\theta < 281 \text{ °C: } k_{b,fi,(100y)}(\theta) = \min \{1,0; 23,755 e^{-0,011 \cdot \theta} / (f_{bd,PIR,(100y)} \cdot 4,3)\}$$

$$\theta > 281 \text{ °C: } k_{b,fi,(100y)} = 0$$

- $f_{bd,fi}$ Design value of ultimate bond strength at increased temperature in N/mm² for working life 50 years
- $f_{bd,fi,100y}$ Design value of ultimate bond strength at increased temperature in N/mm² for working life 100 years
- θ Temperature in °C in the mortar layer
- $k_{b,fi}(\theta)$ Reduction factor at increased temperature for working life 50 years
- $k_{b,fi,100y}(\theta)$ Reduction factor at increased temperature for working life 100 years
- $f_{bd,PIR}$ Design values of the ultimate bond strength in N/mm² in cold condition according to Table C3, C6 or C9 considering the concrete strength class, rebar diameter, drilling method and bond condition according to EN 1992-1-1:2011
- $f_{bd,PIR,100y}$ Design values of the ultimate bond strength in N/mm² in cold condition according to Table C3 considering the concrete strength class, rebar diameter, drilling method and bond condition according to EN 1992-1-1:2011.
- γ_c = 1,5 recommended partial factor according to EN 1992-1-1:2011
- $\gamma_{M,fi}$ = 1,0 recommended partial factor according to EN 1992-1-2:2011

For evidence a increased Temperature the anchorage length shall be calculated according to EN 1992-1-1:2011, Equation 8.3 using the temperature-dependent design value of ultimate bond strength $f_{bd,fi}$, $f_{bd,fi,100y}$.

Figure C1: Example graph of reduction factor $k_{b,fi(100y)}(\theta)$ for concrete strength class C20/25 for good bond conditions

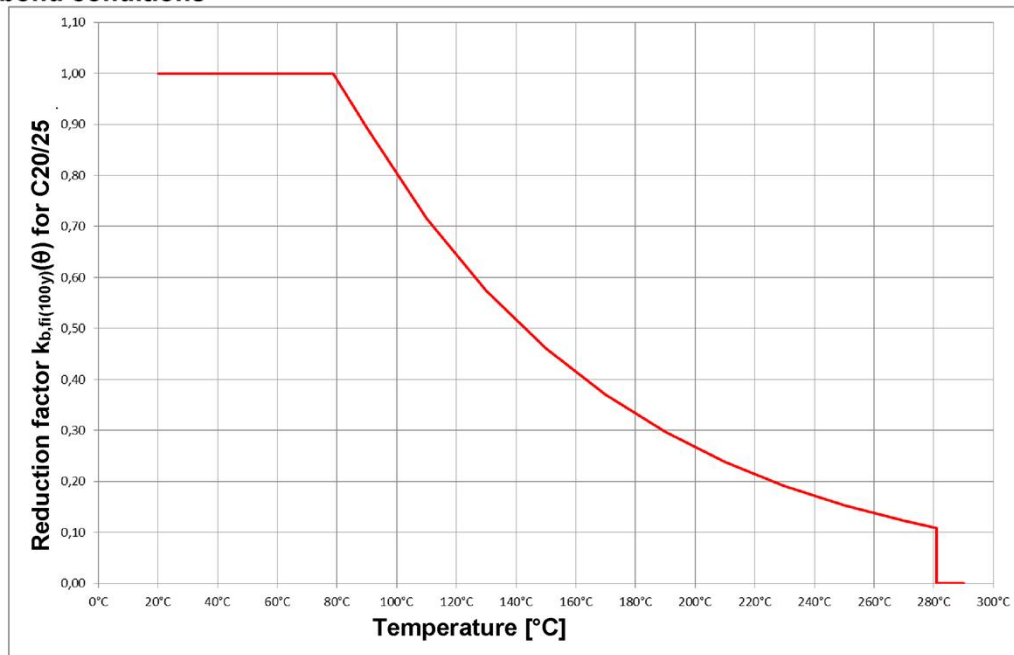

Injection system

RAMSET Chemset™ 801 Xtrem™ / RAMSET Chemset™ 800 Xtrem™

Annex C5

Performance

Design value of bond strength $f_{bd,fi}$, $f_{bd,fi,100y}$ at increased temperature