

SPECIFIERS **ANCHORING** **RESOURCE BOOK** **ANZ Edition 3**



View our
products
online fast.

For more information on our products go to
ramset.com.au or call 1300 780 063
www.ramset.co.nz or call 0800 RAMSET (726738)

iEXPERT

Innovative Construction Solutions Anchor Design Software

- Fast & simple anchor design
- Australian, New Zealand, European and US design Methods
- Cracked concrete, fire and seismic design
- Animated Design Load Actions and 3D Output



Available on the Ramset™ AUS and NZ websites as both an online option accessed via web browser or an offline version via download.



Welcome To The Ramset™ Specifiers Resource Book

The Ramset™ Specifiers Resource Book contains information most useful to Specifiers, Engineers and Architects when selecting the concrete anchoring solution that best suits their project.

Selection of a concrete anchoring product is made on the basis of the basic type of fixing (bolt, stud or internally threaded), macro environment, (e.g. coastal or inland), micro environment (particular chemicals) and of course the capacity that best meets the design load case.

Where the fixing is simple and does not warrant extensive strength limit state calculations, selection on the basis of load case is made simple with summarised load tables for each concrete anchor.

Where more vigorous design and strength limit state calculation is required, the simplified step-by-step method presented in this booklet will allow rapid selection and verification of the appropriate concrete anchor for a variety of load performance requirements.

The Brick and Block anchoring section gives design professionals guidance as to the behaviour of a number of fixings suitable for use in a variety of both solid and hollow pre-manufactured masonry units. The capacity information presented considers the elemental nature of pre-manufactured masonry units and advises designers as to suitable locations within the units accordingly. For additional information or any further enquiries, contact your local Ramset™ engineer:

Australia enquiry@ramset.com.au or call 1300 780 063

New Zealand engineer@ramset.co.nz or call 0800 726738

What's new in the 2022 SARB Edition ?

At Ramset we are committed to ongoing innovation in our engineering resources. As a reflection of our continued product innovation and development, this latest edition includes the following improvements and new products;

- **New Reo502™ Plus - Anchor Stud - Seismic C1- M10 to M30 (100 year working life)**
- **New Reo502™ Plus - Reinforcing Bar - Seismic C1 (100 year working life)**
- **New Reo502™ Plus - Reinforcing Bar to AS3600 & AS5216**
- **New EPCON™ C6 Plus - Reinforcing Bar - Seismic C1 (100 year working life)**
- **New EPCON™ C6 Plus - Anchor Stud - Seismic C1- M10 to M30 (100 year working life)**
- **New EPCON™ C8 Xtrem™ - Reinforcing Bar to AS3600 & AS5216 (100 Year working life)**
- **New EPCON™ C8 Xtrem™ - Reinforcing Bar Development Length - Seismic (100 year working life)**
- **New 801 Xtrem™ XC² - Reinforcing Bar - Seismic C1**
- **New 801 Xtrem™ XC² - Reinforcing Bar to AS3600 & AS5216 (100 Year working life)**
- **New AnkaScrew Xtrem™ - Seismic C1 & C2**
- **New AnkaScrew Xtrem™ - Rod Holder Metal Deck (ComFlor™) - Seismic - ACI 355.2**
- **New AnkaScrew Xtrem™ Metal Deck (ComFlor™) - Seismic - ACI 355.2**
- **New AnkaScrew Xtrem™ - Cracked and Non-cracked**
- **New AnkaScrew Xtrem™ - Fire Rated**
- **New TruBolt™ Xtrem™ Zn/A4 SS - Seismic C1 & C2**
- **New TruBolt™ Xtrem™ Zn/A4 SS - Cracked and Non-cracked**
- **New TruBolt™ Xtrem™ Metal Deck (ComFlor™) - Seismic - ACI 355.2**
- **New TruBolt™ Xtrem™ - Cracked and Non-cracked**

Contents

SPECIFIERS RESOURCE BOOK

INTERACTIVE INDEX
Click on content list to navigate

Contents

INTRODUCTION		
1	LEGEND OF SYMBOLS	5
2	NOTATION	6
3	DESIGN PROCESS	7
4	ANCHOR SELECTION GUIDE	17
5	ANCHOR TECHNOLOGY	22
SEISMIC ANCHORS		
	INTRODUCTION	42
6	SEISMIC STANDARDS FOR ANCHORS	43
7	SEISMIC ANCHOR OVERVIEW	44
8	EPCON™ C8 XTREM™ - SEISMIC ANCHOR STUDS	45
9	EPCON™ C8 XTREM™ - SEISMIC REINFORCING BAR	53
10	EPCON™ C6 PLUS - SEISMIC ANCHOR STUDS	55
11	EPCON™ C6 PLUS - SEISMIC REINFORCING BAR	63
12	CHEMSET™ REO 502™ PLUS - SEISMIC ANCHOR STUDS	71
13	CHEMSET™ REO 502™ PLUS - SEISMIC REINFORCING BAR	79
14	CHEMSET™ 801 XTREM™ XC ² - SEISMIC ANCHOR STUDS	87
15	CHEMSET™ 801 XTREM™ XC ² - SEISMIC XTREM™ ANCHOR STUDS	95
16	CHEMSET™ 801 XTREM™ XC ² - SEISMIC REINFORCING BAR	103
17	SPATEC™ XTREM™ SEISMIC ANCHOR	111
18	TRUBOLT™ XTREM™ SEISMIC ANCHOR	119
19	ANKASCREW™ XTREM™ SEISMIC ANCHOR	127
20	SEISMIC ANCHOR - COMPOSITE FLOORING APPLICATION	136
21	ANKASCREW™ XTREM™ - SEISMIC ANCHOR - COMPOSITE FLOORING	137
22	ANKASCREW™ XTREM™ ROD HOLDER - SEISMIC ANCHOR - COMPOSITE FLOORING	138
23	TRUBOLT™ XTREM™ - SEISMIC ANCHOR - COMPOSITE FLOORING	139
CHEMICAL ANCHORING - ANCHOR STUDS		
	INTRODUCTION & ESTIMATING CHART	140
24	CHEMSET™ ANCHOR STUDS	141
25	CHEMSET™ REO 502™ PLUS INJECTION WITH ANCHOR STUDS	142
26	EPCON™ C8 XTREM™ INJECTION WITH ANCHOR STUDS	150
27	EPCON™ C6 PLUS INJECTION WITH ANCHOR STUDS	158
28	CHEMSET™ 801 XTREM™ XC ² INJECTION WITH ANCHOR STUDS	166
29	CHEMSET™ 101 PLUS INJECTION WITH ANCHOR STUDS	174
30	CHEMSET™ MAXIMA™ SPIN CAPSULES WITH ANCHOR STUDS	182
CHEMICAL ANCHORING - THREADED INSERTS		
	INTRODUCTION	190
31	THREADED INSERTS	191
CHEMICAL ANCHORING - REINFORCING BAR ANCHORAGE		
	INTRODUCTION	198
32	CHEMSET™ REO 502™ PLUS INJECTION WITH REINFORCING BAR	199
33	EPCON™ C8 XTREM™ INJECTION WITH REINFORCING BAR	207
34	EPCON™ C6 PLUS INJECTION WITH REINFORCING BAR	215
35	CHEMSET™ 801 XTREM™ XC ² INJECTION WITH REINFORCING BAR	223
36	CHEMSET™ 101 PLUS INJECTION WITH REINFORCING BAR	231

CHEMICAL ANCHORING - REINFORCING BAR TO AS3600-2018		
	INTRODUCTION	240
37	DESIGN PROCESS FOR AS3600-2018	242
38	GRADE 500 REINFORCING BAR ENGINEERING PROPERTIES	244
39	CHEMSET™ REO502™ PLUS INJECTION INFORMATION	245
40	CHEMSET™ 801 XTREM™ XC ² INJECTION INFORMATION	246
41	EPCON™ C8 XTREM™ INJECTION INFORMATION	247
42	STRENGTH LIMIT STATE DESIGN	248
MECHANICAL ANCHORING		
	INTRODUCTION	256
43	SPATEC™ XTREM™ SAFETY ANCHORS	257
44	BOA™ COIL EXPANSION ANCHORS	265
45	TRUBOLT™ XTREM™ STUD ANCHORS	273
46	TRUBOLT™ STUD ANCHORS	281
47	ANKASCREW™ XTREM™ SCREW IN ANCHORS	289
48	WERCS ANKASCREW™ SCREW IN ANCHORS	297
49	DYNABOLT™ PLUS SLEEVE ANCHORS	305
50	DYNASET™ DROP IN ANCHORS	307
BRICK AND BLOCK ANCHORING		
	INTRODUCTION	310
51	TYPICAL MASONRY UNITS	311
52	CHEMSET™ 101 PLUS INJECTION	314
53	WERCS ANKASCREW™	316
54	DYNABOLT™ PLUS HEX BOLT	318
55	RAMPLUG™ ANCHORS	320
56	TYPICAL BOLT PERFORMANCE INFORMATION	322
FIRE RATED ANCHORING SYSTEMS		
	INTRODUCTION	324
57	SUSPENSION ANCHORS - FIRE RATED	325
58	SPATEC™ XTREM™ SAFETY ANCHORS - FIRE RATED MECH. ANCHOR	326
59	TRUBOLT™ XTREM™ - FIRE RATED MECH. ANCHOR	333
60	ANKASCREW™ XTREM™ - FIRE RATED MECH. ANCHOR	339
61	EPCON™ C8 XTREM™ - FIRE RATED CHEM. ANCHOR	345
62	CHEMSET™ 801 XTREM™ XC ² - FIRE RATED CHEM. ANCHOR	350
SPECIFIERS RESOURCE BOOK DESIGN WORKSHEETS		
		351

Legend of Symbols

SPECIFIERS RESOURCE GUIDE

[Back to index](#)

We have developed this set of easily recognisable icons to assist with product selection.

PERFORMANCE RELATED SYMBOLS

Indicates the suitability of product to specific types of performance related situations.

- 

Has good resistance to cyclic and dynamic loading. Resists loosening under vibration.
- 

Anchor has an effective pull-down feature, or is a stud anchor. It has the ability to clamp the fixture to the base material and provide high resistance to cyclic loading.
- 

Suitable for use in seismic design according to ANZ Standards (eg AS/NZ 1170.4) or independent seismic performance data available from either an ICC Evaluation report or European Technical Assessment.
- 

Cracked concrete.
- 

Fire rated in accordance with the applicable standard or independent assessment (i.e. Australian Standards or European Technical Assessment)
- 

May be used close to edges (or another anchor) without risk of splitting the concrete.
- 

Temporary or removable anchor.

MATERIAL SPECIFICATION SYMBOLS

Indicates the base material and surface finish to assist in selection with regard to corrosion or environmental issues.

- 

Steel Zinc Plated
Minimum thickness 5 micron.
Recommended for internal applications only.
- 

Steel Hot Dipped Galvanised to AS/NZS4680-2006 and AS/NZS 1214 - 2016.
Minimum thickness 42 micron.
For external applications.
- 

Steel Mechanically Galvanised
Minimum thickness 42 micron.
For external applications.
- 

Climaseal
Minimum thickness 75 microns.
For internal applications.
- 

AISI Grade 316 Stainless Steel, resistant to corrosive agents including chlorides and industrial pollutants. Recommended for internal or external applications in marine or corrosive environments.
- 

Stainless Steel High Corrosion resistance.
HCR Grade 1.4529/1.4565.
- 

Corrosion resistant.
Not recommended for direct exposure to sunlight.

INSTALLATION RELATED SYMBOLS

Indicates the suitable positioning and other installation related requirements.

- 

Suitable for floor applications.
- 

Suitable for wall applications.
- 

Suitable for overhead applications.
- 

Suitable for hollow brick/block and hollow core concrete applications.
- 

Anchor can be through fixed into substrate using fixture as template.
- 

Suitable for AAC and lightweight concrete applications.
- 

Anchors suitable for use in dry holes.
- 

Anchors suitable for use in damp holes.
- 

Anchors suitable for use in holes filled with water.
- 

Suitable for use in drilled holes.
- 

Suitable for use in cored holes.
- 

Suitable for contact with drinking water for human consumption.

Back to index

Notation

SPECIFIERS RESOURCE GUIDE

Notation

GENERAL NOTATION

a	=	actual anchor spacing	(mm)	k_2	=	AS3600 - 2018		X_{ncr}	=	cracked concrete effect, tension	
a_c	=	critical anchor spacing	(mm)	k_3	=	AS3600 - 2018		X_{ne}	=	edge distance effect, tension	
a_m	=	absolute minimum anchor spacing	(mm)	L	=	anchor length	(mm)	X_{uc}	=	characteristic ultimate capacity	
A_b	=	reinforcing bar stress area	(mm ²)	L_e	=	anchor effective length	(mm)	X_{va}	=	anchor spacing effect, concrete edge shear	
A_s	=	stress area	(mm ²)	L_{st}	=	length of reinforcing bar to develop tensile stress σ_{st}	(mm)	X_{vc}	=	concrete compressive strength effect, shear	
A_{st}	=	stress area of reinforcing bar	(mm ²)	L_{syt}	=	reinforcing bar length to develop steel yield in tension	(mm)	X_{vcr}	=	cracked concrete effect, shear	
b_m	=	minimum substrate thickness	(mm)	$L_{syt(nom)}$	=	length of reinforcing bar to develop full steel yield in 32 MPa concrete	(mm)	X_{vd}	=	load direction effect, concrete edge shear	
d_b	=	bolt diameter	(mm)	L_t	=	thread length	(mm)	X_{ve}	=	concrete anchor spacing and edge distance effect, shear	
d_f	=	fixture hole diameter	(mm)	n	=	number of fixings in a group		X_{vn}	=	multiple anchors effect, concrete edge shear	
d_h	=	drilled hole diameter	(mm)	N_{sy}	=	tensile steel yield load capacity		X_{vs}	=	corner edge shear effect, shear	
e	=	actual edge distance	(mm)	N_{ub}	=	characteristic ultimate tensile adhesive bond capacity	(kN)	X_{vsc}	=	concrete compressive strength effect, combined concrete/steel shear	
e_c	=	critical edge distance	(mm)	P_L	=	long term, retained preload	(kN)	X_{ns}	=	Cracked concrete service temperature limits effect	
e_m	=	absolute minimum edge distance	(mm)	P_{Li}	=	initial preload	(kN)	Z	=	section modulus (mm ³)	
f_c	=	concrete cylinder characteristic compressive strength	(MPa)	P_r	=	proof load	(kN)	β	=	concrete cube characteristic compressive strength (N/mm ²)	
f_{ct}	=	concrete flexural tensile strength	(MPa)	t	=	total thickness of fastened material(s)	(mm)	μ_T	=	torque co-efficient of sliding friction	
f_{sy}	=	reinforcing bar steel yield strength	(MPa)	T_r	=	assembly torque	(Nm)	x	=	mean ultimate capacity	
f_u	=	characteristic ultimate steel tensile strength	(MPa)	X_{na}	=	anchor spacing effect, tension		σ_{st}	=	steel tensile stress	
f_y	=	characteristic steel yield strength	(MPa)	X_{nae}	=	anchor spacing effect, end of a row, tension		$\sigma_{st(nom)}$	=	steel tensile stress of reinforcing bar bonded into 32 MPa concrete	
h	=	anchor effective depth	(mm)	X_{nai}	=	anchor spacing effect, internal to a row, tension					
h_n	=	nominal effective depth	(mm)	X_{nc}	=	concrete compressive strength effect, tension					
g	=	gap or non-structural thickness	(mm)								
k_1	=	AS3600 - 2018									

STRENGTH LIMIT STATE NOTATION

M	=	design bending action effect	(kN.m)	N_{us}	=	characteristic ultimate steel tensile capacity	(kN)	ϕ	=	capacity reduction factor	
M_u	=	characteristic ultimate moment capacity	(kN.m)	N_{usr}	=	factored characteristic ultimate steel tensile capacity	(kN)	ϕ_c	=	capacity reduction factor, concrete tension recommended as 0.6	
N^*	=	design tensile action effect	(kN)	R_u	=	characteristic ultimate capacity		ϕ_m	=	capacity reduction factor, steel bending recommended as 0.8	
N_{ut}	=	nominal ultimate bolt tensile capacity	(kN)	V^*	=	design shear action effect	(kN)	ϕ_n	=	capacity reduction factor, steel tension recommended as 0.8	
N_u	=	characteristic ultimate tensile capacity	(kN)	V_{st}	=	nominal ultimate bolt shear capacity	(kN)	ϕ_q	=	capacity reduction factor, concrete edge shear recommended as 0.6	
N_{uc}	=	characteristic ultimate concrete tensile capacity	(kN)	V_u	=	ultimate shear capacity	(kN)	ϕ_v	=	capacity reduction factor, steel shear recommended as 0.8	
N_{up}	=	characteristic ultimate pull-through capacity	(kN)	V_{uc}	=	characteristic ultimate concrete edge shear capacity	(kN)	ϕ_p	=	capacity reduction factor, pull-through recommended as 0.65	
N_{ucr}	=	factored characteristic ultimate concrete tensile capacity	(kN)	V_{ucp}	=	ultimate concrete pryout capacity					
N_{ur}	=	design ultimate tensile capacity	(kN)	V_{ur}	=	design ultimate shear capacity	(kN)				
N_{urc}	=	design ultimate concrete tensile capacity	(kN)	V_{urc}	=	design ultimate concrete edge shear capacity	(kN)				
N_{urp}	=	design ultimate pull-through capacity	(kN)	V_{urcp}	=	design ultimate concrete pryout capacity					
N_{ucc}	=	concrete cone resistance		V_{us}	=	characteristic ultimate steel shear capacity	(kN)				
N_{ucp}	=	combined pull-out and concrete cone resistance		V_{usc}	=	characteristic ultimate combined concrete/steel shear capacity	(kN)				

PERMISSIBLE STRESS NOTATION

f_s	=	factor of safety		N_{ac}	=	working load limit concrete tensile capacity	(kN)	V_a	=	working load limit shear capacity	(kN)
f_{sc}	=	factor of safety for substrate = 3.0		N_{ar}	=	factored working load limit tensile capacity	(kN)	V_{ar}	=	factored working load limit shear capacity	(kN)
f_{ss}	=	factor of safety for steel in tension and bending = 2.2		N_{as}	=	working load limit steel tensile capacity	(kN)	V_{as}	=	working load limit steel shear capacity	(kN)
f_{sv}	=	factor of safety for steel in shear = 2.5		N_{asr}	=	factored working load limit steel tensile capacity	(kN)				
M	=	applied moment	(kNm)	R_b	=	working load limit capacity	(kN)				
M_a	=	working load limit moment capacity	(kNm)	V	=	applied shear load	(kN)				
N	=	applied tensile load	(kN)								
N_a	=	working load limit tensile capacity	(kN)								

Notation/Design Process

SPECIFIERS RESOURCE GUIDE

[Back to index](#)

STRENGTH LIMIT STATE NOTATION (SEISMIC ANCHORS)

ACI - US Seismic Design Method

N_{ucc} = Seismic cracked concrete cone characteristic ultimate tensile resistance	$V_{uc,seis}$ = Seismic cracked concrete characteristic ultimate edge shear resistance	$\alpha_{N,seis}$ = Seismic capacity reductions factor for steel tension
N_{ucp} = Seismic cracked concrete pull-out bond characteristic ultimate tensile resistance	$V_{cp,seis}$ = Seismic cracked concrete characteristic ultimate Pryout failure	$\alpha_{V,seis}$ = Seismic capacity reductions factor for steel shear
N_{urcc} = Design seismic cracked concrete cone ultimate tensile resistance	$V_{urc,seis}$ = Design seismic cracked concrete ultimate edge shear resistance	
N_{urcp} = Design seismic cracked concrete pull-out bond ultimate tensile resistance	$V_{urcp,sei}$ = Design seismic cracked concrete ultimate Pryout failure	
$N_{ur,seis}$ = Design seismic cracked ultimate tensile resistance	$V_{ur,seis}$ = Design seismic cracked ultimate shear resistance	

EOTA - European Seismic Design Method

$N_{Rd,p,seis}$ = Design seismic cracked concrete combined Pull-out and concrete cone resistance, tension	$V_{Rd,c,seis}^0$ = Seismic cracked concrete edge shear resistance	γ_{Ms} = Partial safety factor for steel resistance (tension and shear)
$N_{Rd,p,seis}^0$ = Seismic cracked concrete combined Pull-out and concrete cone resistance, tension	$V_{Rd,cp,seis}^0$ = Seismic cracked concrete pryout failure	γ_{Msp} = Partial safety factor for combined pull-out concrete cone (pull-through) resistance
$N_{Rd,s,seis}$ = Design seismic cracked concrete steel tensile resistance - reduced characteristic	$V_{Rd,s,seis}$ = Seismic cracked concrete steel shear resistance	γ_{Mc} = Partial safety factor for concrete edge failure
$N_{Rd,seis}$ = Design seismic cracked tensile resistance	$V_{Rd,seis}$ = Design seismic cracked concrete edge shear resistance	γ_{Mpr} = Partial safety factor for concrete pryout failure
$N_{Rk,c}$ = Seismic cracked concrete cone resistance - characteristic	$V_{Rk,c}^0$ = Seismic cracked concrete edge resistance - characteristic	
$N_{Rk,p}^0$ = Seismic cracked concrete pull-out (pull-through) concrete cone resistance - characteristic	$V_{Rk,cp}$ = Seismic cracked concrete Pryout failure - characteristic	
$N_{Rk,s}$ = Seismic cracked concrete steel tensile resistance - characteristic	$V_{Rk,s}$ = Seismic cracked concrete steel shear resistance - characteristic	

Simplified Design

APPROACH

Design Process

DESIGN PROCESS

This information is provided for the guidance of qualified structural engineers or other suitably skilled persons in the design of anchors. It is the designer's responsibility to ensure compliance with the relevant standards, codes of practice, building regulations, workplace regulations and statutes as applicable.

This manual allows the designer to determine load carrying capacities based on actual application and installation conditions. The designer must first select the anchor style/type to suit application and environmental conditions through the use of tables 4.1, 4.2, 4.3, 4.4 and 4.5 to identify the specific product features, dimensional properties and environmental characteristics required.

Then select an appropriate anchor size to meet the required load case through the use of either the working load information provided or by use of the simplified design process described on the page opposite to arrive at recommendations in line with strength limit state design principles.

Ramset™ has developed this **Simplified Design Approach** to achieve strength limit state design, and to allow for rapid selection of a suitable anchor and through systematic analysis, establish that it will meet the required design criteria under strength limit state principles. The necessary diagrams, tables etc. for each specific product are included in this publication.

Ramset™ has also developed a software tool "**i-Expert Anchor Design**" to enable engineers to quickly select suitable anchors for a specific set of design conditions and output the results for project file reference. We have developed this design process to provide accurate anchor performance predictions and allow appropriate design solutions in an efficient and time saving manner.

Our experience over many years of anchor design has enabled us to develop this process which enables accurate and quick solutions without the need to work laboriously from first principles each time.

PRELIMINARY SELECTION

Establish the design action effects, N^* and V^* (Tension and Shear) acting on each anchor being examined using the appropriate load combinations detailed in the **AS1170** series of Australian Standards and **NZS1170** series of New Zealand Standards.

Refer to charts on pages 17, 18, 19, 20 and 21 in order to select an anchor type that best meets the needs of your application.

STRENGTH LIMIT STATE DESIGN

STEP 1 Select anchor to be evaluated

Refer to table 1a, 'Indicative combined loading – Interaction Diagram' for the anchor type selected, looking up N^* and V^* to select the anchor size most likely to meet the design requirements.

Note that the Interaction Diagram is for a specific concrete compressive strength and does not consider edge distance and anchor spacing effects, hence is a guide only and its use should not replace a complete design process.

ACTION **Note down the anchor size selected.**

Having selected an anchor size, check that the design values for edge distance and anchor spacing comply with the absolute minima detailed in table 1b. If your design values do not comply, adjust the design layout.

Calculate the anchor effective depth as detailed in step 1c.

This is an important structural dimension that will be referred to in subsequent tables.

Typically, greater effective depths will result in greater concrete tensile capacities.

ACTION **Note down the anchor effective depth, h.**
Note also the product part no. referenced.

Checkpoint 1

- Anchor size selected ?
- Absolute minima compliance achieved ?
- Anchor effective depth calculated ?

If the above questions are answered satisfactorily, proceed to step 2.

Simplified Design

APPROACH

STEP 2 Verify concrete tensile capacity - per anchor

Referring to table 2a, determine the reduced characteristic ultimate concrete tensile capacity (ϕN_{uc}). This is the basic capacity, uninfluenced by edge distance or anchor spacings and is for the specific concrete compressive strength(s) noted.

ACTION Note down the value for ϕN_{uc}

When cracked concrete design is required, apply X_{ncr} effect factor in table 2a-2

ACTION Note down the value for X_{ncr}

Check concrete service temperature limit in table 2b-1 and apply service temperature limits effect, tension, X_{ns} as required

ACTION Note down the value for X_{ns}

Calculate the concrete compressive strength effect, tension, X_{nc} by referring to table 2b-2. This multiplier considers the influence of the actual concrete compressive strength compared to that used in table 2a above.

ACTION Note down the value for X_{nc}

If the concrete edge distance is close enough to the anchor being evaluated, that anchors tensile performance may be reduced. Use table 2c, edge distance effect, tension, X_{ne} to determine if the design edge distance influences the anchors tensile capacity.

ACTION Note down the value for X_{ne}

For designs involving more than one anchor, consideration must be given to the influence of anchor spacing on tensile capacity. Use Table 2d to establish the anchor spacing effect, tension, X_{na}

ACTION Note down the value of X_{na}

Checkpoint 2

Design reduced ultimate concrete tensile capacity, ϕN_{urc}

$$\phi N_{urc} = \phi N_{uc} * X_{ncr} * X_{ns} * X_{nc} * X_{ne} * X_{na}$$

If Service temperature limit is -40°C to +40°C then

$$\phi N_{urc} = \text{minimum of } \phi N_{ucp} * X_{ncr} * X_{ns} * X_{nc} * X_{ne} * X_{na} \text{ and } \phi N_{uc} * X_{ncr} * X_{ns} * X_{nc} * X_{ne} * X_{na}$$

This calculation takes into consideration the influences of concrete compressive strength, edge distance and anchor spacing to arrive at the design reduced concrete tensile capacity.

ACTION Note down the value of ϕN_{urc}

STEP 3 Verify anchor tensile capacity - per anchor

Having calculated the concrete tensile capacity above (ϕN_{urc}), consideration must now be given to other tensile failure mechanisms.

Calculate the reduced characteristic ultimate steel tensile capacity (ϕN_{us}) from table(s) 3a.

ACTION Note down the value of ϕN_{us}

For internally threaded anchoring products that utilise a separate bolt such as the Threaded Insert anchor, make use of step 3b to verify the reduced characteristic ultimate bolt steel tensile capacity (ϕN_{tf}).

Checkpoint 3

Now that we have obtained capacity information for all tensile failure mechanisms, verify which one is controlling the design.

Design reduced ultimate tensile capacity, ϕN_{ur}

$$\phi N_{ur} = \text{minimum of } \phi N_{urc}, \phi N_{us}, \phi N_{tf}$$

Check $N^* / \phi N_{ur} \leq 1$,

if not satisfied return to step 1

This completes the tensile design process, we now look to verify that adequate shear capacity is available.

Simplified Design APPROACH

Design Process

STEP 4 Verify concrete shear capacity - per anchor

Referring to table 4a, determine the reduced characteristic ultimate concrete edge shear capacity (ϕV_{uc}). This is the basic capacity, uninfluenced by anchor spacings and is for the specific edge distance and concrete compressive strength(s) noted.

ACTION Note down the value for ϕV_{uc}

When cracked concrete design is required, apply X_{vcr} effect factor in table 4a-2

ACTION Note down the value for X_{vcr}

Calculate the concrete compressive strength effect, shear, X_{vc} by referring to table 4b. This multiplier considers the influence of the actual concrete compressive strength compared to the nominal value used in table 4a above.

ACTION Note down the value for X_{vc}

The angle of incidence of the shear load acting towards an edge is considered through the factor X_{vd} , load direction effect, shear.

Use table 4c to establish its value.

ACTION Note down the value for X_{vd}

For a row of anchors located close to an edge, the influence of the anchor spacing on the concrete edge shear capacity is considered by the factor X_{ve} , Concrete anchor spacing and edge distance effect, concrete edge shear.

Note that this factor considers single anchor, two anchor and three or more anchors loaded equally..

ACTION Note down the value for X_{ve}

Calculate the reduced characteristic concrete pryout capacity, V_{ucp} by referring to table 4e. This considers concrete pryout capacity on anchors.

ACTION Note down the value for V_{ucp}

Calculate the anchor at a corner effect, concrete edge shear, X_{na} by referring to table 4f. This considers concrete capacity limitations when an anchor is influenced by two concrete edges.

ACTION Note down the value for X_{na}

Examples

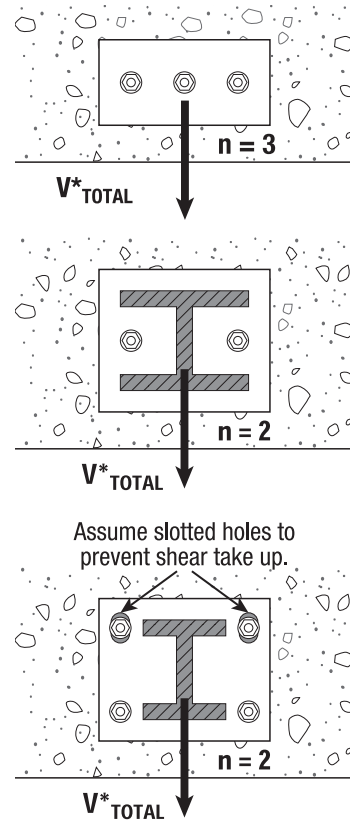

Note: Consider capacity of two anchors in row closest to edge only,
ie. anchor load = $V_{TOTAL}^*/2$ to each anchor.

Checkpoint 4a Design reduced ultimate concrete edge shear capacity, ϕV_{urc}
 $\phi V_{urc} = \phi V_{uc} * X_{vcr} * X_{vc} * X_{vd} * X_{ve} * X_{na}$

Checkpoint 4b Design reduced ultimate concrete pryout capacity,
 ϕV_{urcp}
 $\phi V_{urcp} = \phi V_{ucp} * X_{ncr} * X_{nc} * X_{ne} * X_{na}$

This calculation takes into consideration the influences of concrete compressive strength, edge distance and anchor spacing to arrive at the design reduced concrete shear capacity.

For a design involving two or more anchors in a row parallel to an edge, this value is the average capacity of each anchor assuming each is loaded equally.

ACTION Note down the value of ϕV_{urc}

Simplified Design

APPROACH

STEP 5 Verify anchor shear capacity - per anchor

Having calculated the concrete shear capacity above (ϕV_{urc}), consideration must now be given to other shear failure mechanisms.

Calculate the reduced characteristic ultimate steel shear capacity (ϕV_{us}) from table(s) 5a.

ACTION Note down the value for ϕV_{us}

For internally threaded anchoring products that utilise a separate bolt such as the Threaded Insert anchor, make use of step 5b to verify the reduced characteristic ultimate bolt steel shear capacity (ϕV_{sf}).

Checkpoint 5

Design reduced shear capacity, ϕV_{ur}

Now that we have obtained capacity information for all shear failure mechanisms, verify which one is controlling the design.

$\phi V_{ur} = \text{minimum of } \phi V_{urc}, \phi V_{us}, \phi V_{sf}, V_{urcp}$

Check $V^* / \phi V_{ur} \leq 1$,

if not satisfied return to step 1

This completes the shear design process, we now look to verify that adequate combined capacity is available for load cases having both shear and tensile components.

STEP 6 Combined loading and specification

For load cases having both tensile and shear components, verify that the relationship represented here is satisfied.

Checkpoint 6

Check

$N^* / \phi N_{ur} + V^* / \phi V_{ur} \leq 1.2$,

if not satisfied return to step 1

Specify the product to be used as detailed.

Worked Example

STRENGTH LIMIT STATE DESIGN

Design Process

Verify capacity of the anchors detailed below:

Given data:

Concrete compressive strength	f_c	50 MPa
Design tensile action effect	N^*_{TOTAL}	72 kN
Design shear action effect	V^*_{TOTAL}	40 kN
Edge distance	e	250 mm
Anchor spacing	a	150 mm
Fixture plate + grout thickness	t	17 mm
No. of anchors in shear	n	4
Concrete condition	non-cracked	

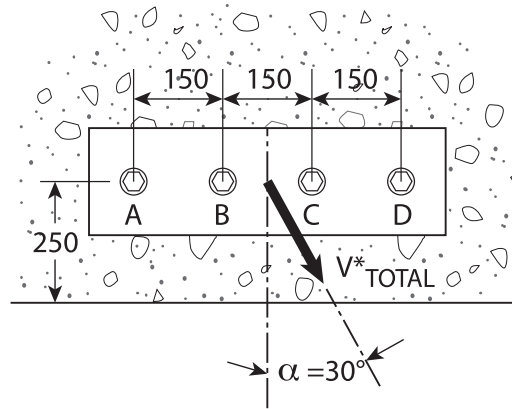

As the design process considers design action effects PER anchor, distribute the total load case to each anchor as is deemed appropriate.

In this case, equal load distribution is considered appropriate hence,

Design tensile action effect (per anchor)	N^*	18 kN
Design shear action effect (per anchor)	V^*	10 kN

Given that each of the 'interior' anchors is influenced by two adjacent anchors, verify capacity for anchor 'B' in this case.

From the information presented in tables 4.1 – 4.5, it is established that SpaTec™ Xtrem™ anchors will be suitable for selection.

Having completed the preliminary selection component of the design process, commence the Strength Limit State Design process.

Worked Example

STRENGTH LIMIT STATE DESIGN

STEP 1 Select anchor to be evaluated

Refer to table 1a, 'Indicative combined loading - interaction diagram' on page 259. Applying both the N^* value and V^* value to the interaction, it can be seen that the intersection of the two values falls within the M16 "band".

ACTION M16 anchor size selected.

Confirm that absolute minima requirements are met.

From table 1b (page 257) for M16 SpaTec Xtrem™, it is required that edge distance, $e > 180$ mm. and that anchor spacing, $a > 100$ mm.

The design values of $e = 250$ mm and $a = 150$ mm comply with these minima, hence continue to step 1c.

The effective depth, h , is calculated by making reference to the 'Description and Part Numbers' table on page 258 and calculating effective depth, $h = L_e - t$.

Hence,
$$h = 125 - 17 = 108 \text{ mm}$$

**ACTION $h = 108$
Anchor selected is SP16145**

Checkpoint 1

Anchor size selected ?	M16
Absolute minima compliance achieved ?	Yes
Anchor effective depth calculated ?	$h = 108$ mm with SP16145

STEP 2 Verify concrete tensile capacity - per anchor

Referring to table 2a, consider the value obtained for an M16 anchor at $h = 100$ mm (closest to our design value of $h = 108$ mm).

ACTION $\phi N_{uc} = 41.4$ kN

Verify concrete condition, cracked or un-cracked. In this example, concrete is un-cracked.

Action $X_{ncr} = 1.0$ (no effect)

Verify the concrete compressive strength effect, tension, X_{nc} value from table 2b.

ACTION $X_{nc} = 1.25$

Verify the edge distance effect, tension, X_{ne} value from table 2c.

ACTION $X_{ne} = 1.00$ (no effect)

As we are considering anchor 'B' for this example, use table 2d on page 260 to verify the anchor spacing effect, internal to a row, tension, X_{na} value. If we were inspecting anchors 'A' or 'D' we would use table 2d for anchors at the end of a row.

ACTION $X_{na} = 0.75$

Checkpoint 2

<p>Design reduced concrete tensile capacity, ϕN_{urc}</p> $\begin{aligned} \phi N_{urc} &= \phi N_{uc} \cdot X_{ncr} \cdot X_{nc} \cdot X_{ne} \cdot X_{na} \\ &= 41.4 \cdot 1.0 \cdot 1.25 \cdot 1.0 \cdot 0.75 \\ &= 38.8 \text{ kN} \end{aligned}$

ACTION $\phi N_{urc} = 38.8$ kN

Worked Example

STRENGTH LIMIT STATE DESIGN

Design Process

STEP 3 Verify anchor tensile capacity - per anchor

From table 3a, verify the reduced characteristic ultimate steel tensile capacity, ϕN_{us} .

For an M16 SpaTec Plus, $\phi N_{us} = 84.0$ kN.

ACTION $\phi N_{us} = 84.0$ kN

Checkpoint 3

$\phi N_{ur} = \text{minimum of } \phi N_{urcr} \phi N_{us}$

In this case $\phi N_{ur} = 38.8$ kN (governed by concrete capacity).

Check $N^* / \phi N_{ur} \leq 1$,

$$18 / 38.8 = 0.46 \leq 1$$

Tensile design criteria satisfied, proceed to Step 4.

STEP 4 Verify concrete shear capacity - per anchor

Referring to table 4a, consider the value obtained for an M16 anchor at $e = 250$ mm.

ACTION $\phi V_{uc} = 16.6$ kN

Verify concrete condition, cracked or un-cracked. In this example, concrete in un-cracked.

ACTION $X_{ucr} = 1.0$ (no effect)

Verify the concrete compressive strength effect, tension, X_{vc} value from table 4b.

ACTION $X_{vc} = 1.27$

Verify the load direction effect, concrete edge shear, X_{vd} value using table 4c.

ACTION $X_{vd} = 1.0$ for angle of 30 degrees to normal.

Verify the anchor spacing and edge distance effect, concrete edge shear, X_{ve} value using X_{ve} formula below table 4d when 3 or more anchors are in a row.

ACTION $X_{ve} = 0.65$

Verify concrete pryout capacity, V_{ucp} from table 4e

ACTION $V_{ucp} = 83.3$ kN

Verify anchor at a corner effect, concrete edge shear, X_{vs}

ACTION $X_{vs} = 1.00$

Checkpoint 4a

Design reduced ultimate concrete edge shear capacity, ϕV_{urc}

$$\begin{aligned} \phi V_{urc} &= \phi V_{uc} * X_{ucr} * X_{vc} * X_{vd} * X_e * X_{vs} \\ &= 16.6 * 1.27 * 1.0 * 0.65 * 1.0 * 1.0 \\ &= 13.7 \end{aligned}$$

ACTION $\phi V_{urc} = 13.7$ kN

Checkpoint 4b

Design reduced ultimate concrete pryout capacity,

$$\begin{aligned} \phi V_{urcp} &= \phi V_{ucp} * X_{ncr} * X_{nc} * X_{ne} * X_{na} \\ &= 83.3 * 1.0 * 1.0 * 1.0 * 1.0 \\ &= 83.3 \end{aligned}$$

ACTION $\phi V_{urcp} = 77.8$ kN

STEP 5 Verify anchor shear capacity - per anchor

From table 5a, verify the reduced characteristic ultimate steel shear capacity, ϕV_{us} .

The shear capacity available from the SpaTec Plus anchor is subject to its effective depth, h value. As was noted earlier $h = 108$ mm for this example, hence,

for an M16 SpaTec Plus at $h = 108$ mm, $\phi V_{us} = 78.5$ kN

ACTION $\phi V_{us} = 78.5$ kN

Checkpoint 5

$\phi V_{ur} = \text{minimum of } \phi V_{urcr} \phi V_{us}$

In this case $\phi V_{ur} = 13.7$ kN (governed by concrete capacity).

Check $V^* / \phi V_{ur} \leq 1$,

$$10 / 13.7 = 0.73 \leq 1$$

Shear design criteria satisfied, proceed to Step 6.

Worked Example

STRENGTH LIMIT STATE DESIGN

STEP 6 Combined loading and specification

Checkpoint 6

Now, ensure combined loading criteria is met.

$$N^*/\phi N_{ur} + V^*/\phi V_{ur} \leq 1.2,$$

$$18 / 38.8 + 10 / 13.7 = 1.19$$

Combined loading criteria **PASSES**.

Specify

Ramset™ SpaTec™ Plus Anchor,
M16 (SP16145).

Maximum fixed thickness to be 17 mm.

To be installed in accordance with
Ramset Technical Data Sheet

If combined loading criteria is >1.2 and fails, review the design process and examine the critical factors influencing the overall anchor capacity. Make adjustments where required (e.g. increase edge distance, anchor spacing, anchor size, effective depth, concrete strength) and re-calculate design to achieve a suitable design.

Considerations

ENVIRONMENTAL / INSTALLATION

[Back to index](#)

Anchor Selection Guide

Environmental Considerations

	ANCHOR														
	Space-Xtrem™	Boa™ Coil	Tri-Bolt™ Xtrem™	Tri-Bolt™	AnkaScrew™ Xtrem™	WERCS AnkaScrew™	Dynabolt™ Plus	DynaSet™	RamPlug™	Chemset™ Reo502™ PLUS	EPCON™ C8 Xtrem™	EPCON™ C6 PLUS	Chemset™ 801 Xtrem™ XC™	Chemset™ 101 PLUS	Chemset™ Spin Capsules
Coastal Environment External			✓(SS)				✓(SS)	✓(SS)		✓(SS)	✓(SS)	✓(SS)	✓(SS)	✓(SS)	✓(SS)
Coastal Environment Internal			✓(SS)	✓(Gal)		✓(Gal)	✓(Gal)	✓(SS)		✓(Gal)	✓(Gal)	✓(Gal)	✓(Gal)	✓(Gal)	✓(Gal)
Inland Environment External	✓(Zn)	✓(Zn)	✓(Zn)		✓(Zn)	✓(Zn)	✓(Zn)	✓(Zn)		✓(Zn)	✓(Zn)	✓(Zn)	✓(Zn)	✓(Zn)	✓(Zn)
Inland Environment Internal	✓(Zn)	✓(Zn)	✓(Zn)		✓(Zn)	✓(Zn)	✓(Zn)	✓(Zn)	✓	✓(Zn)	✓(Zn)	✓(Zn)	✓(Zn)	✓(Zn)	✓(Zn)
Tropical Environment External			✓(SS)	✓(Gal)		✓(Gal)	✓(Gal)	✓(SS)		✓(Gal)	✓(Gal)	✓(Gal)	✓(Gal)	✓(Gal)	✓(Gal)
Alpine Environment External			✓(SS)	✓(Gal)		✓(Gal)	✓(Gal)	✓(SS)		✓(Gal)	✓(Gal)	✓(Gal)	✓(Gal)	✓(Gal)	✓(Gal)
Alpine Environment Internal	✓(Zn)	✓(Zn)	✓(Zn)		✓(Zn)	✓(Zn)	✓(Zn)	✓(Zn)	✓	✓(Zn)	✓(Zn)	✓(Zn)	✓(Zn)	✓(Zn)	✓(Zn)
Industrial Environment External			✓(SS)				✓(SS)	✓(SS)		✓(SS)	✓(SS)	✓(SS)	✓(SS)	✓(SS)	✓(SS)
Industrial Environment Internal			✓(SS)				✓(SS)	✓(SS)		✓(SS)	✓(SS)	✓(SS)	✓(SS)	✓(SS)	✓(SS)
Internal Wet Areas			✓(SS)	✓(Gal)		✓(Gal)	✓(Gal)	✓(SS)		✓(Gal)	✓(Gal)	✓(Gal)	✓(Gal)	✓(Gal)	✓(Gal)

Installation Considerations

	ANCHOR														
	Space-Xtrem™	Boa™ Coil	Tri-Bolt™ Xtrem™	Tri-Bolt™	AnkaScrew™ Xtrem™	WERCS AnkaScrew™	Dynabolt™ Plus	DynaSet™	RamPlug™	Chemset™ Reo502™ PLUS	EPCON™ C8 Xtrem™	EPCON™ C6 PLUS	Chemset™ 801 Xtrem™ XC™	Chemset™ 101 PLUS	Chemset™ Spin Capsules
Dry Hole	✓	✓	✓	✓	✓	✓	✓	✓	✓	✓	✓	✓	✓	✓	✓
Damp Hole			✓(SS)	✓(Gal)		✓(Gal)	✓(Gal)	✓(SS)	✓	✓(Gal)	✓(Gal)	✓(Gal)	✓(Gal)	✓(Gal)	✓(Gal)
Water Filled Hole			✓(SS)				✓(SS)	✓(SS)		✓(SS)	✓(SS)	✓(SS)		✓(SS)	
Submerged Hole After Set			✓(SS)				✓(SS)	✓(SS)		✓(SS)	✓(SS)	✓(SS)	✓(SS)	✓(SS)	✓(SS)
Fire Resistant	✓	✓	✓		✓	✓	✓	✓			✓				
Fire Rated	✓		✓		✓	✓		✓			✓		✓		
Solid Concrete	✓	✓	✓	✓	✓	✓	✓	✓	✓	✓	✓	✓	✓	✓	✓
Hollow Block (Cavity)					✓	✓	✓		✓					✓*	
Solid Clay Brick					✓	✓	✓		✓	✓		✓	✓	✓	✓
Wire Cut Clay Brick					✓	✓	✓		✓			✓*		✓*	
Cracked Concrete	✓		✓		✓					✓	✓	✓	✓		
Selsmic Loading	✓		✓		✓					✓	✓	✓	✓		
Sustained Loading	✓		✓		✓					✓	✓	✓	✓	✓	✓

* With accessories

LEGEND ✓ = Recommended

Anchor Feature GUIDE

The following chart provides a quick guide for selecting the appropriate **Ramset** Concrete Anchor to suit your needs. Please refer to the Legend of Symbols below each table for a detailed explanation of the symbols used.

Anchor Feature Guide

PRODUCT	PERFORMANCE RELATED							MATERIAL SPECIFICATION						
SpaTec™ Xtrem™ Safety Anchor	✓	✓	✓	✓			✓	✓						
Boa™ Coil Anchor	✓	✓				✓	✓							
TruBolt™ Anchor Xtrem™	✓	✓	✓	✓			✓	✓			✓			
TruBolt™ Anchor	✓	✓								✓				
AnkaScrew™ Xtrem™	✓	✓	✓	✓			✓	✓						
WERCS AnkaScrew™ Screw-In Anchor	✓	✓		✓	✓	✓	✓		✓					
DynaBolt™ Plus Anchor	✓	✓					✓			✓	✓			
DynaBolt™ Plus Anchor Hex Bolt	✓	✓					✓			✓	✓			
DynaSet™ Drop-In Anchor		✓		✓			✓				✓			
RamPlug™ Anchor		✓				✓							✓	
ChemSet™ Reo 502™ PLUS Injection & Stud	✓	✓	✓		✓		✓	✓		✓	✓	✓		
ChemSet™ Reo 502™ PLUS Injection & Thr'd Insert	✓	✓			✓		✓				✓			
ChemSet™ Reo 502™ PLUS Injection & Rebar	✓		✓		✓		✓							
EPCON™ C8 Xtrem™ Injection & Stud	✓	✓	✓		✓		✓	✓		✓	✓	✓		
EPCON™ C8 Xtrem™ Injection & Rebar	✓		✓	✓	✓		✓							
EPCON™ C6 PLUS Injection & Stud	✓	✓	✓		✓		✓	✓		✓	✓	✓		
EPCON™ C6 PLUS Injection & Threaded Insert	✓	✓			✓		✓				✓			
EPCON™ C6 PLUS Injection & Rebar	✓		✓		✓		✓							
ChemSet™ 801 Xtrem™ XC² Injection & Stud	✓	✓	✓	✓	✓		✓	✓		✓	✓	✓		
ChemSet™ 801 Xtrem™ XC² & Thr'd Insert	✓	✓			✓		✓				✓			
ChemSet™ 801 Xtrem™ XC² & Rebar	✓		✓		✓		✓	✓						
ChemSet™ 101 PLUS Injection & Stud	✓	✓			✓		✓			✓	✓			
ChemSet™ Maxima™ Spin Capsule & Stud	✓	✓			✓		✓			✓	✓			

LEGEND ✓ = Recommended

PERFORMANCE RELATED SYMBOLS

Indicates the suitability of product to specific types of performance related situations.

- Has good resistance to cyclic and dynamic loading. Resists loosening under vibration.
- Anchor has an effective pull-down feature, or is a stud anchor. It has the ability to clamp the fixture to the base material and provide high resistance to cyclic loading.
- Fire rated in accordance with the applicable standard or independent assessment (i.e. Australian Standards or European Technical Assessment)
- May be used close to edges (or another anchor) without risk of splitting the concrete.
- Temporary or removable anchor.
- Suitable for use in seismic design according to ANZ Standards (eg AS/NZ 1170.4) or independent seismic performance data available from either an ICC Evaluation report or European Technical Assessment.

MATERIAL SPECIFICATION SYMBOLS

Indicates the base material and surface finish to assist in selection with regard to corrosion or environmental issues.

- Steel Zinc Plated
Minimum thickness 5 micron.
Recommended for internal applications only.
- AISI Grade 316 Stainless Steel, resistant to corrosive agents including chlorides and industrial pollutants. Recommended for internal or external applications in marine or corrosive environments.
- Climaseal
Minimum thickness 75 microns.
For internal applications.
- Steel Hot Dipped Galvanised to AS/NZS4680-2006 and AS/NZS 1214 - 2016.
Minimum thickness 42 micron.
For external applications.
- Stainless Steel High Corrosion resistance.
HCR Grade 1.4529/1.4565.
- Steel Mechanically Galvanised
Minimum thickness 42 micron.
For external applications.
- Corrosion resistant.
Not recommended for direct exposure to sunlight.

Anchor Application GUIDE

Anchor Application Guide

PRODUCT	APPLICATIONS												
SpaTec™ Xtrem™ Safety Anchor	✓	✓	✓		✓	✓			✓	✓			
Boa™ Coil Anchor	✓	✓	✓		✓	✓			✓	✓			
TruBolt™ Anchor Xtrem™	✓	✓	✓		✓	✓			✓	✓			
TruBolt™ Anchor	✓	✓	✓		✓	✓			✓	✓			
AnkaScrew™ Xtrem™	✓	✓	✓		✓	✓			✓	✓			
WERCS AnkaScrew™ Screw-In Anchor	✓	✓		✓	✓	✓			✓	✓			
DynaBolt™ Plus Anchor	✓	✓	✓		✓	✓	✓		✓	✓		✓	Stainless Steel
DynaBolt™ Plus Anchor Hex Bolt		✓		✓	✓	✓			✓	✓			
DynaSet™ Drop-In Anchor	✓	✓	✓			✓	✓		✓	✓		✓	Stainless Steel
RamPlug™ Anchor		✓		✓	✓	✓	✓		✓		✓		
ChemSet™ Reo 502™ PLUS Injection & Stud	✓	✓	✓	✓			✓	✓	✓	✓		✓	Stainless Steel
ChemSet™ Reo 502™ PLUS Injection & Thr'd Insert	✓	✓					✓		✓	✓			
ChemSet™ Reo 502™ PLUS Injection & Rebar	✓	✓	✓	✓			✓	✓	✓	✓			
EPCON™ C8 Xtrem™ Injection & Stud	✓	✓	✓				✓	✓	✓	✓		✓	Stainless Steel
EPCON™ C8 Xtrem™ Injection & Rebar	✓	✓	✓				✓	✓	✓	✓			
EPCON™ C6 PLUS Injection & Stud	✓	✓	✓	✓			✓	✓	✓	✓			
EPCON™ C6 PLUS Injection & Threaded Insert	✓	✓					✓		✓	✓			
EPCON™ C6 PLUS Injection & Rebar	✓	✓	✓	✓			✓	✓	✓	✓			
ChemSet™ 801 Xtrem™ XC² Injection & Stud	✓	✓	✓	✓			✓	✓	✓	✓		✓	Stainless Steel
ChemSet™ 801 Xtrem™ XC² Injection & Thr'd Insert	✓	✓					✓		✓	✓			
ChemSet™ 801 Xtrem™ XC² Injection & Rebar	✓	✓	✓	✓			✓	✓	✓	✓			
ChemSet™ 101 PLUS Injection & Stud	✓	✓	✓				✓	✓	✓	✓			
ChemSet™ Maxima™ Spin Capsule & Stud	✓	✓	✓				✓	✓					

INSTALLATION RELATED SYMBOLS

Indicates the suitable positioning and other installation related requirements.

- | | | | |
|--|--|--|---|
| | Suitable for floor applications. | | Anchors suitable for use in dry holes. |
| | Suitable for wall applications. | | Anchors suitable for use in damp holes. |
| | Suitable for overhead applications. | | Anchors suitable for use in holes filled with water. |
| | Suitable for hollow brick/block and hollow core concrete applications. | | Suitable for use in drilled holes. |
| | Anchor can be through fixed into substrate using fixture as template. | | Suitable for use in cored holes. |
| | Suitable for AAC and lightweight concrete applications. | | Suitable for contact with drinking water for human consumption. |

LEGEND ✓ = Recommended

Chemical Resistance

GUIDE

Anchor Selection Guide

Resistance of anchors exposed to:

Chemical Environment	Concentration	Adhesives						Fixings		
		ChemSet™ 101 PLUS	EPCON™ C8 Xtrem™	ChemSet™ 801 Xtrem™ XC²	Reo 502™ PLUS	Maxima™	EPCON™ C6 PLUS	SS	Gal	Zinc
Acetic Acid Aqueous Solution	10%	✓	✓	✓	✓	-	✓	✓	✗	✗
Acetic Acid Glacial	100%	✗		✗	-		-	-	✗	✗
Acetone	100%	✗	✗	✗	✗	✗	✗	-	-	-
Ammonia	100%	-	-	-	-	✓	-	✓	✗	✗
Ammonium Hydroxide	5%		-	✓	-	-	-	-	-	-
Ammonium Hydroxide	9%	-	✓ (10%)	-	-	-	-	-	-	-
Aniline	100%	-	-	-	-	✗	-	-	-	-
Aqueous Solution Aluminium Chloride	Saturated	✓	-	✓	✓		✓	-	-	-
Aqueous Solution Aluminium Nitrate	10%	✓	-	✓	✓		✓	-	-	-
Beer	100%	-	-	-	-	✓	-	✓	✗	✗
Benzene	100%	✗	-	✗	C	✗	C	✓	-	-
Benzoic Acid	Saturated	✓	-	✓	✓	-	✓	-	-	-
Benzyl Alcohol	100%	✗	-	✗	✗	-	✗	-	-	-
Butyl Alcohol	100%	C	-	C	C	-	C	-	-	-
Butyl Lactic Acid	100%	-	-	-	-	✗	-	-	-	-
Calcium Sulphate Aqueous Solution	Saturated	✓	-	✓	✓	-	✓	-	-	-
Carbon Dioxide	100%	-	-	-	-	✓	-	✓	-	-
Carbon Monoxide	Gas	✓	-	✓	✓	✓	✓	✓	-	-
Carbon Tetrachloride	100%	C	-	C	C	-	C	✓	-	-
Caustic Soda	20%	-	-	-	-	-	-	-	-	-
Cement in suspension	Saturated	-	-	-	-	✓	-	✓	-	-
Chlorine Water	Saturated	✗	-	✓	✗	-	✗	✓	-	-
Chloro Benzene	100%	✗	-	✗	✗	-	✗	-	-	-
Citric Acid Aqueous Solution	Saturated	✓	-	✓	✓	-	✓	-	✗	✗
Cyclohexanol	100%	✓	-	✓	✓	-	✓	-	-	-
Diesel fuel	100%	C	-	✓	C	-	C	✓	-	-
Diethylene Glycol	100%	✓	-	✓	✓	-	✓	-	-	-
Ethanol	95%	✗	-	C	✗	-	✗	-	-	-
Ethanol Aqueous Solution	20%	C	-	C	C	✗	C	✓	-	-
Ethanol Aqueous Solution	15%	-	-	-	-	✓	-	✓	-	-
Ethyl Acetate	100%	-	-	-	-	✗	-	✓	-	-
Ethylene Glycol	100%	-	-	-	-	✓	-	-	-	-
Heptane	100%	C	-	✓	C	✓	C	✓	-	-
Hexane	100%	C	-	C	C	✓	C	-	-	-
Hydrochloric Acid	4%	✓	✓ (10%)	✓	✓ (10%)	-	✓ (10%)	-	✗	✗
Hydrochloric Acid	15%	✓	-	✓	✓	-	✓	-	✗	✗
Hydrochloric Acid	25%	C	-	C	C	-	C	-	✗	✗
Hydrogen Fluoride	20%	-	-	-	-	✓	-	-	✗	✗
Hydrogen Peroxide (Bleach)	5%	-	-	-	-	✓	-	-	✗	✗
Hydrogen Peroxide (Bleach)	40%	-	-	-	-	✓	-	-	✗	✗
Hydrogen Sulphide Gas	100%	✓	-	✓	✓	-	✓	-	-	-
Isopropyl Alcohol	100%	✗	-	C	✗	-	✗	✓	-	-
Jet Fuel	100%	✗	-	✓	C	-	C	-	-	-
Linseed Oil	100%	✓	-	✓	✓	-	✓	✓	✗	✗
Lubricating Oil	100%	✓	✓	✓	✓	-	✓	✓	-	-
Methanol	15%	-	✗	-	-	✓	-	✓	✗	✗
Methanol	100%	-	✗	-	-	✗	-	✓	-	-
Methylene Chloride	100%	-	-	-	-	-	-	-	-	-
Mineral Oil	100%	✓	-	✓	✓	-	✓	✓	-	-

LEGEND

✓	= Retains 80% of properties when exposed up to 75°C
✗	= Not Resistant
C	= Occasional contact up to 25°C
-	= Information not available at time of publication

Chemical Resistance

GUIDE

Resistance of anchors exposed to:

Chemical Environment	Concentration	Adhesives						Fixings		
		ChemSet™ 101 PLUS	EPCON™ C8 Xtrem™	ChemSet™ 801 Xtrem™ XC²	Reo 502™ PLUS	Maxima™	EPCON™ C6 PLUS	SS	Gal	Zinc
Nitric Acid	< 20%	-	✓ (10%)	-	-	✓	-	✓	X	X
Nitric Acid	20 - 70%	-	-	-	-	✓	-	-	X	X
Parafin / Kerosene (Domestic)	100%	C	-	✓	C	-	C	-	-	-
Perchloroethylene	100%	-	-	-	-	✓	-	✓	-	-
Petroleum	100%	-	✓	-	-	✓	-	✓	X	X
Phenol Aqueous Solution	1%	X	-	X	C	-	C	✓	X	X
Phenol Aqueous Solution	100%	X	-	X	-	X	-	-	X	X
Phosphoric Acid	9%	✓	-	✓	-	✓	-	-	X	X
Phosphoric Acid	50%	✓	-	✓	✓	-	✓	-	X	X
Potassium Hydroxide (Caustic Potash)	10% / pH 13	C	-	C	✓	-	✓	✓	-	-
Potassium Hydroxide (Caustic Potash)	100%	-	-	-	-	✓	-	-	-	-
Sea Water	100%	✓	✓	✓	C	-	C	✓	X	X
Sodium Hydroxide	20%	-	✓ (50%)	-	-	-	-	-	-	-
Sodium Hypochlorite Solution	5 - 15%	✓	✓ (10%)	C	✓	-	✓	-	-	-
Styrene	100%	X	-	X	C	-	C	-	-	-
Sulphur Dioxide (40°C)	5%	✓	-	✓	✓	-	✓	-	-	-
Sulphur Dioxide Solution	10%	✓	-	✓	✓	-	✓	-	-	-
Sulphuric Acid	10%	✓	✓	✓	✓	✓	✓	✓	X	X
Sulphuric Acid	30%	✓	-	✓	✓	✓	✓	-	X	X
Sulphuric Acid	50%	✓	-	✓	✓	-	✓	-	X	X
Suphurous Acid	100%	-	✓	-	-	✓	-	-	X	X
Toluene	100%	-	-	-	-	X	-	✓	-	-
Turpentine	100%	C	-	C	C	-	C	✓	-	-
Washing Powder	100%	-	✓ (10%)	-	-	✓	-	✓	X	X
Water	100%	✓	-	✓	-	-	-	✓	X	X
White Spirit	100%	✓	-	✓	✓	-	✓	-	-	-
Xylene	100%	X	-	X	C	X	C	✓	X	X

LEGEND

✓ = Retains 80% of properties when exposed up to 75°C
X = Not Resistant
C = Occasional contact up to 25°C
- = Information not available at time of publication

Engineering Properties - Chemical Adhesives

Properties	Chemical Injection Adhesives				
	ChemSet™ 101 PLUS	EPCON™ C8 Xtrem™	ChemSet™ 801 Xtrem™	Reo 502™ PLUS	EPCON™ C6 PLUS
Appearance	Part A: White	Part A: White	Part A: White	Part A: White	Part A: White
	Part B: Black	Part B: Black	Part B: Black	Part B: Black	Part B: Black
	Mixed: Grey	Mixed: Grey	Mixed: Grey	Mixed: Grey	Mixed: Grey
Compressive Strength (MPa)* (after 7 days)	70	115**	62	95	95
Electrical resistivity	-	5x10 ¹⁵ Ω.cm	2x10 ¹¹ Ω.cm	378 V/mil***	378 V/mil***

* Compressive Strength test standard used - ASTM D 695 @ 20°C

** EPCON C8 achieves Compressive Strength after 48 hours in accordance with test standard NF EN ISO 604

***Reo502™ PLUS and EPCON™ C6 PLUS values are dielectric strength

Derivation of Capacity

ANCHORING TECHNOLOGY

[Back to index](#)

Anchoring Technology



DERIVATION OF CAPACITY

Internationally, design standards are becoming more probabilistic in nature and require sound Engineering assessment of both load case information and component capacity data to ensure safety as well as economy.

Published capacity data for **Ramset** Fasteners anchoring products are derived from **Characteristic Ultimate Capacities**.

From a series of controlled performance tests, Ultimate Failure Loads are established for a product.

Obviously, the value obtained in each test will vary slightly, and after obtaining a sufficient quantity of test samples, the Ultimate Failure Loads are able to be plotted on a chart.

Test values will typically centre about a mean value.

Once the mean Failure Load is established, a statistically sound derivation is carried out to establish the Characteristic Ultimate Capacity which allows for the variance in results as well as mean values.

The Characteristic Value chosen is that which ensures that a 90% confidence is obtained that 95% of all test results will fall above this value.

From this value, and dependent on local design requirements, the design professional may then undertake either a strength limit state or working load design assessment of the application at hand, confident that they are working with state of the art capacity information.

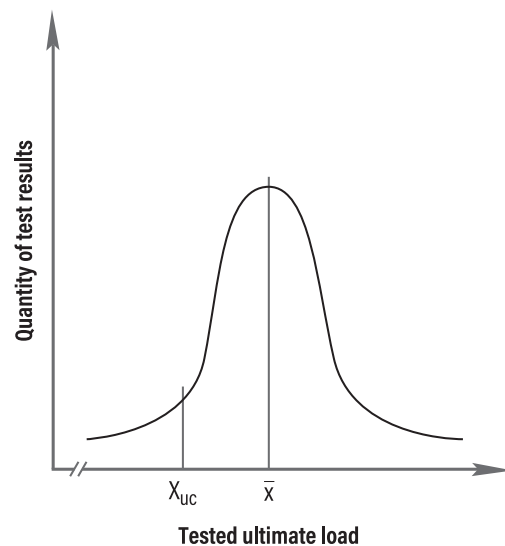

\bar{x} = Mean Ultimate Capacity
 X_{uc} = Characteristic Ultimate Capacity

Anchoring Principles

ANCHORING TECHNOLOGY

GENERAL

Ramset anchors are high quality, precision made fastenings secured with either a torque induced setting action, a displacement induced setting action or a chemical bonding action.

Resistance to tensile loads is provided by mechanisms which depend upon the type of anchor and its method of setting. Information on the elements that comprise the resistance mechanisms is given separately for each type of anchor.

Generally, shear load resistance mechanisms are more uniform amongst anchors, and comprise these elements:

- the bolt or stud, and in some cases, the steel spacer of the anchor.
- the ability of the anchor to resist the bending moment induced by the shear force.
- the compressive strength of the concrete.
- the shear and tensile strength of the concrete at the surface of the potential concrete failure wedge.

When loaded to failure in concrete shear, an anchor located near an edge breaks a triangular wedge away from the concrete.

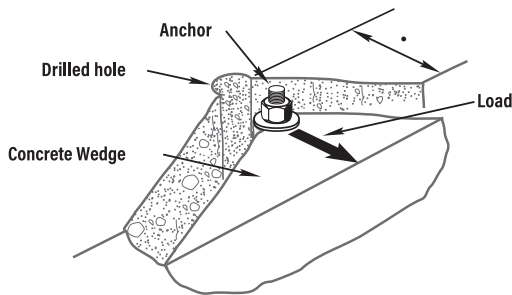

CONCRETE WEDGE FAILURE MODE

TORQUE SETTING ANCHORS

SpaTec Xtrem™, TruBolt™, and DynaBolt Plus anchors are inserted through the hole in the fixture, into a hole drilled into the concrete, and are set by the application of assembly torque to the nut or bolt head.

The diameter of the drilled hole is slightly larger than the outer diameter of the anchor. When torque is applied to the bolt head or nut of the anchor, the cone is drawn up into the sleeve to expand its effective diameter. The wedge action of the cone nut in the sleeve increases with increasing torque. The reaction of the concrete against the expanded sleeve of the anchor creates a high friction force between the anchor and the wall of the drilled hole. The body of the concrete contains and restricts the expansion forces. The application of assembly torque produces a preload between the fixture and the concrete.

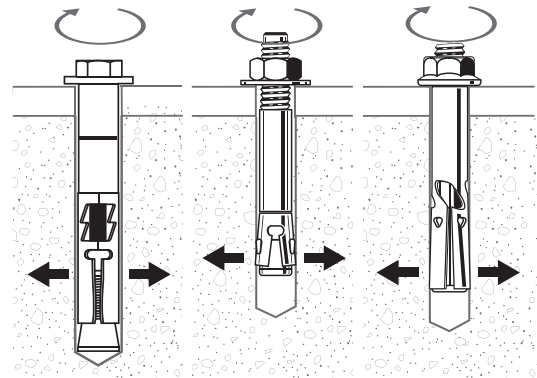

TORQUE SETTING ACTION
SpaTec Xtrem™, TruBolt™ & DynaBolt Plus Anchors

If increasing load were to be applied to the fixture, preload would reduce and finally be removed. At this point, the steel cone would begin to be drawn further into the expansion sleeve. When loaded to failure in concrete tension, the failure mode of a correctly installed anchor is characterised by the formation of a concrete cone, the apex of which is located at the effective depth of the anchor.

Alternatively, if the tensile capacity of the steel is exceeded, the anchor will break.

Anchoring Principles

ANCHORING TECHNOLOGY

Anchoring Technology

TORQUE SETTING ANCHORS cont.

Effective depth is the effective length, L_e of the anchor less the fixture thickness, t .

$$h = L_e - t$$

Note that for the purpose of calculating "h", the fixture thickness "t" should include the thickness of non structural grout, packing, etc.

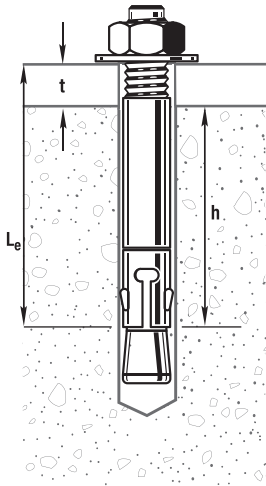

Applied tensile loads are resisted by these elements:

- the anchor bolt or stud.
- the wedge action of the steel cone in the sleeve.
- friction between the expanded sleeve and the drilled hole.
- shear and tension at the surface of the potential concrete cone.

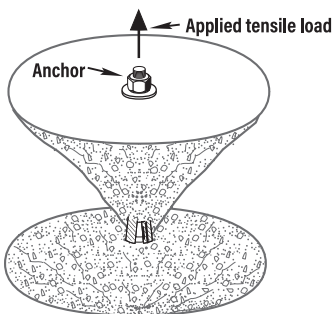

CONCRETE CONE FAILURE MODE

ROTATION SETTING ANCHORS

The Boa® Coil anchor is set by driving the anchor into the hole with a hammer up to the "depth set" mark and then, using a spanner or wrench, rotating the bolt through the coil, thereby setting the anchor.

The diameter of the drilled hole is a similar size to that of the anchor.

Resistance to tensile load is provided by the two (2) components which make up the Boa® Coil anchor, the "bolt" and the "coil".

The reaction of the concrete against the expanded anchor creates a high friction force and an undercut forms between the anchor and the hole wall. The body of the concrete contains and restricts the expansion forces. The action of tightening the anchor bolt against the fixture produces a preload between the fixture and the concrete.

As the applied tensile load increases, a commensurate decrease in preload occurs, until at some point after all preload has been removed, first slip occurs.

Concrete is locally crushed around the coil as it beds in further, accompanied by an increase in load capacity.

When failure occurs in the concrete the mode of failure is a broaching effect whereby load is still being held until the applied load is equivalent to the shear and tensile capacity of the concrete, at this point a cone of failure occurs.

Anchoring Principles

ANCHORING TECHNOLOGY

DISPLACEMENT SETTING ANCHORS

DynaSet anchors are inserted into a drilled hole, and set by the displacement of the expander plug.

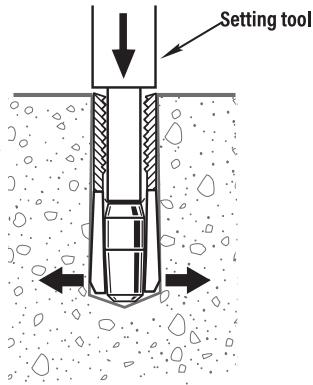

DISPLACEMENT SETTING DYNASET™ ANCHORS

The diameter of the drilled hole is slightly larger than the outer diameter of the anchor. When the expander plug is fully driven home (displaced), it expands the lower portion of the anchor body, to increase its effective diameter. Because the anchor is expanded by a series of blows from a setting punch, a certain amount of shock loading is imparted to the concrete immediately adjacent. The reaction of the concrete against the expanded body of the anchor creates a high friction force between the anchor and the wall of the drilled hole. The body of the concrete contains and restricts the expansion forces.

A bolt is subsequently screwed into the anchor.

The mode of failure in concrete tension is characterised by the formation of a shear cone, the apex of which is located at the effective depth of the anchor.

Applied tensile loads are resisted by the following elements:

- the bolt.
- the steel annulus of the anchor.
- friction between the expanded anchor and the drilled hole.
- shear and tension at the surface of the potential concrete cone.

CHEMICAL ANCHORS

ChemSet Injection Systems, ChemSet Maxima Spin Capsules, anchors are set in a drilled hole by the hardening of the chemical adhesive.

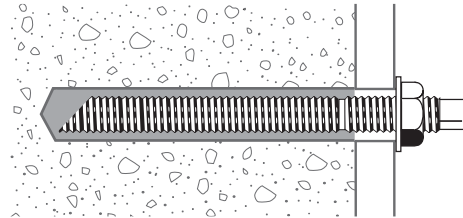

CHEMICAL ANCHORING

The adhesive penetrates the pores and irregularities of the base material and forms a key around the threads of the stud. The cured adhesive becomes a hard, strong material that transfers load to the base material via mechanical and adhesive bonds with the surface of the drilled hole.

When tested to failure, a shallow concrete cone may form at the top of the anchor. This cone does not necessarily contribute to the tensile strength of the anchor, but simply registers the depth at which the concrete cone strength happens to equate to the cumulative bond strength of the adhesive to the sides of the hole. For a given concrete strength, the stronger the adhesive bond, the deeper the cone.

Applied tensile loads are resisted by:

- the stud.
- bond between the stud and the adhesive shear in the adhesive bond between the adhesive and the concrete.
- shear and tension in the concrete.

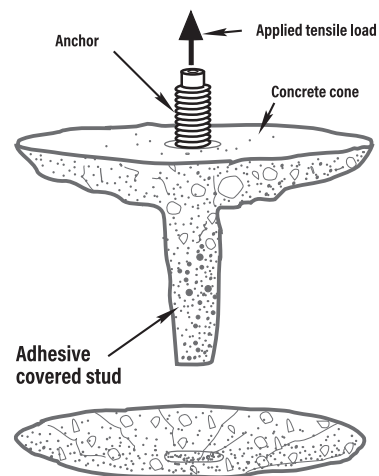

CONCRETE BOND FAILURE MODE

Base Materials

ANCHORING TECHNOLOGY

SUITABILITY

Ramset anchors can be used in plain or in reinforced concrete.

It is recommended that the cutting of reinforcement be avoided. The specified characteristic compressive strength " f_c " will not automatically be appropriate at the particular location of the anchor. The designer should assess the strength of the concrete at the location of the anchor making due allowance for degree of compaction, age of the concrete, and curing conditions.

Particular care should be taken in assessing strength near edges and corners, because of the increased risk of poor compaction and curing. Where the anchor is to be placed effectively in the cover zone of closely spaced reinforcement, the designer should take account of the risk of separation under load of the cover concrete from the reinforcement.

Concrete strength " f_c " determined by standard cylinders, is used directly in the equations.

The design engineer is responsible for the overall design and dimensioning of the structural element to resist the service loads applied to it by the anchor.

Where structural base materials are covered with a non-structural material such as plaster or render, anchors should be embedded to the design depth in the structural base material. Allowance must be made for the thickness of the non-structural material when considering the application of shear loads, and in determining the moment arm of applied bending moments.

In hollow block masonry, where the cores are filled with concrete grout, **Ramset** anchors may be designed and specified similarly as in concrete, provided the designer assesses the effective strength of the masonry including the joints.

However, it is not advisable to use certain heavy duty anchors in unfilled hollow masonry units (either bricks or blocks).

These heavy duty anchors include all SpaTec Xtrem[™], TruBolt[™] and ChemSet capsule anchors, and DynaBolt Plus, Boa[™] Coil anchor, DynaSet[™], and Chemical Injection anchors greater than M12 in diameter. In any case the designer should assess the effective strength of the masonry including the joints, and determine how the loading is to be transferred to the masonry structure. Load tests should be conducted on site to assist in assessing masonry strength.

Ramset heavy and medium duty anchors are not recommended for low strength base materials such as autoclaved aerated concrete, except for ChemSet Injection System studs up to M12.

Base Materials

ANCHORING TECHNOLOGY

ABSOLUTE MINIMUM DIMENSIONS

Spacings, edge distances, and concrete thicknesses are limited to absolute minima, in order to avoid risks of splitting or spalling of the concrete during the setting of **Ramset** torque, rotation and displacement setting anchors. Absolute minima for stress-free anchorages such as chemical anchors are defined on the basis of notional limits, which take account of the practicalities of anchor placement.

Absolute minimum spacing " a_m " and absolute minimum edge distance " e_m ", define prohibited zones where no anchor should be placed. The prohibited spacing zone around an anchor has a radius equal to the absolute minimum spacing. The prohibited zone at an edge has a width equal to the absolute minimum edge distance.

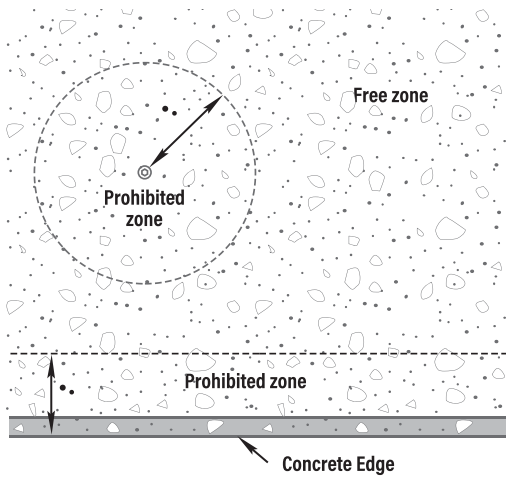

PROHIBITED ZONES FOR SPACINGS AND EDGES

Where an expansion anchor is placed at a corner, there is less resistance to splitting, because of the smaller bulk of concrete around the anchor. In order to protect the concrete, the minimum distance from one of the edges is increased to twice the absolute minimum.

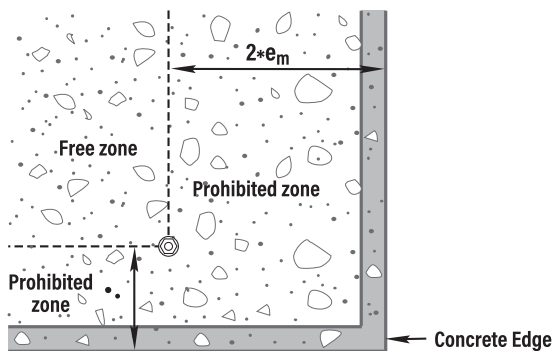

PROHIBITED ZONES AT CORNER FOR EXPANSION ANCHORS

The concrete thickness minima given below, does not include concrete cover requirements, and are not a guide to the structural dimensions of the element. It is the responsibility of the design engineer to proportion and reinforce the structural element to carry the loads and moments applied to it by the anchorage, and to ensure that the appropriate cover is obtained.

In order to avoid 'breakthrough' during drilling of the hole into which anchors will be installed, maintain a cover value to the base of the hole equal to $2x$ the drilled hole diameter, d_h , ie. for a hole of 20mm diameter allow 40mm cover to the rear face of the substrate component.

In certain circumstances, it may be possible to install anchors in thinner concrete elements. If cover to the anchor is not required, and a degree of spalling can be tolerated between the end of the expansion sleeve and the far surface of the concrete, embedment close to the far surface may be feasible. More information on the conditions for reduced concrete thickness may be obtained from **Ramset** Engineers.

Where an anchor is installed at the absolute minimum edge distance " e_m ", substrate thickness must be a minimum of $2 * h$.

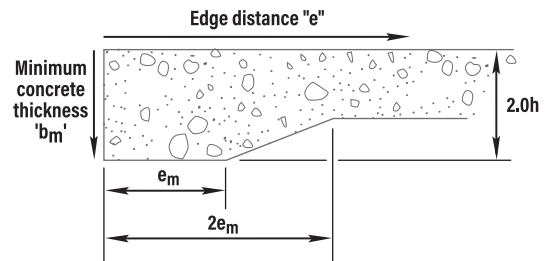

CONCRETE THICKNESS

Design

ANCHORING TECHNOLOGY

WORKING LOAD DESIGN

Using the permissible stress method which is still valid in many design situations:

$$L \text{ (applied load)} \leq R_a \text{ (working load limit capacity)}$$

Working load limits are derived from characteristic ultimate capacities and factor of safety:

$$R_a = R_u / F_s$$

Factors of safety are related to the mode of failure, and material type, and the following are considered appropriate for structural anchoring designs:

$$f_{ss} = \text{factor of safety for steel in tension and bending} \\ = 2.2$$

$$f_{sv} = \text{factor of safety for steel in shear} \\ = 2.5$$

$$f_{sc} = \text{factor of safety for concrete} \\ = 3.0$$

STRENGTH LIMIT STATE DESIGN

Designers are advised to adopt the limit state design approach which takes account of stability, strength, serviceability, durability, fire resistance and any other requirements in determining the suitability of the fixing. Explanations of this approach are found in the design standards for structural steel and concrete. When designing for strength the anchor is to comply with the following:

$$\phi R_u \geq S^*$$

where:

$$\phi = \text{capacity reduction factor}$$

$$R_u = \text{characteristic ultimate load carrying capacity}$$

$$S^* = \text{design action effect}$$

$$\phi R_u = \text{design strength}$$

Design action effects are the forces, moments, and other effects, produced by agents such as loads, which act on a structure. They include axial forces (N^*), shear forces (V^*), and moments (M^*), which are established from the appropriate combinations of factored loads as detailed in the **AS-NZS1170** "Minimum Design Load on Structures" series of Australian/New Zealand Standards and **NZS 4203** series of New Zealand Standards.

Capacity reduction factors are given below, these typically comply with those detailed in **AS4100** - "Steel Structures", **AS3600 & NZS3101** - "Concrete Structures" & **AS5216** - "Design of Post-installed and cast-in fastenings in concrete". The following capacity reduction factors are considered typical:

$$\phi_c = \text{capacity reduction factor, concrete tension} \\ = 1/1.5 = 0.67$$

$$\phi_q = \text{capacity reduction factor, concrete shear} \\ = 1/1.5 = 0.67$$

$$\phi_n = \text{capacity reduction factor, steel tension} \\ = 1/1.4 = 0.67$$

$$\phi_v = \text{capacity reduction factor, steel shear} \\ = 1/1.5 = 0.67 \text{ or } 1/1.25 = 0.8$$

$$\phi_m = \text{capacity reduction factor, steel bending} \\ = 1/1.25 = 0.8$$

Whilst these values are used throughout this document, other values may be used by making the adjustment for ϕ as required.

Tension

ANCHORING TECHNOLOGY

STEEL TENSION

The characteristic ultimate tensile capacity for the steel of an anchor is obtained from:

$$N_{US} = A_s f_u$$

where:

$$N_{US} = \text{characteristic ultimate steel tensile capacity} \quad (\text{N})$$

$$A_s = \begin{matrix} \text{tensile area} & (\text{mm}^2) \\ \text{stress area for threaded sections} & (\text{mm}^2) \end{matrix}$$

$$f_u = \text{characteristic ultimate tensile strength} \quad (\text{MPa})$$

The tensile working load limit (permissible stress method) for the steel of a **Ramset** anchor is obtained from:

$$N_{as} = N_{US} / 2.2$$

CONCRETE CONE

Characteristic ultimate tensile capacities for mechanical anchors vary in a predictable manner with the relationship between:

- hole diameter (d_h)
- effective depth (h), and
- concrete compressive strength (f'_c)

within a limited range of effective depths, h .

This is typically expressed by a formula such as:

$$N_{uc} = k_1 \sqrt{f'_c} h^{1.5}$$

where k_1 is the factor for concrete condition (cracked or un-cracked)

Anchors may have constraints that apply to the effective depth of the anchor or the maximum or minimum concrete strength applicable.

Anchor effective depth (h) is taken from the surface of the substrate to the point where the concrete cone is generated. In establishing the effective depth for mechanical anchors, the designer should allow for any gap expected to exist between the fixture and the concrete prior to clamping down.

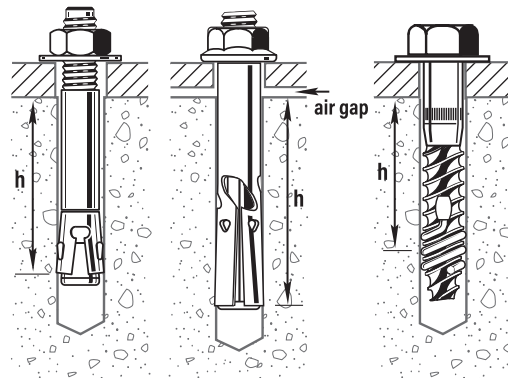

EFFECTIVE DEPTH FOR ANCHORS

The appropriate concrete compressive strength " f'_c " is the actual strength at the location of the anchor, making due allowance for site conditions, such as degree of compaction, age of concrete, and curing method.

Concrete tensile working load limits (permissible stress method) for anchors are obtained from:

$$N_{ac} = N_{uc} / 3.0$$

Tension

ANCHORING TECHNOLOGY

Anchoring Technology

PULL-THROUGH

This mode of failure occurs in expansion anchors under tensile loading, where the applied load exceeds the frictional resistance between either the cone and the expansion sleeve, or the sleeve and the sides of the drilled hole in the concrete. Failures of this type are often associated with anchors that are improperly set, or used in larger diameter holes drilled into the concrete with over-sized drill bits.

The load carrying capacities of anchors with thick-walled expansion sleeves such as SpaTec Xtrem™ and correctly set DynaSet anchors, are not sensitive to this mode of failure.

The recommended limits on concrete strength “ f_c ” in the determination of concrete cone strength for DynaBolt® and TruBolt® anchors, act as a precaution against this mode of failure.

CONCRETE BOND

Chemical Anchors

Characteristic ultimate tensile load carrying capacities for concrete bond failure in the compression zone varies with hole depth, effective depth and concrete strength in a similar manner to concrete cone failure in mechanical anchors.

Effective anchor depth “ h ” is taken from the start of the adhesive, (usually the surface of the concrete) to the bottom of the stud. For chemical capsule anchors, it is not usual to deviate from the depths given in the Section Properties and Data. Whilst it is essential to provide sufficient resin to fill the space between the stud and the concrete, the installer must avoid excessive overspill. Hole depths for capsule anchors may be increased in increments related to the volume of capsules available. It is recommended to seek advice from **Ramset** Technical Staff before deviating from the recommended hole depths or hole diameters.

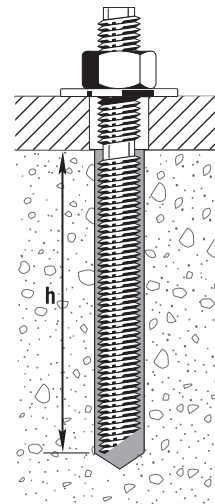

EFFECTIVE DEPTH FOR CHEMICAL ANCHORS

The appropriate concrete strength “ f_c ” to be used in these equations, is the actual strength at the location of the anchor, making due allowance for site conditions, such as degree of compaction, age of concrete, and curing method.

Concrete tensile working load limits (permissible stress method) for **Ramset** chemical anchors are obtained from:

$$N_{ac} = N_{uc} / 3.0$$

Tension

ANCHORING TECHNOLOGY

CRITICAL SPACING

In a group of mechanical anchors loaded in tension, the spacing at which the cone shaped zones of concrete failure just begin to overlap at the surface of the concrete, is termed the critical spacing, a_c .

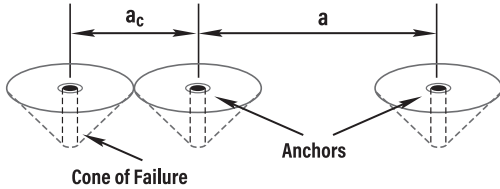

For chemical anchors the critical spacing is determined by interference between the cylindrically shaped zones of stress surrounding the anchors.

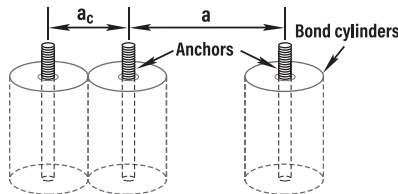

At the critical spacing, the capacity of one anchor is on the point of being reduced by the zone of influence of the other anchor. **Ramset** anchors placed at or greater than critical spacings are able to develop their full tensile capacity, as limited by concrete cone or concrete bond capacity. Anchors at spacings less than critical are subject to reduction in allowable concrete tensile capacity.

Both ultimate and working loads on anchors spaced between the critical and the absolute minimum, are subject to a reduction factor " X_{na} ", the value of which depends upon the position of the anchor within the row:

$$N_{ucr} = X_{na} * N_{uc}$$

for strength limit state design.

And, for permissible stress method analysis:

$$N_{ar} = X_{na} * N_{ac}$$

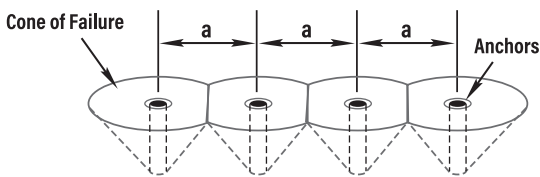

ANCHORS IN A ROW

For anchors influenced by the cones of two other anchors, as a result for example, of location internal to a row:

$$X_{na} = a / a_c \leq 1$$

Unequal distances (" a_1 " and " a_2 ", both $< a_c$ ") from two adjacent anchors, are averaged for an anchor internal to a row:

$$X_{na} = 0.5 (a_1 + a_2) / a_c$$

If the anchors are at the ends of a row, each influenced by the cone of only one other anchor:

$$X_{na} = 0.5 (1 + a/a_c) \leq 1$$

The cone of anchor A is influenced by the cones of anchors B and C, but not additionally by the cone of anchor D. " X_{na} " is the appropriate reduction factor as a conservative solution.

Critical spacing (a_c) defines a critical zone around a given anchor, for the placement of further anchors. The critical spacing zone has a radius equal to the critical spacing. The concrete tensile strengths of anchors falling within the critical zone are reduced. For clarity, the figure includes the prohibited zone as well as the critical zone.

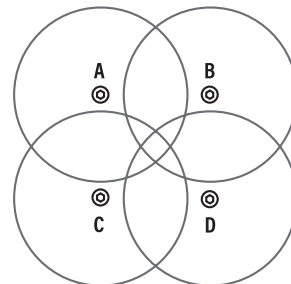

ANCHOR GROUP INTERACTION

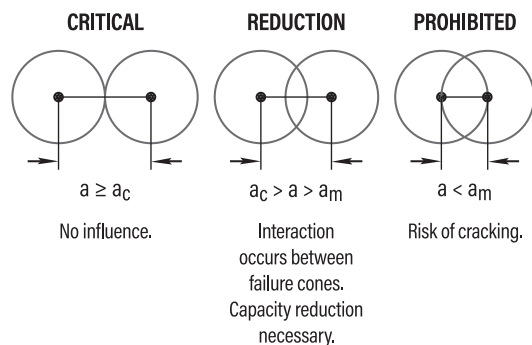

Tension

ANCHORING TECHNOLOGY

Anchoring Technology

CRITICAL EDGE DISTANCE

At the critical edge distance for anchors loaded in tension, reduction in tensile capacity just commences, due to interference of the edge with the zone of influence of the anchor.

Expansion Anchors

The critical edge distance (e_c) for expansion anchors is taken as one and a half times effective depth:

$$e_c = 1.5 * h$$

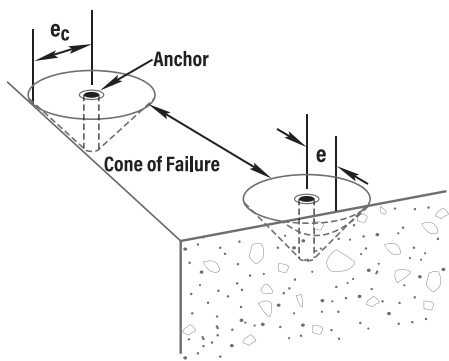

INTERFERENCE OF EDGE WITH CONCRETE CONES

Rotation Set Anchors

The critical edge distance for Boa Coil anchor is taken as:

$$e_c = 6 * d_b$$

Chemical and Screw In Anchors

For chemical and screw in anchors the critical edge distance is determined by interference between the edge and the cylindrically shaped zones of stress surrounding the anchors.

$$e_c = 1.5 * h \text{ (AUS/NZ/EUR design method)}$$

$$e_c = 4d_b \text{ (Ramset design method)}$$

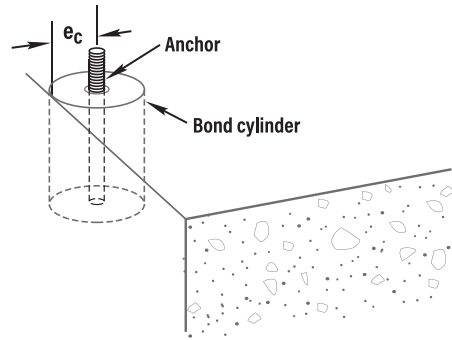

INTERFERENCE OF EDGE WITH BOND CYLINDER

If the edge lies between the critical and the absolute minimum distance from the anchor, the concrete tensile load reduction co-efficient " X_e ", is obtained from the following formula:

$$X_e = 0.3 + 0.7 * e / e_c \leq 1$$

Applies to $e_m \leq e \leq e_c$

where:

$$X_e = \text{edge reduction factor tension}$$

Critical edge distances define critical zones for the placement of anchors with respect to an edge. The critical edge zone has a width equal to the critical edge distance. The concrete tensile strengths of anchors falling within the critical zone are reduced. For clarity, the figure includes the prohibited zone as well as the critical zone.

Shear

ANCHORING TECHNOLOGY

ANCHOR STEEL SHEAR

For an anchor not located close to another anchor nor to a free concrete edge, the ultimate shear load will be determined by the steel shear strength of the anchor, provided the effective depth of the anchor is compliant with the following:

SpaTec™ Xtrem™

$$h \geq 4 * d_h$$

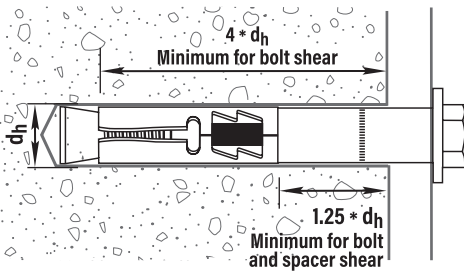

MINIMUM INSERTION FOR BOLT SHEAR

For SpaTec Plus it is required that the bottom end of the spacer is inserted at least one and a quarter times hole diameter ($1.25 * d_h$) in order for the shear strength of the spacer to be allowed as contributing to the shear strength of the anchor.

Boa Coil

For full bolt shear,

$$h \geq 6 * d_h$$

A reduced shear capacity is applicable down to a minimum value of $3 * d_h$

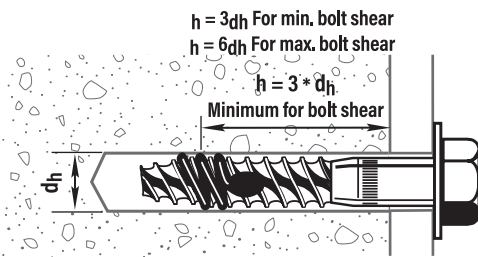

MINIMUM INSERTION FOR BOLT SHEAR

TruBolt™

$$h \geq 4 * d_h$$

DynaBolt™

$$h \geq 3.5 * d_h$$

DynaSet anchors are not normally embedded to four times the diameter of the drilled hole, and their characteristic shear capacities relate to the bending strength of the anchor or shear of the inserted bolt.

The designer should also take into account any conditions that may cause bending moments and unbalanced forces to be applied simultaneously. Any tendency of the fixture to lift away from the surface under load will generate moments and tension forces.

The characteristic ultimate shear capacity (V_{us}) for the steel of an anchor is obtained from:

$$V_{us} = 0.62 * A_s * f_u \quad (N)$$

CONCRETE EDGE SHEAR

Where load is directed either towards or parallel to an edge, and the anchor is located in the proximity of the edge, failure may occur in the concrete.

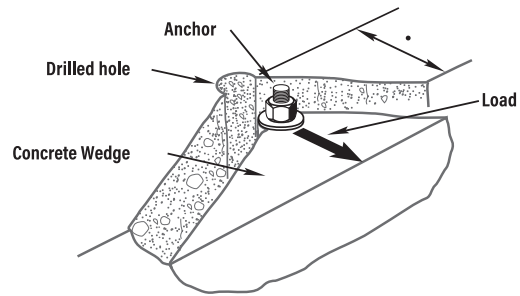

CONCRETE WEDGE FAILURE MODE

Shear

ANCHORING TECHNOLOGY

Anchoring Technology

SPACING UNDER CONCRETE SHEAR

At a spacing of at least 2.5 times edge distance, there is no interference between adjacent failure wedges. Where anchor spacing is less than 2.5 times edge distance, the shear load capacities in the concrete are subject to a reduction factor "X_{va}".

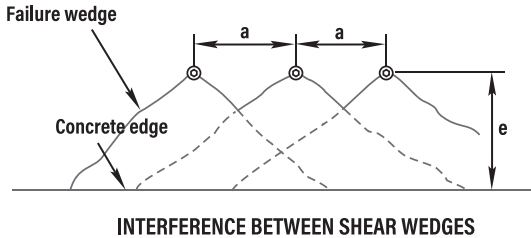

$$X_{va} = 0.5 (1 + a / (2.5 * e)) \leq 1$$

The direction of the shear load towards an edge will influence the concrete edge shear capacity. This is accounted for with the factor X_{vd}.

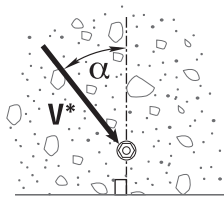

When a row of anchors is subject to a shear load acting towards an edge, the distribution of each anchor's capacity in the anchor group is derived by using the factor X_{vn}.

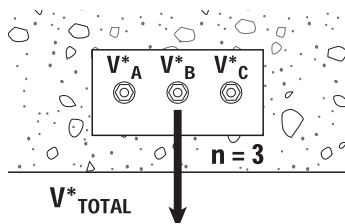

$$V^*_A = V^*_B = V^*_C$$

$$\phi V_{ur} \geq V^*_A, V^*_B, V^*_C$$

Two anchors installed on a line normal to the edge, and loaded in shear towards the edge, are treated as a special case. Where the anchors are loaded simultaneously by the same fixture, the ultimate or the concrete edge shear capacity for each anchor will be influenced by the other anchor. Where the spacing "a" between anchors A and B is less than or equal to "e_B" the edge distance of anchor B, the ultimate edge shear for anchor A is equal to anchor B, despite the longer edge distance of anchor A:

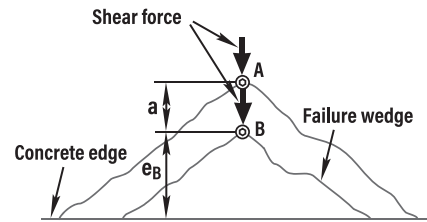

ANCHORS IN LINE TOWARDS AN EDGE

For an anchor located at a corner and where the second edge is parallel to the applied shear, interference by the second edge upon the shear wedge is taken into account by the following reduction factor:

$$X_{vs} = 0.30 + 0.56 * e_1 / e_2 \leq 1$$

An anchor is considered to be at a corner if the ratio of the edge distance parallel to the direction of shear to the edge distance in the direction of shear is less than 1.25.

If:

$\frac{e_1}{e_2} < 1.25$ then apply reduction factor X_{vs} shown above

$\frac{e_1}{e_2} > 1.25$ acceptable X_{vs} = 1.00

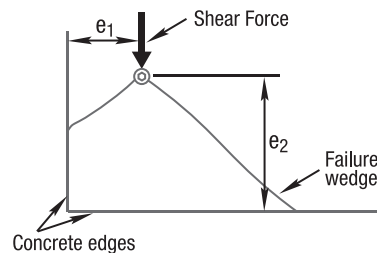

ANCHOR AT A CORNER

Bending

ANCHORING TECHNOLOGY

The designer must allow for bending, when an anchor is exposed to a shear force that will result in the anchor going into bending. For this to occur, the fixture plate must be free to rotate around the bolt as shown due to an air gap or non-structural material between the fixture and the concrete surface.

Where the anchor is part of an array of anchors that prevent the fixture from rotating, or if the gap is filled with grout, then bending cannot occur. Note: Where an incompressible layer such as grout is used, it does not contribute to the pullout capacity of the anchor, hence the layer thickness is to be added to the fixture thickness when calculating the anchor effective depth.

The designer's calculation of the design bending moment (M^*) should include an allowance in the moment arm of one hole diameter inwards from the face of the concrete:

$$M^* = V^* * (d_h + g + t / 2)$$

where:

- V^* = shear design action effect (N)
- g = gap between fixture and concrete surface (mm)
- t = fixture thickness (mm)
- d_h = drilled hole diameter (mm)

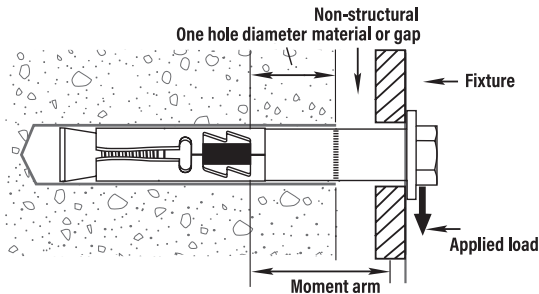

DESIGN BENDING MOMENT

Anchor moments need only be considered if there is a non-structural material or gap between the fixture and substrate that results in application of a moment to the anchor itself.

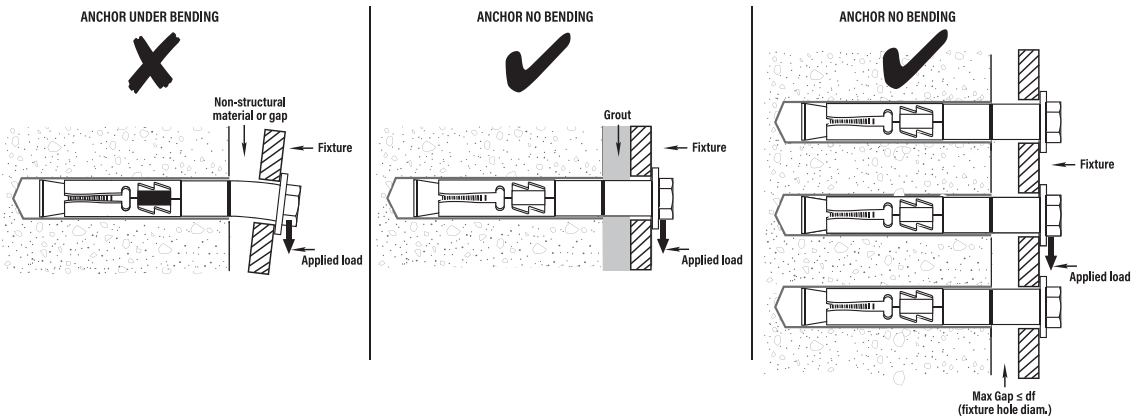

In the case of working load limit design, applied moments (M) are calculated as follows:

$$M = V * (d_h + g + t / 2)$$

$$V = \text{applied shear force (N)}$$

Characteristic ultimate bending capacities (M_u), are obtained from the following formula:

$$M_u = f_y * Z$$

where:

$$f_y = \text{characteristic yield strength (MPa)}$$

$$Z = \text{section modulus of the anchor (mm}^3\text{)}$$

and for working load limit bending moment (M_a):

$$M_a = M_u / f_{ss}$$

$$= M_u / 2.2$$

Combined Loading

ANCHORING TECHNOLOGY

TENSION AND BENDING

Where an anchor is subjected to combined tension and bending, ultimate tensile capacity for the steel is determined as follows:

$$N_{USR} = N_{US} * (1 - (M^* / \phi_m M_u))$$

where:

ϕ_m = capacity reduction factor, steel bending, recommended as 0.8

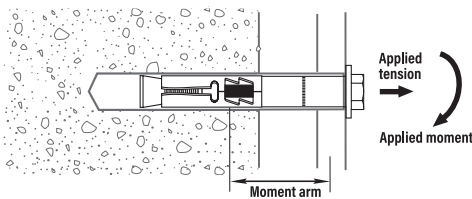

COMBINED TENSION, SHEAR AND BENDING

Factored working load limit steel tensile capacities, to allow for the effects of bending moments are given by:

$$N_{ASR} = N_{AS} * (1 - M / M_a)$$

where:

N_{ASR} = factored working load limit steel tensile capacity (N)

SHEAR AND BENDING

There is no reduction in shear capacity in the case of combined bending and shear. Shear capacity and bending capacity are checked independently.

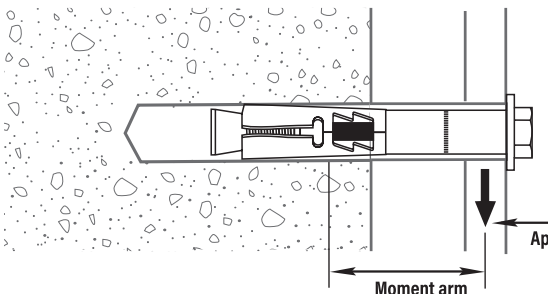

COMBINED TENSION AND SHEAR

TENSION AND SHEAR

Design for combined tension and shear, requires firstly the determination of anchor capacities. Strength limit state design capacities are taken as:

$$\phi N_{ur} = \phi_c N_{urc} \leq \phi_n N_{us}$$

$$\phi V_{ur} = \phi_q V_{ur} \leq \phi_v V_{us}$$

where:

ϕ = capacity reduction factor

ϕN_{ur} = design reduced ultimate tensile capacity

ϕV_{ur} = design reduced ultimate shear capacity

ϕ_c = capacity reduction factor concrete tension

ϕ_q = edge capacity reduction factor concrete shear, recommended as $1/1.5 = 0.67$

ϕ_n = capacity reduction factor, steel tension, recommended as $1/1.4 = 0.71$

ϕ_v = capacity reduction factor, steel shear, recommended as $1/1.5 = 0.67$

Working load capacities are determined as follows:

$$N_a = N_{ar} \leq N_{sr}$$

$$V_a = V_{ar} \leq V_{as}$$

where:

N_a = working load limit tensile capacity

V_a = working load limit shear capacity

Strength limit state combination of tension and shear complies with the following:

$$N^* / \phi N_{ur} \leq 1$$

$$V^* / \phi V_{ur} \leq 1$$

$$N^* / \phi N_{ur} + V^* / \phi V_{ur} \leq 1.2$$

The following formulae are used for working load combination:

$$N / N_a \leq 1$$

$$V / V_a \leq 1$$

$$N / N_a + V / V_a \leq 1.2$$

where:

N = applied tensile load

V = applied shear load

Anchor Groups

ANCHORING TECHNOLOGY

This information deals specifically with the design of individual anchors, loaded either as a single anchor or as a member of a group. Under the relevant loading condition, as a general principle, all load reduction factors applicable to an individual anchor in the group should be multiplied together to account for the combined effects on the anchor of multiple loads, group layout, and base material geometry. In the application of loads, due allowance should be made for eccentricities in the lines of action of loads relative to the centroid of the group, and for any other conditions likely to cause a magnification of load to an anchor, i.e. prying forces.

In a group loaded in shear there is a risk of uneven loading, particularly where more than two anchors are arranged one behind the other in the direction of the load. The designer should assess and make appropriate allowance for the ability of the fixture to distribute the load to anchors in the group.

The simplified strength limit state design process detailed in this document is intended to cover a wide range of applications.

It is suitable for verifying capacity of single anchors or groups of anchors, however it must be remembered that the capacity data given is PER ANCHOR and load cases must be distributed to all anchors in a group and each anchor verified as being suitable.

The simplified design process allows verification of:

Single anchors subject to shear and/or tension.

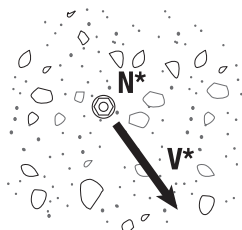

Groups of anchors (row, rectangular array etc.) subject to tensile loading and/or shear loading **not** towards an edge.

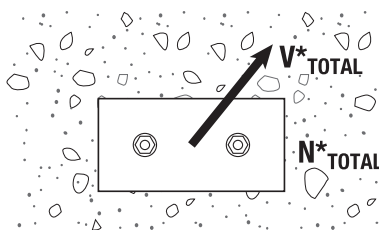

Groups of anchors subject to tensile and/or shear loading where the line of anchors parallel to (and closest to) the edge are considered to take the total shear load.

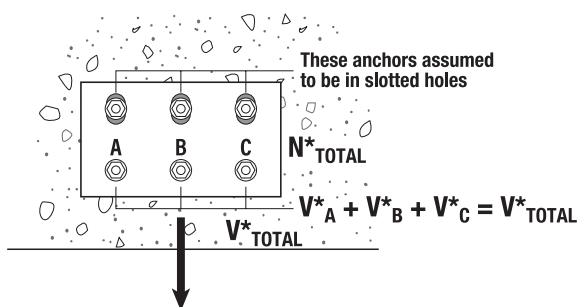

For a row of anchors subject to a shear force component towards an edge, the design tables assume that the design load case is evenly distributed to all anchors in the group and calculates the averaged shear capacity for each anchor.

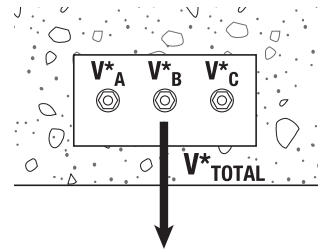

$$V^*_A = V^*_B = V^*_C$$

$$n = 3$$

$$\phi V_{ur} = \text{per anchor capacity}$$

The design tables are unable to verify capacity for anchors in the following configurations:

- Anchors subject to a moment.
- Anchors in a line towards an edge with a shear load component acting towards that edge, unless it is assumed that the anchor closest to the edge takes all of the shear load, V^*_{TOTAL}

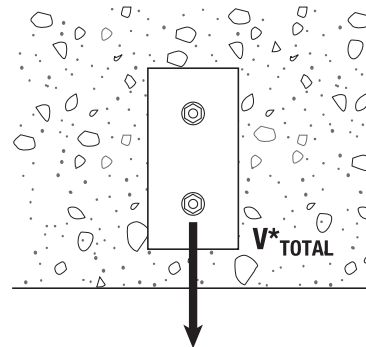

For these cases, please refer to the **Ramset** Anchor Design software or contact your local **Ramset** Engineer for advice.

Assembly Torque AND PRELOAD

Anchoring Technology

SLIP AND CYCLIC LOADING

The application of assembly torque to a well designed anchor, results in the generation of a preload or clamping force between the fixture and the concrete. Because the fixture supports the concrete and suppresses cone failure, preload may exceed concrete cone failure load. The concrete experiences an elastic compression beneath the fixture. Under external loading of the fixture, the surfaces of the joint will not separate until the applied load exceeds the preload. Although the magnitude of the preload influences the deformation of the fixing under load, it does not in general, affect the ultimate static load capacity of the fixing.

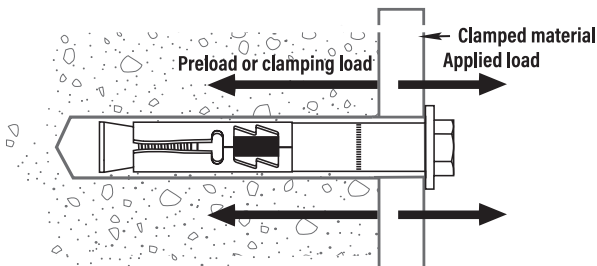

PRELOADING OF FIXTURE TO CONCRETE

Heavy and medium duty sleeve anchors with a fully functioning pull-down mechanism such as **Ramset** SpaTec Xtrem™ and DynaBolt Plus anchors, ensure that loss of preload to the spacer or sleeve is negligible, even where a substantial gap may have existed between the concrete and the fixture, due to unevenness in the mating surfaces. After the expansion sleeve has enlarged to grip the sides of the hole, the pull-down mechanism allows the gap to be closed and the fixture to be clamped against the concrete.

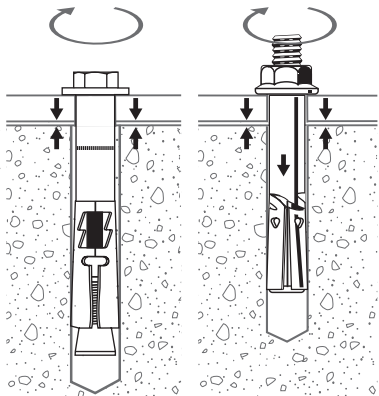

SpaTec™ Xtrem™ and DynaBolt™ Plus Anchors
PULL DOWN MECHANISMS

Boa® Coil anchors and stud anchors such as TruBolt® anchors and chemical anchors also have the capability to clamp the fixture to the concrete.

Torque controlled expansion anchors without an adequate pull-down capability, suffer from loss of preload to the spacer or sleeve, whenever there is a gap between the mating surfaces. This results in a reduction in the preload available for compression of the concrete. Such anchors may perform under cyclic loads as if there were an inadequate preload, even though the specified assembly torque may have been carefully applied. In some instances it is possible for the fixture to be loose against the concrete surface from the time of initial assembly of the fixing.

Initial preload (P_{Li}) which is developed immediately after the application of assembly torque, is calculated for **Ramset** anchors as:

$$P_{Li} = \alpha * P_r$$

where:

α = proportion of proof load as initial preload
65% for mechanical anchors

$$P_r = \text{bolt or anchor proof load (kN)}$$

$$= A_s * f_y$$

Assembly torques required (T_r) to develop initial preloads are given by the following formula:

$$T_r = \mu_T * d_b * P_{Li}$$

where:

Note: η = ratio of allowable slip or cyclic load to expected long term limiting preload

μ_T = torque co-efficient of sliding friction
* 0.32 for cold-formed anchors and stainless steel anchors
* 0.37 for machined anchors

Long Term Preload

DEGRADATION

In considering the long term performance in concrete of expansion anchors under cyclic loading, account must be taken of concrete creep which causes a degradation of preload over time. Immediately after the application of assembly torque and the establishment of initial preload, there is a rapid initial reduction in preload, followed by a continued gradual reduction over time, towards a long term limiting value of "P_L", at "λ" % of initial preload. As a guide, "λ" may be taken as typically 70% for SpaTec Xtrem anchors, and as 40% for DynaBolt and TruBolt anchors.

In a particular application, the proportion of preload permanently retained will depend upon concrete strength, concrete quality including curing, level and direction of concrete stress, applied load level, timing of applied loads, and the value of the total spring rate for the anchor/fixture/base material system.

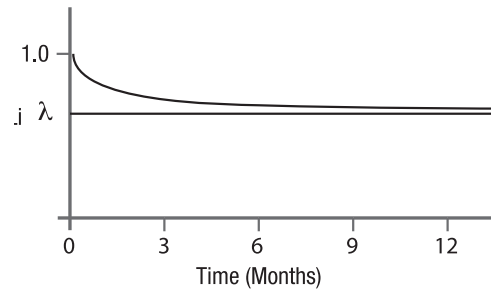

PRELOAD DEGRADATION

Slip/Cyclic Loading

ANCHORING TECHNOLOGY

Anchoring Technology

SLIP AND CYCLIC LOADING

Provided the applied load is less than the remaining preload, slip virtually does not occur, and the fixing experiences the applied load as a reduction in elastic compression of the concrete. When the applied load exceeds the preload, the clamped material can separate from the concrete and slippage of the joint can commence. If the design requirement is for negligible slip (say 0.1mm), the assembly torque should be both carefully specified and applied. It is recommended that anchor capacity be limited to a percentage of the expected preload after allowing for long term degradation.

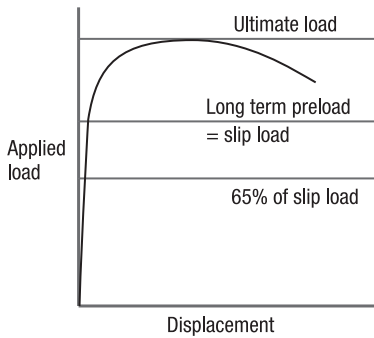

SLIP LOAD AND PRELOAD

The ability of an anchor to sustain cyclic loads depends (as for slip loads) primarily upon the relationship between the applied load and the effective preload in the anchor. Where the applied load is less than both the preload and the static working load, the fastening has the ability to withstand an infinite number of repetitions of the applied load. The cyclic loading is experienced as changes in pressure at the interface of the fixture and the concrete, and the stress range in the anchor should never approach the endurance limit. To ensure long life of the fastening under cyclic loading, the designer should ensure (as for slip loads), that the applied load is less than "η" % of the expected long term preload after allowing for degradation.

The Boa[®] Coil anchor performs more like a slight undercut anchor where the first slip measured at 0.1mm is close to the ultimate load of the anchor in concrete. The Boa[®] Coil anchors ability to sustain cyclic loads depends primarily upon the interaction of the Boa[®] Coil and the concrete sides of the hole.

It is this unique interaction that enables the Boa[®] Coil anchor to achieve high first slip loads. To ensure long life of the fastener under cyclic loading the designer should ensure (as for slip loads), that the applied load does not exceed 65% of the first slip load, called the reduced characteristic ultimate slip load. When the applied load is less than the reduced characteristic ultimate slip load the Boa[®] Coil anchor has the ability to withstand an infinite number of repetitions of the applied load.

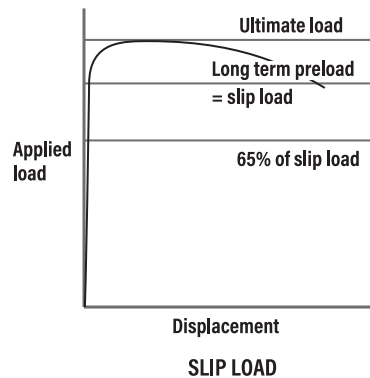

SLIP LOAD

Note: η = ratio of allowable slip or cyclic load to expected long term limiting preload

LONG TERM, SLIP & CYCLIC LOADING OF MECHANICAL & CHEMICAL ANCHORS

This section expands on the information stated under Sections 5.11 "Long Term Preload Degradation" & 5.12 "Slip Load and Cyclic Loading".

Mechanical and chemical anchorages, once installed, may be used to clamp down the fixture and so are loaded axially. The recommended initial setting or tightening torque is specified in each anchoring section of this book which creates the axial clamp down. The anchorage must resist this setting load and any additional applied load through the fixture itself.

The known behaviour of all loaded post-installed anchor systems is such that complex creep mechanisms are at work in the concrete and both system types (mechanical & chemical) display a limited relaxation of the installed tightening torque. This translates to a reduction (to a limit) of the installed clamping force and the resisting anchorage force. This is the "long term preload degradation". All **Ramset** systems are rated for the long term case and only this information is published.

In some load cases, particularly with combined & repetitious applied axial and shear loads, it is important that the applied axial load does not overcome the installed axial preload. This does not cause a structural failure as such but may allow some shear slippage of the fixture, depending on the surface & friction conditions. Precast panel prop anchors and roof structure anchors in cyclonic conditions are possible examples where this may be a concern.

For the deemed heavier duty **Ramset** anchor systems an applied load up to Working Load Limit, WLL ($N_{uc}/3$) will never exceed the axial preload

if installed as specified. Other systems (notably so-called "light sleeve anchors") have a lower limit on tensile load if exceeding preload is of concern. The table below shows the allowable slip or cyclic axial load (N_y) as a function of WLL (refer SRB) for various systems where infinite cycles of applied tensile load and retention of positive preload are considered:

System	N_y (allowable slip / cyclic axial load)
SpaTec [™] Xtrem [™]	WLL
TruBolt [™]	0.35 x WLL
Boa [™] Coil	WLL
ChemSet [™] Reo 502 [™] Plus	WLL
EPCON [™] C6 Plus	WLL
Maxima [™] Spin Capsule	WLL
AnkaScrew [™]	WLL
EPCON [™] C8 Xtrem [™]	WLL

Note: AS1170 relies on a 1.5 factor between Strength Limit State Design & WLL values.

Corrosion / Fire

ANCHORING TECHNOLOGY

CORROSION

During their service life, fasteners may be subjected to a range of corrosive agents and environments. Atmospheric environments may include the benign, such as indoors in dry conditions. The less benign outdoor areas are exposed to rain and/or humidity. The chloride bearing atmospheres under the influence of sea winds are more corrosive. The polluted atmosphere in some industrial areas, and the marine environment over the sea, at the shore, or within the splash zone, may be highly aggressive. Fastenings may be required to be placed under fresh water, salt water, or in contact with a whole range of potentially corrosive liquids. **Ramset** anchors are supplied with a range of corrosion resistances suitable for various applications.

There is a large number of specialist texts on the subject of corrosion, to which the reader is referred.

The stainless steel specification for **Ramset** anchors has a high molybdenum content, which gives superior resistance against chlorides and common industrial pollutants.

Stainless steel anchors should be insulated from the zinc coating, when securing galvanised steelwork, because of the possibility of galvanic corrosion.

Care must be taken to ensure selected fasteners meet the appropriate standards and are also correctly described.

The term "galvanised" in this document refers to hot dip galvanising according to the Australian Standards listed in the table below.

Note that other publications may use the term "galvanised" when referring to zinc electroplated anchors, which provides inferior corrosion protection. To ensure adequate corrosion protection, verify that the plating thickness complies with the thickness value required by the relevant Australian Standard. **AS/NZS 1214 - 2016** requires a minimum of 42 micron thickness for "hot dip galvanised" threaded items.

ENVIRONMENT	CORROSION PROTECTION	SPECIFICATION
Indoors, under cover Low humidity Exposure to moisture likely	Plating	Zinc plated Minimum thickness 5 micron
Exposed to weather Industrial pollution Marine environments	Galvanising	Hot dipped to AS4680-2006 AS/NZS 1214-2016 Minimum thickness 42 micron
Chemical plants Aggressive environments At the sea	Stainless steel	ISO3506-1979 Grade A4, Prop Class 70 (AISI 316)

FIRE

When exposed to heat so that it reaches a temperature of about 550°C, steel retains about half of its original strength. Designers have traditionally adopted this limiting temperature for the retention of structural integrity. Expansion and cast-in anchors manufactured in steel, are subject to the same limit, except that conditions are generally more favourable to the retention of structural strength for these anchors, than other components of an unprotected structure. For example, in circumstances where heat can be expected to vent through the roof sheeting, there is little risk of the fixings at the supports of steel beams, reaching the same temperature as the most critical part of the main steel structural elements. Generally, fixings reach significantly lower temperatures than the main structural elements.

Part of an anchor is always embedded in and insulated by the concrete, which increases the time for the heat to flow to the anchoring element of the anchor, and because of the heat sink of the concrete mass which takes heat from the anchor, there is an increase in the time for its temperature to rise.

Fire induced deformations of wall panels, and the behaviour of the structural frame under fire, should be carefully considered in the design. Spread of the fire to adjoining properties will be prevented, as long as the panels remain fixed to the structural frame. The connection between a heavy structural steel frame and the wall panels should be via deformable ties.

The limiting operational temperature for chemical anchors is 80°C. When used for anchoring reinforcing steel, chemical systems are provided with concrete cover, and may be designed to provide the desired fire rating, by limiting the temperature rise at the anchor points. Where protection is required for the steel structure, special fireproofing material is specified. The same protection should be extended to any exposed fixings to the concrete structure.

Introduction

SEISMIC ANCHORS

[Back to index](#)

Seismic Anchors

Introduction

This section of the Specifiers Resource Book provides you with solutions for post-installed anchors where there is a Seismic/Earthquake performance requirement. There are three international standards which are used to derive Seismic performance data for Mechanical and Chemical Anchors installed in concrete.

One standard is from the United States (ACI - American Concrete Institute) The second standard is from Europe (Eurocode 2 Part 4 and EOTA - European Organisation for Technical Assessment). The European Standard for metal anchors under seismic action was introduced in April 2013 and provides Category 1 performance (i.e. smaller earthquakes tested to 0.5mm

crack width & equivalent to current ACI 355.2/ACI 355.4 test methods) and Category 2 performance (i.e. larger earthquakes tested to 0.8mm crack width). The third standard is from Australia (Standards Australia AS5216) which references identical testing methodology to the European Standard.

The following flow chart provides you with guidance on how anchors are Seismically Certified;

Seismic Standards for Anchors

MECHANICAL & CHEMICAL

[Back to index](#)

Seismic Anchors

Flow Chart on Seismic Standards for Anchors

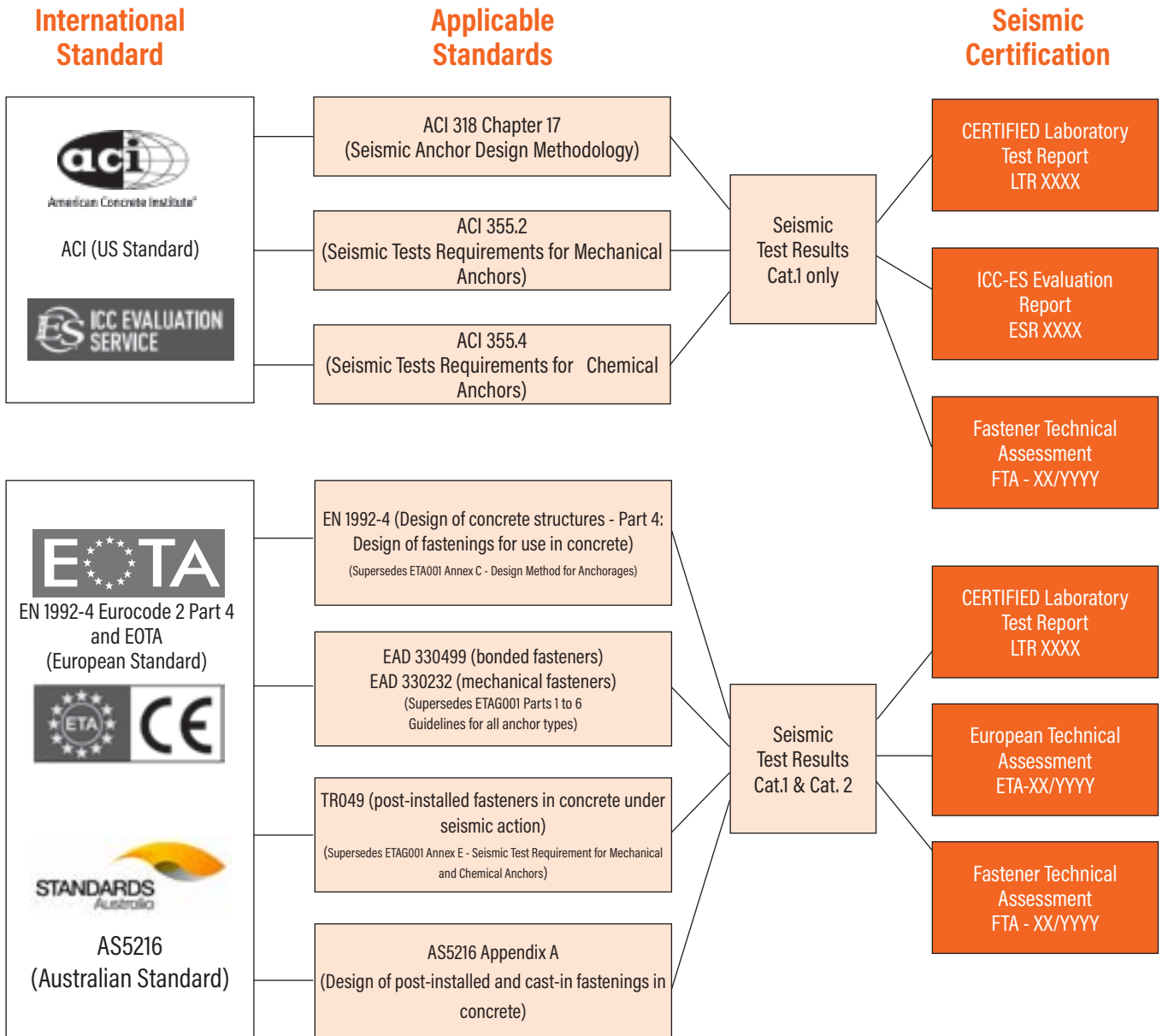

In summary, Mechanical & Chemical anchors can be seismically certified provided they are tested to the requirements of either standard. Proof of the certification can either be by a recognized report (i.e. ETA or ICC ESR) or a Certified Laboratory Test Report (i.e an independent test report based on an accredited laboratory's test results).

Seismic Anchors Overview

[Back to index](#)

MECHANICAL & CHEMICAL

Seismic Anchors

Seismic Requirement options for Mechanical & Chemical Anchors

Anchor Description	Application	Seismic Qualification	Image
EPCON™ C8 Xtrem™ used to install post-installed rebar	Rebar connections for wall, slab, columns and beams Starter Bars	✓ CSTB-3/12-727 Test as per ACI 355.4 ø10, ø12, ø16, ø20, ø24 ø25, ø28, ø32	
EPCON™ C8 Xtrem™ used to install metric anchor studs	Anchor studs for structural steel and metal work connections to concrete	✓ ETA-10/0309 Seismic C1 & C2 Test to EOTA TR049 (Supersedes ETAG001 Annex E) C1 - Std Stud M10 - M16 C2 - Std Stud M16 - M24	
EPCON™ C6 Plus used to install metric anchor studs and rebar	Anchor studs for structural steel and metal work connections to concrete	✓ ETA 18/0675 Seismic C1 Test to EOTA TR049 (Supersedes ETAG001 Annex E) C1 - Std Stud M10 - M30 C1 - Rebar ø10 - ø32	
Chemset™ Reo 502™ Plus used to install metric anchor studs and rebar	Anchor studs for structural steel and metal work connections to concrete	✓ ETA 18/0675 Seismic C1 Test to EOTA TR049 (Supersedes ETAG001 Annex E) C1 - Std Stud M10 - M30 C1 - Rebar ø10 - ø32	
ChemSet™ 801 Xtrem™ used to install metric & Xtrem™ anchor studs & post installed rebar	Anchor studs for structural steel and metal work connections to concrete & Rebar connections	✓ ETA 18/0045 Seismic C1 & C2 Test to EOTA TR049 (Supersedes ETAG001 Annex E) C1 - Std Stud M10 - M30 C1 - Rebar ø10 - ø20 C2 - Xtrem Stud M12 - M20	
SpaTec™ Xtrem™	Structural Steel, columns, beams.	✓ ETA-10/0276 Seismic C1 & C2 Test to EOTA TR049 (Supersedes ETAG001 Annex E) M10, M12, M16	
TruBolt™ Xtrem™	Structural Steel, columns, beams.	✓ ETA-15/0893 Seismic C1 & C2 Test to EOTA TR049 (Supersedes ETAG001 Annex E) M10, M12, M16, M20	
AnkaScrew™ Xtrem™	Steel Framing, Scaffolding Mech, Electrical, HVAC Overhead Suspension	✓ ETA 20/0731 Test to EOTA TR049 (Supersedes ETAG001 Annex E) C1 - 6mm - 12mm C2 - 8mm - 12mm	
Suspension Anchors	Steel Deck/ComFlor Mech, Electrical, HVAC Overhead Suspension	✓ University of Auckland* Seismic Test to ACI 355.2 & ACI93 AnkaScrew Xtrem Rod Holder M8-M10 AnkaScrew Xtrem Hex Head 6mm - 10mm TruBolt Xtrem Hex Head M10 - M12	

*University of Auckland Test Program conducted March 2021.

EPCON™ C8 Xtrem™

SEISMIC ANCHOR STUDS - CHEMICAL INJECTION

[Back to index](#)

GENERAL INFORMATION

Performance Related	Material Specification	Installation Related

Product

EPCON™ C8 Xtrem™ is a High Performance Pure Epoxy Anchoring adhesive for use in Cracked and Non-Cracked concrete. For structures subject to external exposure, permanently damp or aggressive conditions.



Compliance

European Technical Assessment (option 1) - ETA - 10/0309

Design according to:

- AS5216 (formerly TS101)
- AS1170.4 - Earthquake Actions
- EN1992-4 (formerly ETAG001 Annex C, E & TR045)
- NZS3101 (A3) Section 17 - Seismic Category C1 and C2
- Use enclosed data for simplified calculation method

Use Ramset™ iExpert Anchor Software for optimised calculation or where a greater range of anchor layout detail is needed.



Benefits, Advantages and Features

- 50 year working life
- Greater productivity:**
 - Anchors in dry, damp, wet or flooded holes
 - No weather delays
 - Fast, easy dispensing with high flow mixer
- Greater security:**
 - Highest performance in cracked concrete
- Versatile**
 - Anchors all stud & bar diameters in all directions
 - Oversized holes*
 - Anchors in carbide drilled and diamond cored holes*
 - For tropical and Cold weather conditions

Principal Applications

- Anchoring into cracked & non cracked concrete
- Road barrier hold down bolts
- Bridge refurbishment
- Road & Rail tunnel construction
- Reinforcing bar from 10 to 32mm
- Starter Bars
- Threaded studs from M8 to M30
- Threaded Stud material: Zn, A4 316, HCR steels
- Threaded Stud material: 5.8, 8.8, 10.9 grade

Greater safety:

- Low odour

Fire Rated : Refer Fire rated anchoring section

Recommended Installation Temperatures

	Minimum	Maximum
Substrate	5°C	40°C
Adhesive	5°C	40°C

Load should not be applied to anchor until the chemical has sufficiently cured as specified.

Installation

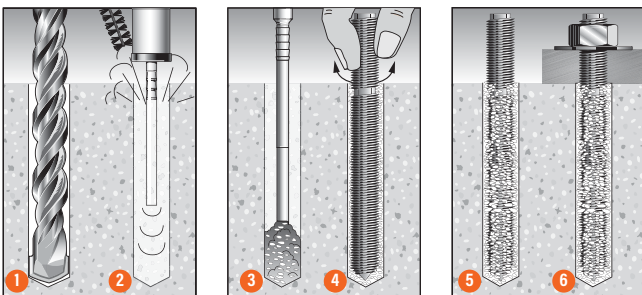

- Drill recommended diameter and depth hole.
- Important:** Use Ramset™ Dustless Drilling System to ensure holes are clean. Alternatively, clean dust and debris from hole with stiff wire or nylon brush and blower in the following sequence: blow x 2, brush x 2, blow x 2.
- Dispense adhesive to waste until colour is uniform light grey (2-3 trigger pulls). Insert mixing nozzle to bottom of hole. Fill hole to 3/4 the hole depth slowly, ensuring no air pockets form.
- Insert Ramset™ ChemSet™ Anchor Stud/rebar to bottom of hole while turning.
- Allow EPCON™ C8 Xtrem™ to cure as per setting times.
- Attach fixture.

Service Temperature Limits

-40°C to 80°C

Setting Times EPCON™ C8 Xtrem™

Temperature of base material	Gel Time	Curing time in dry concrete	Curing time in wet concrete
5°C - 9°C	20 min	30 h	60 h
10°C - 19°C	14 min	23 h	46 h
20°C - 24°C	11 min	16 h	32 h
25°C - 29°C	8 min	12 h	24 h
30°C - 39°C	5 min	8 h	16 h
40°C	5 min	6 h	12 h

Note

*Performance of cored & oversized holes was not included in the ETAG test program and therefore is based on testing conducted at Ramset™ Product Engineering Laboratory.

EPCON™ C8 Xtrem™

SEISMIC ANCHOR STUDS - CHEMICAL INJECTION

Installation and performance details: EPCON™ C8 Xtrem™ and ChemSet™ Anchor Studs

Anchor size, d _b (mm)	Drilled hole diameter, d _h (mm)	Fixture hole diameter, d _f (mm)	Anchor effective depth, h (mm)	Tightening torque, T _r (Nm)	Optimum dimensions*			C1 & C2 Seismic Cracked Concrete reduced characteristic tensile capacity, N ^o _{Rd,s,seis} (kN) ** ***					
					Anchor spacing, a _c (mm)	Edge distance, e _c (mm)	Concrete substrate thickness, b _m (mm)	Concrete Compressive Strength, f' _c					
								20 MPa		30 MPa		40 MPa	
								C1	C2	C1	C2	C1	C2
M10	12	12	90	20	270	135	120	8.3	-	8.7	-	8.9	-
M12	14	14	110	30	330	165	140	11.2	-	11.7	-	12.2	-
M16	18	18	125	60	375	187.5	161	20.2	13.6	21.4	14.5	22.4	15.1
M20	25	22	170	120	510	255	220	-	17.1	-	18.4	-	19.6
M24	28	26	210	200	630	315	266	-	23.2	-	25.3	-	26.9

* If anchor spacing and/or edge distance is less than optimum, please refer to simplified strength limit state design process to verify capacity.

** Tension values based on service temperature limits -40°C to +40°C only. If service temperature limits are beyond this range please contact Ramset Engineer.

***Note: Seismic Cracked concrete combined pull-out and concrete cone resistance, tension = N^o_{Rd,s,seis} = α_{N,seis} * N^o_{Rk,s,seis} / γ_{Msp} where γ_{Msp} = 1.8

Flooded Holes: Multiply N^o_{Rd,s,seis} *0.68

For single anchor values: Multiply N^o_{Rd,s,seis} *1.17

Anchor size, d _b (mm)	Reduced Characteristic Capacity											
	Grade 5.8 Steel Studs			Grade 8.8 Steel Studs			ANSI 316 Stainless Steel Studs			HCR 1.4529 Stainless Steel Studs		
	Shear, V _{Rd,s,seis} (kN)		Tension, N _{Rd,s,seis} (kN)****	Shear, V _{Rd,s,seis} (kN)		Tension, N _{Rd,s,seis} (kN)****	Shear, V _{Rd,s,seis} (kN)		Tension, N _{Rd,s,seis} (kN)****	Shear, V _{Rd,s,seis} (kN)		Tension, N _{Rd,s,seis} (kN)****
	C1	C2	C1 & C2	C1	C2	C1 & C2	C1	C2	C1 & C2	C1	C2	C1 & C2
M10	3.6	-	19.3	5.5	-	30.7	3.8	-	21.9	2.6	-	14.6
M12	5.0	-	28.0	8.1	-	44.7	5.7	-	31.6	3.7	-	21.2
M16	9.3	7.0	52.7	15.0	11.4	84.0	10.5	7.9	58.8	7.0	5.3	39.2
M20	-	12.2	82.0	-	19.7	130.7	-	13.8	92.0	-	9.2	61.2
M24	-	19.8	118.0	-	31.7	188.0	-	22.3	132.1	-	14.8	88.1

****Note: Seismic Cracked concrete steel resistance, tension = N_{Rd,s,seis} = α_{N,seis} * N_{Rk,s,seis} / γ_{Ms} (kN) where γ_{Ms} = 1.5 (Grade 5.8 & 8.8 steel)

γ_{Ms} = 1.87 (A4 316 SS); γ_{Ms} = 2.6 (HCR stainless steel) and α_{N,seis} = 1

For optimised performance data, please use Ramset iExpert Anchoring Software.

Injection System

Description	Cartridge Size	Part No.
EPCON™ C8 Xtrem™	450 ml	C8-450

Drilled hole depth, h₁ (mm)
h₁ = h
h = Effective depth

ENGINEERING PROPERTIES

ChemSet™ Anchor Studs and Threaded Rod

Anchor Size, d _b	Grade 8.8 Threaded Rod				Stainless Steel High Corrosion Resistance HCR Grade 1.4529/1.4565 Threaded Rod				Section modulus Z (mm ³)
	Shank diameter, d _s (mm)	Stressed Area (mm ²)	Yield Strength f _y (MPa)	UTS f _u (MPa)	Shank diameter, d _s (mm)	Stressed Area (mm ²)	Yield Strength f _y (MPa)	UTS f _u (MPa)	
M10	8.6	58	640	800	8.2	52.8	450	650	62.3
M12	10.4	84.3	640	800	10	78.5	450	650	109.2
M16	14.1	157	640	800	14	153.9	450	650	277.5
M20	17.7	245	640	800	17.2	232.4	450	650	540.9
M24	21.2	353	640	800	20.7	336.5	450	650	935.5

Refer to "Engineering Properties" for ChemSet™ Anchor Studs Grade 5.8 and AISI 316 Stainless Steel in the SARB ANZ on page 141.

EPCON™ C8 Xtrem™

STRENGTH LIMIT STATE DESIGN

STEP 1 Select anchor to be evaluated

Table 1a - Indicative combined loading - interaction diagram

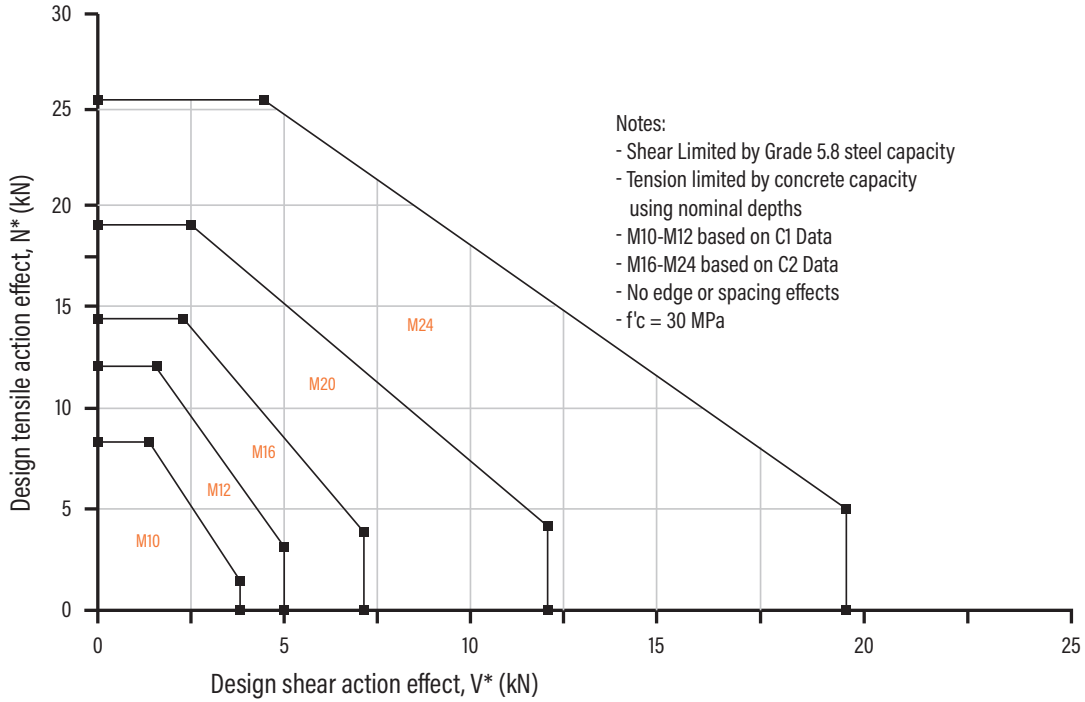

Table 1b - Absolute minimum edge distance and anchor spacing values, e_m and a_m (mm) for cracked concrete

Anchor size, d_b	M10	M12	M16	M20	M24
Min. Anchor spacing - a_m	50	60	80	100	120
Min. Edge Distance - e_m	50	60	80	100	120

Step 1c Calculate anchor effective depth, h (mm)

Refer to "Description and Part Numbers" table for ChemSet Anchor Studs in the SARB ANZ on page 141.

Effective depth, h (mm)

Preferred $h = h_n$ otherwise,

$h = L_e - t$

$t = \text{total thickness of material(s) being fastened.}$

Substrate thickness b_m (mm)		
Anchor Stud Size (mm)		
M10	M12	M16 - M24
$h + 30\text{mm} \geq 100\text{mm}$		$h + (2 \times d_n)$

Checkpoint 1 Anchor size determined, absolute minima compliance achieved, effective depth (h) calculated.

EPCON™ C8 Xtrem™

STRENGTH LIMIT STATE DESIGN

Seismic Anchors - EPCON™ C8 Xtrem™ - Anchor Studs

STEP 2 Verify seismic C1& C2 cracked concrete combined pull-out and concrete cone tensile resistance - per anchor

Table 2a - Seismic Cracked concrete combined Pull-out and concrete cone resistance, tension

$$N_{Rd,p,seis}^0 = \alpha_{N,seis} N_{Rk,p,seis}^0 / \gamma_{Msp} \text{ (kN)}, \gamma_{Msp} = 1.8, \alpha_{N,seis} = 0.85, f'_c = 30 \text{ MPa}$$

$$\text{where } N_{Rk,p,seis}^0 = \pi * d_b * h * \tau_{Rk,cr,seis}$$

Anchor size, d _b	C1 Seismic Data			C2 Seismic Data		
	M10	M12	M16	M16	M20	M24
Drill hole dia, d _h (mm)	12	14	18	18	25	28
Effective depth, h (mm)						
60	5.8					
70	6.8	7.5				
80	7.7	8.5	13.7	9.3		
90	8.7	9.6	15.4	10.4	9.7	
100	9.7	10.7	17.1	11.6	10.8	
110	10.6	11.7	18.8	12.7	11.9	
120	11.6	12.8	20.5	13.9	13.0	14.4
125	12.1	13.3	21.4	14.5	13.5	15.0
140	13.5	14.9	24.0	16.2	15.1	16.8
150	14.5	16.0	25.7	17.4	16.2	18.0
160	15.5	17.0	27.4	18.5	17.3	19.2
170	16.4	18.1	29.1	19.7	18.4	20.5
180	17.4	19.2	30.8	20.8	19.4	21.7
190	18.3	20.2	32.5	22.0	20.5	22.9
200	19.3	21.3	34.2	23.1	21.6	24.1
210		22.4	35.9	24.3	22.7	25.3
240		25.6	41.1	27.8	25.9	28.9
280			47.9	32.4	30.2	33.7
320			54.7	37.0	34.5	38.5
400					43.2	48.1
450						54.1
480						57.7

Bold values are at ChemSet™ Anchor Stud nominal depths

Flooded Holes: Multiply N_{Rd,p,seis}⁰ *0.68

For single anchor values: Multiply N_{Rd,p,seis}⁰ *1.17

For optimised performance data, please use Ramset iExpert Anchoring Software.

Table 2b-1 - Seismic Cracked concrete service temperature limits effect, tension, X_{ts}

Service temperature (°C)	X _{ts}
-40°C to +40°C	1.00
-40°C to +80°C	0.53

Table 2b-2 - Seismic Cracked concrete compressive strength effect, tension, X_{nc}

Anchor size, d _b	Concrete compressive strength effect, tension, X _{nc}				
	M10	M12	M16	M20	M24
f'c (MPa)					
20	0.95	0.95	0.94	0.93	0.92
25	0.97	0.97	0.97	0.96	0.95
30	1.00	1.00	1.00	1.00	1.00
40	1.03	1.04	1.05	1.07	1.06
50	1.05	1.07	1.08	1.09	1.10

EPCON™ C8 Xtrem™

STRENGTH LIMIT STATE DESIGN

Seismic Anchors - EPCON™ C8 Xtrem™ - Anchor Studs

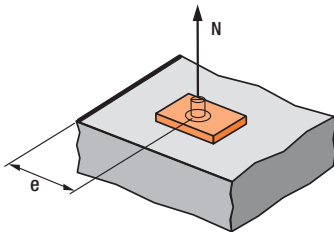

$$X_{ne} = 0.25 + 0.5*(e/h)$$

Where $e_m \leq e \leq e_c$

$$e_c = 1.5*h$$

Note: Tabled values are based on the nominal effective depth, h shown in the installation details. For other values of X_{ne} , please use equation shown above.

Table 2c - Concrete Edge distance effect, tension, X_{ne}

Anchor size, d_b	M10	M12	M16	M20	M24
Edge distance, e (mm)					
50	0.53				
60	0.58	0.52			
80	0.69	0.61	0.57		
90	0.75	0.66	0.61		
100	0.81	0.70	0.65	0.54	
120	0.92	0.80	0.73	0.60	0.54
135	1.00	0.86	0.79	0.65	0.57
165		1.00	0.91	0.74	0.64
187			1.00	0.80	0.70
255				1.00	0.86
315					1.00

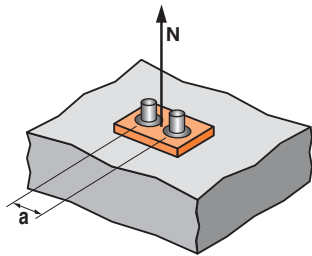

$$X_{na} = 0.5 + a/(6*h)$$

Where $a_m \leq a \leq a_c$

$$a_c = 3*h$$

Note: Tabled values are based on the nominal effective depth, h shown in the installation details. For other values X_{na} , please use equation shown above.

Table 2d - Seismic Cracked concrete anchor spacing effect, tension, X_{na}

Anchor size, d_b	M10	M12	M16	M20	M24
Anchor spacing, a (mm)					
50	0.59				
60	0.61	0.59			
80	0.65	0.62	0.61		
100	0.69	0.65	0.63	0.60	
120	0.72	0.68	0.66	0.62	0.60
140	0.76	0.71	0.69	0.64	0.61
160	0.80	0.74	0.71	0.66	0.63
200	0.87	0.80	0.77	0.70	0.66
270	1.00	0.91	0.86	0.76	0.71
330		1.00	0.94	0.82	0.76
375			1.00	0.87	0.80
510				1.00	0.90
630					1.00

Checkpoint 2

Design seismic cracked concrete combined pull-out and concrete cone resistance, $N_{Rd,p,seis}$

$$N_{Rd,p,seis} = N^0_{Rd,p,seis} * X_{ns} * X_{nc} * X_{ne} * X_{na}$$

STEP 3

Verify Seismic C1 & C2 tensile resistance - per anchor

Table 3a - Seismic Cracked Concrete steel resistance, tensile, $N_{Rd,s,seis} = \alpha_{seis} N_{Rk,s,seis} / \gamma_{Ms}$ (kN) where $\alpha_{seis} = 1.0$

$\gamma_{Ms} = 1.5$ for Grade 5.8 and Grade 8.8 Carbon Steel

$\gamma_{Ms} = 1.87$ for A4 316 Stainless Steel

$\gamma_{Ms} = 2.6$ for HCR 1.4529 Stainless Steel

Anchor size, d_b	M10	M12	M16	M20	M24
Grade 5.8 Carbon Steel	19.3	28.0	52.7	82.0	118.0
Grade 8.8 Carbon Steel	30.7	44.7	84.0	130.7	188.0
A4 316 Stainless Steel	21.9	31.6	58.8	92.0	132.1
HCR 1.4529 Stainless Steel	14.6	21.2	39.2	61.2	88.1

Checkpoint 3

Design Seismic C1 & C2 cracked concrete tensile resistance, $N_{Rd,seis}$

$$N_{Rd,seis} = \text{minimum of } N_{Rd,p,seis}, N_{Rd,s,seis}$$

Check $N^*/N_{Rd,seis} \leq 1$,

if not satisfied return to step 1

EPCON™ C8 Xtrem™

STRENGTH LIMIT STATE DESIGN

Seismic Anchors - EPCON™ C8 Xtrem™ - Anchor Studs

STEP 4

Verify Seismic C1& C2 cracked concrete edge shear resistance - per anchor

Table 4a - Seismic cracked concrete edge resistance, $V_{Rd,c,seis}^0 = \alpha_{seis} V_{Rk,c,seis}^0 / \gamma_{Mc}$ (kN)

$\gamma_{Mc} = 1.5, \alpha_{seis} = 0.85, f'_c = 30 \text{ MPa}$

Anchor size, d_b	M10	M12	M16	M20	M24
Effective depth, h (mm)	90	110	125	170	210
Edge distance, e_m					
50	1.8				
60		2.4			
80			3.8		
100				5.7	
120					7.8

Note: Data includes annular gap reduction factor of 0.5

For optimised performance data, please use Ramset iExpert Anchoring Software.

Table 4b - Seismic cracked concrete compressive strength effect, shear, X_{vc}

f'_c (MPa)	20	25	30	40	50
X_{vc}	0.82	0.9	1.0	1.16	1.27

Table 4c - Seismic cracked concrete load direction effect, concrete edge shear, X_{vd}

Angle, α°	0-55	60	70	80	90-180
X_{vd}	1	1.1	1.2	1.5	2

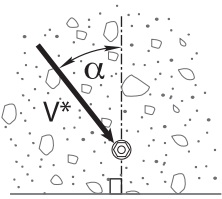

Load direction effect, conc. edge shear, X_{vd}

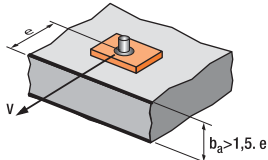

$$X_{ve} = e/e_m * \sqrt{e/e_m}$$

Table 4d - Seismic cracked concrete anchor spacing and edge distance effect, concrete edge shear, X_{ve}

For single anchor fastening X_{ve}

e/e_m	1.0	1.2	1.4	1.6	1.8	2.0	2.2	2.4	2.6	2.8	3.0	3.2
X_{ve}	1.00	1.31	1.66	2.02	2.41	2.83	3.26	3.72	4.19	4.69	5.20	5.72

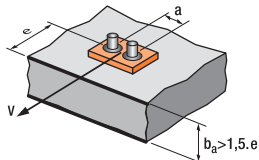

$$X_{ve} = \frac{3*e+a}{6*e_m} * \sqrt{e/e_m}$$

For 2 anchors fastening X_{ve}

e/e_m	1.0	1.2	1.4	1.6	1.8	2.0	2.2	2.4	2.6	2.8	3.0	3.2
a/e_m												
1.0	0.67	0.84	1.03	1.22	1.43	1.65	1.88	2.12	2.36	2.62	2.89	3.16
1.5	0.75	0.93	1.12	1.33	1.54	1.77	2.00	2.25	2.50	2.76	3.03	3.31
2.0	0.83	1.02	1.22	1.43	1.65	1.89	2.12	2.38	2.63	2.90	3.18	3.46
2.5	0.92	1.11	1.32	1.54	1.77	2.00	2.25	2.50	2.77	3.04	3.32	3.61
3.0	1.00	1.20	1.42	1.64	1.88	2.12	2.37	2.63	2.90	3.18	3.46	3.76
3.5		1.30	1.52	1.75	1.99	2.24	2.50	2.76	3.04	3.32	3.61	3.91
4.0			1.62	1.86	2.10	2.36	2.62	2.89	3.17	3.46	3.75	4.05
4.5				1.96	2.21	2.47	2.74	3.02	3.31	3.60	3.90	4.20
5.0					2.33	2.59	2.87	3.15	3.44	3.74	4.04	4.35
5.5						2.71	2.99	3.28	3.71	4.02	4.33	4.65
6.0						2.83	3.11	3.41	3.71	4.02	4.33	4.65

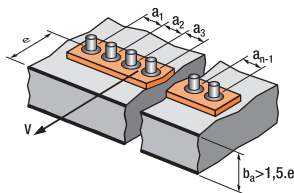

For 3 anchors fastening and more

$$X_{ve} = \frac{3*e + a_1 + a_2 + a_3 + \dots + a_{n-1}}{3*n*e_m} * \sqrt{e/e_m}$$

EPCON™ C8 Xtrem™

STRENGTH LIMIT STATE DESIGN

Table 4e - Seismic Cracked concrete Pryout failure, $V_{Rd,cp,seis}^0 = \alpha_{seis} V_{Rk,cp} / \gamma_{Mpr}$ (kN)

$\gamma_{Mpr} = 1.5, \alpha_{seis} = 0.75, f'_c = 30 \text{ MPa}$

Anchor size, d_b		M10	M12	M16	M20	M24
Effective depth, h (mm)		90	110	125	170	210
-40 °C to +40 °C	C1 Seismic Data	9.2	12.4	22.6	-	-
	C2 Seismic Data	-	-	15.3	19.4	26.8
-40 °C to +80 °C	C1 Seismic Data	5.3	7.0	12.0	-	-
	C2 Seismic Data	-	-	6.2	7.0	8.7

Note: Data includes annular gap reduction factor of 0.5
For single anchor values: Multiply $V_{Rd,cp,seis}^0$ *1.13

Table 4f - Anchor at a corner effect, concrete edge shear, X_{VS}

Note: For $e_1/e_2 > 1.25, X_{VS} = 1.0$

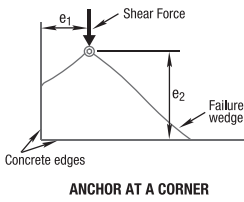

Edge distance, e_2 (mm)	50	60	75	125	200	300	400	600	900
Edge distance, e_1 (mm)									
50	0.86	0.77	0.67	0.52	0.44	0.39	0.37	0.35	0.33
60	0.97	0.86	0.75	0.57	0.47	0.41	0.38	0.36	0.34
75	1.00	1.00	0.86	0.64	0.51	0.44	0.41	0.37	0.35
125	1.00	1.00	1.00	0.86	0.65	0.53	0.48	0.42	0.38
200	1.00	1.00	1.00	1.00	0.86	0.67	0.58	0.49	0.42
300	1.00	1.00	1.00	1.00	1.00	0.86	0.72	0.58	0.49
400	1.00	1.00	1.00	1.00	1.00	1.00	0.86	0.67	0.55
500	1.00	1.00	1.00	1.00	1.00	1.00	1.00	0.77	0.61
600	1.00	1.00	1.00	1.00	1.00	1.00	1.00	0.86	0.67
900	1.00	1.00	1.00	1.00	1.00	1.00	1.00	1.00	0.86

Checkpoint 4a

Design seismic cracked concrete edge shear resistance, $V_{Rd,c,seis}$
 $= V_{Rd,c,seis}^0 * X_{vc} * X_{vd} * X_{ve} * X_{vs}$

Checkpoint 4b

Design seismic cracked concrete Pryout failure,
 $V_{Rd,cp,seis} = V_{Rd,cp,seis}^0 * X_{nc} * X_{ne} * X_{na}$

STEP 5

Verify Seismic C1 & C2 cracked concrete shear resistance - per anchor

Table 5a - Seismic Cracked Concrete steel shear resistance, $V_{Rd,s,seis} = \alpha_{seis} V_{Rk,s,seis} / \gamma_{Ms}$ (kN)

where $\alpha_{seis} = 0.85$

$\gamma_{Ms} = 1.25$ for Grade 5.8 and Grade 8.8 Carbon Steel

$\gamma_{Ms} = 1.56$ for A4 316 Stainless Steel

$\gamma_{Ms} = 2.17$ for HCR Stainless Steel

Anchor size, d_b	C1 Seismic Data			C2 Seismic Data		
	M10	M12	M16	M16	M20	M24
Grade 5.8 Carbon Steel	3.6	5.0	9.3	7.0	12.2	19.8
Grade 8.8 Carbon Steel	5.5	8.1	15.0	11.4	19.7	31.7
A4 316 Stainless Steel	3.8	5.7	10.5	7.9	13.8	22.3
HCR Stainless Steel	2.6	3.7	7.0	5.3	9.2	14.8

Note: Data includes annular gap reduction factor of 0.5

For single anchor values: Multiply $V_{Rd,s,seis}^0$ *1.17

Checkpoint 5

Design seismic C1 & C2 cracked concrete shear resistance, $V_{Rd,seis}$
 $V_{Rd,seis} = \text{minimum of } V_{Rd,c,seis}, V_{Rd,cp,seis}, V_{Rd,s,seis}$
 Check $V^*/V_{Rd,seis} \leq 1$,
 if not satisfied return to step 1

EPCON™ C8 Xtrem™

STRENGTH LIMIT STATE DESIGN

Seismic Anchors - EPCON™ C8 Xtrem™ - Anchor Studs

STEP 6 Combined Loading

Checkpoint 6

Check

$$N^*/N_{Rd,seis} + V^*/V_{Rd,seis} \leq 1.0,$$

if not satisfied return to step 1

Specify - Threaded Stud Anchors
 Ramset™ EPCON™ C8 Xtrem™ with (Anchor Size) grade 5.8 ChemSet™ Anchor Stud (Anchor Stud Part Number) Drilled Hole Depth to be (h) mm.

Example
 Ramset™ EPCON™ C8 Xtrem™ Injection with M16 grade 5.8 ChemSet™ Anchor Stud (CS16190GH). Drilled hole depth to be 125mm. To be installed according to Ramset™ Installation Instructions.

Use Ramset™ iExpert Anchor Software for optimised calculation or where a greater range of anchor layout detail is needed

EPCON™ C8 Xtrem™

SEISMIC REINFORCING BAR - CHEMICAL INJECTION

[Back to index](#)

GENERAL INFORMATION

Performance Related	Installation Related

Product

EPCON™ C8 Xtrem™ is a High Performance Pure Epoxy Anchoring adhesive for use in Cracked and Non-Cracked concrete. For structures subject to external exposure, permanently damp or chemically aggressive conditions.



Compliance

European Technical Assessment - ETA - 07/0189

Design according to:

- AS5216 (formerly TS101)
 - AS1170.4 - Earthquake Actions
 - EN1992-1-1
 - CSTB Seismic Applications Report 3/12-727
- Use enclosed data for simplified calculation method

Use Ramset™ iExpert Anchor Software for optimised calculation or where a greater range of anchor layout detail is needed.

Benefits, Advantages and Features

- 100 year working life
- Greater productivity:**
 - Anchors in dry, damp, wet or flooded holes
 - No weather delays
 - Fast, easy dispensing with high flow mixer

Greater security:

- Highest performance in cracked concrete

Versatile

- Anchors all stud & bar diameters in all directions
- Oversized holes*
- Anchors in carbide drilled and diamond cored holes
- For tropical and Cold weather conditions

Greater safety:

- Low odour

Fire Rated : Refer Fire rated anchoring section

Installation

Drill recommended diameter and depth hole.

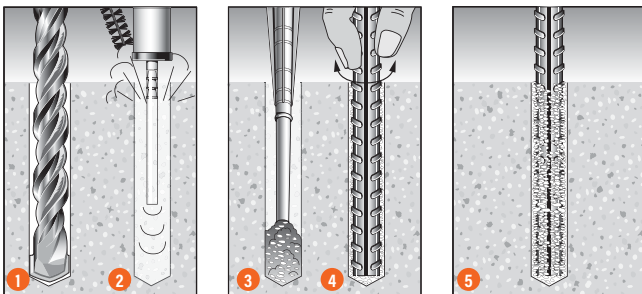

Important:

- Use Ramset™ Dustless Drilling System to ensure holes are clean.
- Alternatively, clean dust and debris from hole with stiff wire or nylon brush and blower in the following sequence: blow x 2, brush x 2, blow x 2.
- Dispense adhesive to waste until colour is uniform light grey (2-3 trigger pulls). Insert mixing nozzle to bottom of hole. Fill hole to 3/4 the hole depth slowly, ensuring no air pockets form.
- Insert Ramset™ ChemSet™ rebar to bottom of hole while turning.
- Allow EPCON™ C8 Xtrem™ to cure as per setting times.



Principal Applications

- Anchoring into cracked & non cracked concrete
- Road barrier hold down bolts
- Bridge refurbishment
- Road & Rail tunnel construction
- Reinforcing bar from 10 to 32mm
- Starter Bars
- Threaded studs from M8 to M30
- Threaded Stud material: Zn, A4 316, HCR steels
- Threaded Stud material: 5.8, 8.8, 10.9 Grade

Recommended Installation Temperatures

	Minimum	Maximum
Substrate	5°C	40°C
Adhesive	5°C	40°C

Load should not be applied to anchor until the chemical has sufficiently cured as specified.

Service Temperature Limits

-40°C to 80°C

Setting Times EPCON™ C8 Xtrem™

Temperature of base material	Gel Time	Curing time in dry concrete	Curing time in wet concrete
5°C - 9°C	20 min	30 h	60 h
10°C - 19°C	14 min	23 h	46 h
20°C - 24°C	11 min	16 h	32 h
25°C - 29°C	8 min	12 h	24 h
30°C - 39°C	5 min	8 h	16 h
40°C	5 min	6 h	12 h

Note

*Performance of oversized holes was not included in the ETAG test program and therefore is based on testing conducted at Ramset™ Concrete Structures Laboratory.

Seismic Anchors - EPCON™ C8 Xtrem™ - Reinforcing Bar

EPCON™ C8 Xtrem™

STRENGTH LIMIT STATE DESIGN

Installation and seismic performance details:

Anchor size, d_b (mm)	Drilled hole diameter, d_h (mm)	Nominal Yield (kN)	Min Anchor spacing (mm)	min. cover (mm)	Development length require to reach Nominal Yield strength (mm)		
					Concrete Compressive Strength, f'_c		
					20 MPa	25 MPa	30 MPa
10	12	39.3	40	55	543	463	417
12	15	56.5	48	60	652	556	500
16	20	100.5	64	70	870	741	667
20	25	157.0	80	80	1087	926	833
24	30	226.0	100	93	1359	1157	1042
25	30	245.5	100	93	1359	1157	1042
28	35	308.0	112	100	-	1296	1167
32	40	402.0	128	110	-	1481	1333

*Development length require are on service temperature limits -40°C to +40°C only. If service temperature limits is beyond this range please contact Ramset Engineer.

FOR DETAILED STRENGTH LIMIT STATE SEISMIC DESIGN DATA ON EPCON™ C8 Xtrem™, REFER TO SEISMIC REPORT No. CSTB 3/12-727

DESCRIPTION AND PART NUMBERS

Description	Cartridge Size	Part No.
EPCON™ C8 Xtrem™	450 ml	C8-450

Drilled hole depth, h_1 (mm)
 $h_1 = h$
 h = Effective depth

ENGINEERING PROPERTIES

Typical Engineering Properties of Grade 500 Reinforcing Bar

Rebar Size	10	12	16	20	24	25	28	32
Drilled Hole Dia, d_h (mm)	12	15	20	25	30	30	35	40
Stress Area, A_s (mm ²)	78.5	113	201	314	452	491	616	804
Yield Stress, f_{sy} (MPa)	500	500	500	500	500	500	500	500
Tensile Steel Yield Capacity, N_{sy} (kN)	39.3	56.5	100.5	157.0	226.0	245.5	308.0	402.0

For further information refer to reinforcing bar manufacturer's published information and current revision of AS/NZS 4671

EPCON™ C6 PLUS

SEISMIC ANCHOR STUDS - CHEMICAL INJECTION

Back to index

AVAILABLE IN NEW ZEALAND ONLY

(Australia refer to ChemSet™ Reo502™ PLUS range)

GENERAL INFORMATION

Performance Related	Material Specification	Installation Related

Product

EPCON™ C6 PLUS is a heavy duty pure Epoxy for anchoring threaded studs and reinforcing bar into cracked and uncracked concrete.



Compliance

European Technical Assessment (option 1) - ETA-18/0675

Design according to:

- AS1170.4 - Earthquake Actions
- EN1992-4 (formerly ETAG001 Annex C, E & TR045)
- NZS3101 (A3) Section 17 - Seismic Design C1
- Use enclosed data for simplified calculation method

Use Ramset™ iExpert Anchor Software for optimised calculation or where a greater range of anchor layout detail is needed.



Benefits, Advantages and Features

- 100 year working life
- Greater productivity:**
 - Anchors in dry, damp, wet or flooded holes
 - Easy dispensing even in cold weather
- Greater security:**
 - Strong bond
 - Rated for sustained loading
- Versatile:**
 - Anchors in carbide drilled and diamond drilled holes*
 - Cold and temperate climates
- Greater safety:**
 - Low odour
 - VOC Compliant
 - Suitable for contact with drinking water

Principal Applications

- Threaded Studs
- Starter Bars
- Threaded Inserts
- Over-head installation
- Steel Columns
- Hand Rails
- Road Stitching

Recommended Installation Temperatures

	Minimum	Maximum
Substrate	5°C	40°C
Adhesive	10°C	40°C

Installation

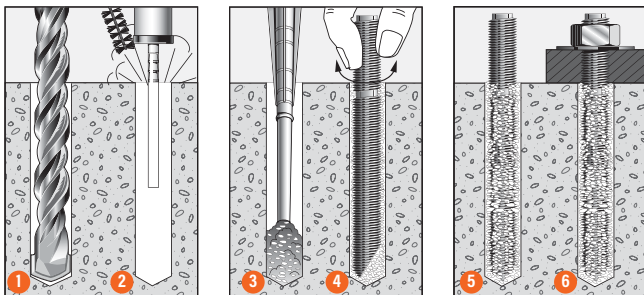

1. Drill recommended diameter and depth hole.
2. **Important:** Use Ramset™ Dustless Drilling System to ensure holes are clean. Alternatively clean dust and debris from hole with stiff wire or nylon brush and blower in the following sequence: blow x 2, brush x 2, blow x 2, brush x 2, blow x 2.
3. Dispense adhesive to waste until colour is uniform light grey (2-3 trigger pulls). Insert mixing nozzle to bottom of hole. Fill hole to 3/4 the hole depth slowly, ensuring no air pockets form.
4. Insert Ramset™ ChemSet™ Anchor Stud/rebar to bottom of hole while turning.
5. Allow EPCON™ C6 PLUS to cure as per setting times.
6. Attach fixture.

Service Temperature Limits

-40°C to 70°C

Setting Times

Temperature of base material	Cartridge Temperature	Gel Time	Curing time in dry and wet concrete
5°C	Minimum 10°C	300 min	24 h
10°C	10°C	150 min	18 h
15°C	15°C	40 min	12 h
20°C	20°C	25 min	8 h
25°C	25°C	18 min	6 h
30°C	30°C	12 min	4 h
40°C	40°C	6 min	2 h

Note: Cartridge temperature minimum +10°C

Note

*Performance of cored & oversized holes was not included in the ETAG test program and therefore is based on testing conducted at Ramset™ Product Engineering Laboratory.

EPCON™ C6 PLUS

SEISMIC ANCHOR STUDS - CHEMICAL INJECTION

AVAILABLE IN NEW ZEALAND ONLY

Installation and performance details: EPCON™ C6 Plus and ChemSet™ Anchor Studs

Anchor size, d _b (mm)	Drilled hole diameter, d _h (mm)	Fixture hole diameter, d _f (mm)	Anchor effective depth, h (mm)	Tightening torque, T _r (Nm)	Optimum dimensions*		Concrete substrate thickness, b _m (mm)	Seismic C1 Cracked Concrete reduced characteristic tensile capacity, N ^o _{Rd,p,seis} (kN) **		
					Anchor* spacing, a _c (mm)	Edge* distance, e _c (mm)		Concrete Compressive Strength, f _c		
								20 MPa	30 MPa	40 MPa
								C1	C1	C1
M10	12	12	90	20	270	135	120	13.6	14.2	14.6
M12	14	14	110	40	330	165	140	17.9	18.6	19.1
M16	18	18	125	80	375	188	161	23.5	24.4	25.1
M20	22	22	170	120	510	255	214	40.3	41.9	43.1
M24	26	26	210	160	630	315	262	51.8	53.9	55.4
M30	35	33	280	200	840	420	350	69.6	72.4	74.5

* For anchor spacings or edge distances less than the minimum, please refer to the simplified strength limit state design process to verify capacity.

** Tension values are based on service temperature limits -40 °C to +70 °C only. If service temperature limits is beyond this range please contact Ramset Engineer.

***Note: Seismic Cracked concrete combined pull-out and concrete cone resistance, tension = N^o_{Rd,p,seis} = α_{Nseis} N^o_{Rk,p,seis} / γ_{Msp} where γ_{Msp} = 1.5

Anchor size, d _b (mm)	Reduced Characteristic Capacity							
	Grade 5.8 Steel Studs		Grade 8.8 Steel Studs		ANSI 316 Stainless Steel Studs		HCR 1.4529 Stainless Steel Studs	
	Shear, V _{Rd,seis} (kN)##	Tension, N _{Rd,seis} (kN)***	Shear, V _{Rd,seis} (kN)##	Tension, N _{Rd,seis} (kN)***	Shear, V _{Rd,seis} (kN)##	Tension, N _{Rd,seis} (kN)***	Shear, V _{Rd,seis} (kN)##	Tension, N _{Rd,seis} (kN)***
	C1 #	C1	C1 #	C1	C1	C1	C1	C1
M10	3.7	19.3	5.8	30.7	4.1	21.9	5.1	27.3
M12	5.4	28.0	8.5	44.7	6.0	31.6	7.5	39.3
M16	8.8	52.7	13.9	84.0	9.8	58.8	12.2	73.3
M20	13.6	82.0	21.8	130.7	15.3	92.0	19.0	114.7
M24	11.9	118.0	19.0	188.0	13.3	132.1	16.7	164.7
M30	19.0	187.3	30.6	299.3	21.5	210.2	26.9	262.0

***Note: Seismic Cracked Concrete steel resistance, tension = N_{Rd,s,seis} = α_{Nseis} N^o_{Rk,s,seis} / γ_{Ms} (kN) where γ_{Ms} = 1.5 (Grade 5.8 & 8.8 steel),

γ_{Ms} = 1.87 (A4 316 SS) and γ_{Ms} = 1.5 (HCR 1.4529 stainless steel)

Note: HOT-DIP GALVANIZED ANCHORS - for Seismic C1 reduced characteristic steel shear capacity the following reduction factors shall apply;

- M10 Multiply V_{Rd,seis} *0.47
- M12 Multiply V_{Rd,seis} *0.47
- M16 Multiply V_{Rd,seis} *0.54
- M20 Multiply V_{Rd,seis} *0.54
- M24 Multiply V_{Rd,seis} *0.88
- M30 Multiply V_{Rd,seis} *0.88

Note: Shear Data includes annular gap reduction factor of 0.5

For optimised performance data, please use Ramset iExpert Anchoring Software.

DESCRIPTION AND PART NUMBERS

Description	Cartridge Size	Part No.
EPCON C6 PLUS	600ml	EC6P600

ENGINEERING PROPERTIES ChemSet™ Anchor Studs and Threaded Rod

Anchor Size, d _b	Grade 8.8 Threaded Rod				Stainless Steel High Corrosion Resistance HCR Grade 1.4529/1.4565 Threaded Rod				Section modulus Z (mm ³)
	Shank diameter, d _s (mm)	Stressed Area (mm ²)	Yield Strength f _y MPa	UTS f _u MPa	Shank diameter, d _s (mm)	Stressed Area (mm ²)	Yield Strength f _y MPa	UTS f _u MPa	
M10	8.6	58	640	800	8.2	52.8	450	650	62.3
M12	10.4	84.3	640	800	10	78.5	450	650	109.2
M16	14.1	157	640	800	14	153.9	450	650	277.5
M20	17.7	245	640	800	17.2	232.4	450	650	540.9
M24	21.2	353	640	800	20.7	336.5	450	650	935.5
M30	26.7	561	640	800	-	-	-	-	-

Refer to "Engineering Properties" for ChemSet™ Anchor Studs Grade 5.8 and AISI 316 Stainless Steel in the SARB ANZ on page 141.

EPCON™ C6 PLUS

STRENGTH LIMIT STATE DESIGN

AVAILABLE IN NEW ZEALAND ONLY

STEP 1 Select anchor to be evaluated

Table 1a Indicative combined loading - interaction diagram

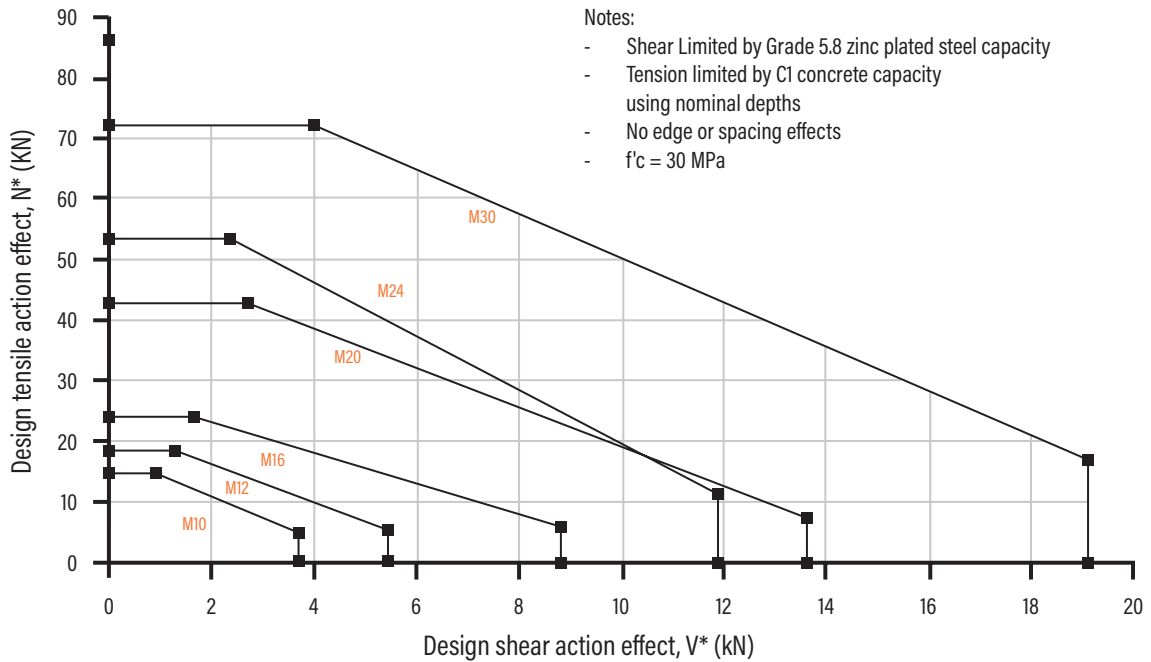

Table 1b Absolute minimum edge distance and anchor spacing values, e_m and a_m (mm)

Anchor size, d_h , M10	M10	M12	M16	M20	M24	M30
Min. Anchor Spacing - a_m	40	40	40	50	50	60
Min. Edge Distance - e_m	40	40	40	50	50	60

Step 1c Calculate anchor effective depth, h (mm)

Refer to "Description and Part Numbers" table for ChemSet® Anchor Studs page in the SARB ANZ on page 141.

Effective depth, h (mm)

Preferred $h = h_n$ otherwise,

$h = L_e - t$

t = total thickness of material(s) being fastened.

Substrate thickness b_m (mm)		
Anchor Stud Size (mm)		
M10	M12	M16 to M24
$h + 30\text{mm} \geq 100\text{mm}$		$h + (2 \times d_h)$

Checkpoint 1 Anchor size determined, absolute minima compliance achieved, effective depth (h) calculated.

EPCON™ C6 PLUS

STRENGTH LIMIT STATE DESIGN

AVAILABLE IN NEW ZEALAND ONLY

Seismic Anchors - EPCON™ C6 PLUS- Anchor Studs

STEP 2 Verify Seismic C1 cracked concrete tensile capacity - per anchor

Table 2a - Seismic (C1) Cracked concrete combined Pull-out and concrete cone resistance, tension

$$N_{Rd,p,seis}^0 = \alpha_{seis} N_{Rk,p,seis}^0 / \gamma_{Msp} \text{ (kN)}, \gamma_{Msp} = 1.5, \alpha_{N,seis} = 0.85, f'c = 30 \text{ MPa}$$

$$\text{where } N_{Rk,p,seis}^0 = \pi * d_b * h * \tau_{Rk,cr,seis}$$

Anchor Size, d_b	C1 Seismic Data					
	M10	M12	M16	M20	M24	M30
Drilled Hole Dia, d_h (mm)	12	14	18	22	26	35
Effective Depth, h (mm)						
70	11.0					
80	12.6					
90	14.2	15.2				
100	15.7	16.9				
110	17.3	18.6	21.5			
120	18.9	20.3	23.5			
125	19.7	21.1	24.4			
140	22.0	23.6	27.4			
150	23.6	25.3	29.3	37.0		
160	25.2	27.0	31.3	39.5		
170	26.8	28.7	33.2	41.9	43.6	
180	28.3	30.4	35.2	44.4	46.2	
190	29.9	32.1	37.1	46.9	48.8	
200	31.5	33.8	39.1	49.3	51.3	
210		35.5	41.1	51.8	53.9	54.3
240		40.5	46.9	59.2	61.6	62.1
280			54.7	69.1	71.9	72.4
320			62.6	78.9	82.1	82.7
350				86.3	89.8	90.5
400				98.6	102.6	103.4
450					115.5	116.3
480					123.2	124.1
550						142.2
600						155.1

Bold values are at ChemSet Anchors Stud nominal depths

All data relevant for Dry, Wet and Flooded Holes

For single anchor values: Multiply $N_{Rd,p,seis}^0 * 1.17$

For optimised performance data, please use Ramset iExpert Anchoring Software.

Table 2b-1 Seismic Cracked concrete service temperature limits effect, tension, X_{ns}

Anchor size, d_b	Service temperature limits effect, tension,					
	M10	M12	M16	M20	M24	M30
Service temperature (°C)						
-40 °C to +70 °C				1.00		

Table 2b-2 Seismic Cracked concrete compressive strength effect, tension, X_{nc}

$f'c$ (MPa)	20	25	30	40	50
X_{nc}	0.96	0.98	1.00	1.029	1.048

EPCON™ C6 PLUS

STRENGTH LIMIT STATE DESIGN

AVAILABLE IN NEW ZEALAND ONLY

Seismic Anchors - EPCON™ C6 PLUS - Anchor Studs

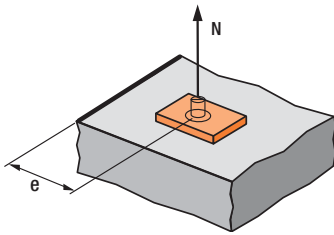

$X_{ne} = 0.25 + 0.5*(e/h)$
 Where $e_m \leq e \leq e_c$
 $e_c = 1.5*h$
 Note: Tabled values are based on the nominal effective depth, h shown in the installation details.
 For other values of X_{ne} , please use equation shown above.

Table 2c - Seismic cracked concrete Edge distance effect, tension, X_{ne}

Anchor size, d _b	M10	M12	M16	M20	M24	M30
Edge distance, e (mm)						
40	0.47	0.43	0.41			
45	0.50	0.45	0.43			
50	0.53	0.48	0.45	0.40	0.37	
55	0.56	0.50	0.47	0.41	0.38	
60	0.58	0.52	0.49	0.43	0.39	0.36
65	0.61	0.55	0.51	0.44	0.40	0.37
70	0.64	0.57	0.53	0.46	0.42	0.38
80	0.69	0.61	0.57	0.49	0.44	0.39
100	0.81	0.70	0.65	0.54	0.49	0.43
115	0.89	0.77	0.71	0.59	0.52	0.46
135	1.00	0.86	0.79	0.65	0.57	0.49
165		1.00	0.91	0.74	0.64	0.54
187			1.00	0.80	0.70	0.58
255				1.00	0.86	0.71
315					1.00	0.81
420						1.00

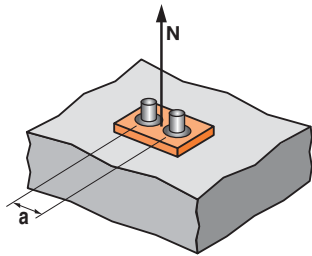

$X_{na} = 0.5 + a/(6*h)$
 Where $a_m \leq a \leq a_c$
 $a_c = 3*h$
 Note: Tabled values are based on the nominal effective depth, h shown in the installation details.
 For other values X_{na} , please use equation shown above.

Table 2d - Seismic cracked concrete anchor spacing effect, tension, X_{na}

Anchor size, d _b	M10	M12	M16	M20	M24	M30
Anchor spacing, a (mm)						
40	0.57	0.56	0.55			
45	0.58	0.57	0.56			
50	0.59	0.58	0.57	0.55	0.54	
55	0.60	0.58	0.57	0.55	0.54	
60	0.61	0.59	0.58	0.56	0.55	0.54
65	0.62	0.60	0.59	0.56	0.55	0.54
85	0.66	0.63	0.61	0.58	0.57	0.55
100	0.69	0.65	0.63	0.60	0.58	0.56
125	0.73	0.69	0.67	0.62	0.60	0.57
150	0.78	0.73	0.70	0.65	0.62	0.59
200	0.87	0.80	0.77	0.70	0.66	0.62
270	1.00	0.91	0.86	0.76	0.71	0.66
330		1.00	0.94	0.82	0.76	0.70
375			1.00	0.87	0.80	0.72
510				1.00	0.90	0.80
630					1.00	0.88
840						1.00

Checkpoint 2

Design seismic cracked concrete combined pull-out and concrete cone resistance, $N_{Rd,p,seis}$
 $N_{Rd,p,seis} = N_{Rd,p,seis}^0 * X_{ns} * X_{nc} * X_{ne} * X_{na}$

STEP 3

Verify seismic C1 cracked concrete tensile resistance - per anchor

Table 3a - Seismic C1 Cracked Concrete steel resistance, tensile, $N_{Rd,s,seis} = \alpha_{seis} N_{Rk,s,seis} / \gamma_{Ms}$ (kN), $\alpha_{seis} = 1.0$
 $\gamma_{Ms} = 1.5$ for Grade 5.8 and Grade 8.8 Carbon Steel
 $\gamma_{Ms} = 1.87$ for A4 316 Stainless Steel
 $\gamma_{Ms} = 1.5$ for HCR Stainless Steel

Anchor size, d _b	M10	M12	M16	M20	M24	M30
Grade 5.8 Carbon Steel	19.3	28.0	52.7	82.0	118.0	187.3
Grade 8.8 Carbon Steel	30.7	44.7	84.0	130.7	188.0	299.3
A4 316 Stainless Steel	21.9	31.6	58.8	92.0	132.1	210.2
HCR 1.4529 Stainless Steel	27.3	39.3	73.3	114.7	164.7	262.2

Checkpoint 3

Design seismic C1 cracked concrete tensile resistance, $N_{Rd,seis}$
 $N_{Rd,seis} = \text{minimum of } N_{Rd,p,seis}, N_{Rd,s,seis}$
 Check $N^*/N_{Rd,seis} \leq 1$,
 if not satisfied return to step 1

EPCON™ C6 PLUS

STRENGTH LIMIT STATE DESIGN

AVAILABLE IN NEW ZEALAND ONLY

Seismic Anchors - EPCON™ C6 PLUS- Anchor Studs

STEP 4

Step 4 - Verify seismic C1 cracked concrete edge shear resistance - per anchor

Table 4a - Seismic (C1) cracked concrete edge resistance, $V_{Rd,c,seis}^0 = \alpha_{seis} V_{Rk,c,seis}^0 / \gamma_{Mc}$ (kN), $\gamma_{Mc} = 1.5$, $\alpha_{seis} = 0.85$, $f'_c = 30$ MPa

Anchor size, d_b	M10	M12	M16	M20	M24	M30
Effective depth, h (mm)	90	110	125	170	210	280
Edge distance, e_m						
40	1.3	1.5	1.6			
50				2.5	2.8	
60						4.2

Note: Data includes annular gap reduction factor of 0.5.

For single anchor values: Multiply $V_{Rd,c,seis}^0$ * 1.17

For optimised performance data, please use Ramset iExpert Anchoring Software.

Table 4b - Seismic cracked concrete compressive strength effect, shear, X_{vc}

f'_c (MPa)	20	25	30	40	50
X_{vc}	0.82	0.91	1.00	1.15	1.29

Table 4c - Seismic cracked concrete load direction effect, concrete edge shear, X_{vd}

Angle, α°	0-55	60	70	80	90-180
X_{vd}	1	1.1	1.2	1.5	2

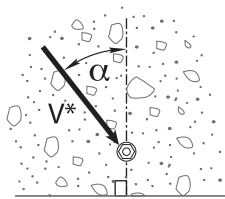

Load direction effect, conc. edge shear, X_{vd}

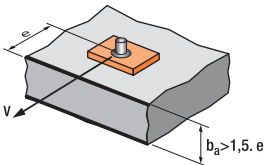

Table 4d - Seismic cracked concrete anchor spacing and edge distance effect, concrete edge shear, X_{ve}

For single anchor fastening X_{ve}

e/e_m	1.0	1.2	1.4	1.6	1.8	2.0	2.2	2.4	2.6	2.8	3.0	3.2
X_{ve}	1.00	1.31	1.66	2.02	2.41	2.83	3.26	3.72	4.19	4.69	5.20	5.72

$$X_{ve} = e/e_m * \sqrt{e/e_m}$$

For 2 anchors fastening X_{ve}

e/e_m	1.0	1.2	1.4	1.6	1.8	2.0	2.2	2.4	2.6	2.8	3.0	3.2
a/e_m												
1.0	0.67	0.84	1.03	1.22	1.43	1.65	1.88	2.12	2.36	2.62	2.89	3.16
1.5	0.75	0.93	1.12	1.33	1.54	1.77	2.00	2.25	2.50	2.76	3.03	3.31
2.0	0.83	1.02	1.22	1.43	1.65	1.89	2.12	2.38	2.63	2.90	3.18	3.46
2.5	0.92	1.11	1.32	1.54	1.77	2.00	2.25	2.50	2.77	3.04	3.32	3.61
3.0	1.00	1.20	1.42	1.64	1.88	2.12	2.37	2.63	2.90	3.18	3.46	3.76
3.5		1.30	1.52	1.75	1.99	2.24	2.50	2.76	3.04	3.32	3.61	3.91
4.0			1.62	1.86	2.10	2.36	2.62	2.89	3.17	3.46	3.75	4.05
4.5				1.96	2.21	2.47	2.74	3.02	3.31	3.60	3.90	4.20
5.0					2.33	2.59	2.87	3.15	3.44	3.74	4.04	4.35
5.5						2.71	2.99	3.28	3.71	4.02	4.33	4.65
6.0							2.83	3.11	3.41	3.71	4.02	4.33

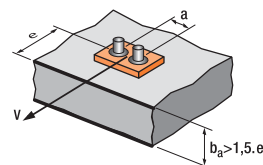

$$X_{ve} = \frac{3*e+a}{6*e_m} * \sqrt{e/e_m}$$

For 3 anchors fastening and more

$$X_{ve} = \frac{3*e + a_1 + a_2 + a_3 + \dots + a_{n-1}}{3*n*e_m} * \sqrt{e/e_m}$$

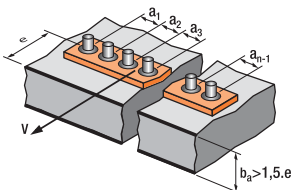

EPCON™ C6 PLUS

STRENGTH LIMIT STATE DESIGN

AVAILABLE IN NEW ZEALAND ONLY

Seismic Anchors - EPCON™ C6 PLUS - Anchor Studs

Table 4e - Seismic (C1) Cracked concrete Pryout failure, $V_{Rd,cp,seis}^0 = \alpha_{seis} V_{Rk,cp} / \gamma_{Mpr}$ (kN), $\gamma_{Mpr} = 1.5$,

$\alpha_{seis} = 0.75, f'_c = 30$ Mpa

Anchor size, d_b	M10	M12	M16	M20	M24	M30
Effective depth, h (mm)	90	110	125	170	210	280
C1 Seismic Data	12.5	16.4	21.6	37.0	47.5	63.9

Note: Data includes annular gap reduction factor of 0.5

For single anchor values: Multiply $V_{Rd,cp,seis}^0$ *1.13

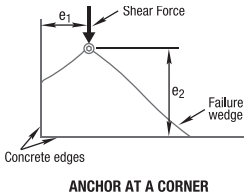

Table 4f Anchor at a corner effect, concrete edge shear, X_{Vs}

Note: For $e_1/e_2 > 1.25, X_{Vs} = 1.0$

Edge distance, e_2 (mm)	25	30	35	50	60	75	125	200	300	400	600	900
Edge distance, e_1 (mm)												
25	0.86	0.77	0.70	0.58	0.53	0.49	0.41	0.37	0.35	0.34	0.32	0.32
30	0.97	0.86	0.78	0.64	0.58	0.52	0.43	0.38	0.36	0.34	0.33	0.32
35	1.00	0.95	0.86	0.69	0.63	0.56	0.46	0.40	0.37	0.35	0.33	0.32
50	1.00	1.00	1.00	0.86	0.77	0.67	0.52	0.44	0.39	0.37	0.35	0.33
60	1.00	1.00	1.00	0.97	0.86	0.75	0.57	0.47	0.41	0.38	0.36	0.34
75	1.00	1.00	1.00	1.00	1.00	0.86	0.64	0.51	0.44	0.41	0.37	0.35
125	1.00	1.00	1.00	1.00	1.00	1.00	0.86	0.65	0.53	0.48	0.42	0.38
200	1.00	1.00	1.00	1.00	1.00	1.00	1.00	0.86	0.67	0.58	0.49	0.42
300	1.00	1.00	1.00	1.00	1.00	1.00	1.00	1.00	0.86	0.72	0.58	0.49
400	1.00	1.00	1.00	1.00	1.00	1.00	1.00	1.00	1.00	0.86	0.67	0.55
500	1.00	1.00	1.00	1.00	1.00	1.00	1.00	1.00	1.00	1.00	0.77	0.61
600	1.00	1.00	1.00	1.00	1.00	1.00	1.00	1.00	1.00	1.00	0.86	0.67
900	1.00	1.00	1.00	1.00	1.00	1.00	1.00	1.00	1.00	1.00	1.00	0.86

Checkpoint 4a

Design seismic cracked concrete edge shear resistance, $V_{Rd,c,seis}$
 $= V_{Rd,c,seis}^0 * X_{vc} * X_{vd} * X_{ve} * X_{vs}$

Checkpoint 4b

Design seismic cracked concrete Pryout failure,
 $V_{Rd,cp,seis} = V_{Rd,cp,seis}^0 * X_{nc} * X_{ne} * X_{na}$

STEP 5

Verify seismic C1 cracked concrete shear resistance - per anchor

Table 5a - Seismic (C1) Cracked Concrete steel shear resistance, $V_{Rd,s,seis} = \alpha_{seis} V_{Rk,s,seis} / \gamma_{Ms}$ (kN), $\alpha_{seis} = 0.85$

$\gamma_{Ms} = 1.25$ for Grade 5.8 and Grade 8.8 Carbon Steel

$\gamma_{Ms} = 1.56$ for A4 316 Stainless Steel

$\gamma_{Ms} = 1.25$ for HCR 1.4529 Stainless Steel

Anchor size, d_b		C1 Seismic Data					
		M10	M12	M16	M20	M24	M30
Grade 5.8	Zinc Plated Steel	3.7	5.4	8.8	13.6	11.9	19.0
	Hot Dip Galv. Steel	1.8	2.6	4.8	7.3	10.5	16.8
Grade 8.8	Zinc Plated Steel	5.8	8.5	13.9	21.8	19.0	30.6
	Hot Dip Galv. Steel	2.7	4.0	7.5	11.8	16.8	26.9
A4 316	Stainless Steel	4.1	6.0	9.8	15.3	13.3	21.5
HCR 1.4529	Stainless Steel	5.1	7.5	12.2	19.0	16.7	26.9

Note: Data includes annular gap reduction factor of 0.5

For single anchor values: Multiply $V_{Rd,s,seis}$ *1.17

Checkpoint 5

Design seismic C1 cracked concrete shear resistance, $V_{Rd,seis}$
 $V_{Rd,seis} = \text{minimum of } V_{Rd,c,seis}, V_{Rd,cp,seis}, V_{Rd,s,seis}$
 Check $V^*/V_{Rd,seis} \leq 1$,
 if not satisfied return to step 1

EPCON™ C6 PLUS

STRENGTH LIMIT STATE DESIGN

AVAILABLE IN NEW ZEALAND ONLY

Seismic Anchors - EPCON™ C6 PLUS- Anchor Studs

STEP 6 Combined Loading

Checkpoint 6 **Check**

$$N^*/N_{Rd,seis} + V^*/V_{Rd,seis} \leq 1.0,$$

if not satisfied return to step 1

Specify - Threaded Stud Anchors
 Ramset™ EPCON™ C6 PLUS with (Anchor Size) grade 5.8 ChemSet™ Anchor Stud (Anchor Stud Part Number) Drilled Hole Depth to be (h) mm.

Example
 Ramset™ EPCON™ C6 PLUS Injection with M16 grade 5.8 ChemSet™ Anchor Stud (CS16190GH). Drilled hole depth to be 125mm. To be installed according to Ramset™ Installation Instructions.

Use Ramset™ iExpert Anchor Software for optimised calculation or where a greater range of anchor layout detail is needed.

EPCON™ C6 PLUS

SEISMIC REINFORCING BAR - CHEMICAL INJECTION

Back to index

AVAILABLE IN NEW ZEALAND ONLY

(Australia refer to ChemSet™ Reo502™ PLUS range)

GENERAL INFORMATION

Performance Related



Installation Related



Product

EPCON™ C6 PLUS is a heavy duty pure Epoxy for anchoring threaded studs and reinforcing bar into cracked and uncracked concrete.

Compliance

European Technical Assessment (option 1) - ETA-18/0675

Design according to:

- AS1170.4 - Earthquake Actions
- EN1992-4 (formerly ETAG001 Annex C, E & TR045)
- NZS3101 (A3) Section 17 - Seismic Design C1
- Use enclosed data for simplified calculation method

Use Ramset™ iExpert Anchor Software for optimised calculation or where a greater range of anchor layout detail is needed.

Benefits, Advantages and Features

- 100 year working life

Greater productivity:

- Anchors in dry, damp, wet or flooded holes
- Easy dispensing even in cold weather

Greater security:

- Strong bond
- Rated for sustained loading

Versatile:

- Anchors in carbide drilled and diamond drilled holes*
- Cold and temperate climates

Greater safety:

- Low odour
- VOC Compliant

Installation

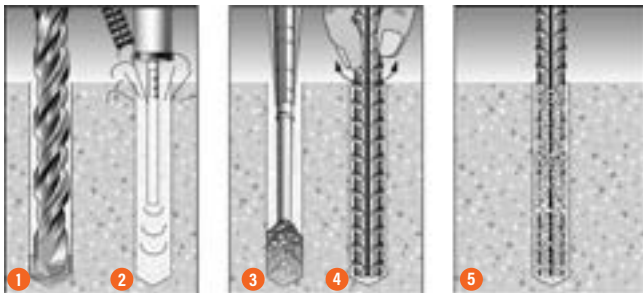

1. Drill recommended diameter and depth hole.
2. **Important:** Use Ramset™ Dustless Drilling System to ensure holes are clean. Alternatively, clean dust and debris from hole with stiff wire or nylon brush and blower in the following sequence: blow x 2, brush x 2, blow x 2, brush x 2, blow x 2.
3. Dispense adhesive to waste until colour is uniform light grey (2-3 trigger pulls). Insert mixing nozzle to bottom of hole. Fill hole to 3/4 the hole depth slowly, ensuring no air pockets form.
4. Insert Ramset™ ChemSet™ Anchor Stud/rebar to bottom of hole while turning.
5. Allow EPCON™ C6 PLUS to cure as per setting times.



Principal Applications

- Threaded Studs
- Starter Bars
- Threaded Inserts
- Over-head installation
- Steel Columns
- Hand Rails
- Road Stitching

Recommended Installation Temperatures

	Minimum	Maximum
Substrate	5°C	40°C
Adhesive	10°C	40°C

Service Temperature Limits

-40°C to 70°C

Setting Times

Temperature of base material	Cartridge Temperature	Gel Time	Curing time in dry and wet concrete
5°C	Minimum 10°C	300 min	24 h
10°C	10°C	150 min	18 h
15°C	15°C	40 min	12 h
20°C	20°C	25 min	8 h
25°C	25°C	18 min	6 h
30°C	30°C	12 min	4 h
40°C	40°C	6 min	2 h

Note: Cartridge temperature minimum +10°C

Note

*Performance of cored & oversized holes was not included in the ETAG test program and therefore is based on testing conducted at Ramset™ Product Engineering Laboratory.

Seismic Anchors - EPCON™ C6 PLUS- Reinforcing Bar

EPCON™ C6 PLUS

SEISMIC REINFORCING BAR - CHEMICAL INJECTION

AVAILABLE IN NEW ZEALAND ONLY

Installation and performance details: EPCON™ C6 Plus and ChemSet™ Reinforcing Bar

Rebar size, d _b (mm)	Drilled hole diameter, d _h (mm)	Anchor effective depth, h (mm)	Optimum dimensions*		Concrete substrate thickness, b _m (mm)	Gr 500 Rebar - Steel		Seismic (C1) Cracked Concrete reduced characteristic tensile capacity, N ⁰ _{Rd,p,seis} (kN) **		
			Anchor* spacing, a _c (mm)	Edge* distance, e _c (mm)		Tension, φN _{us} (kN)***	Shear, φV _{us} (kN)	Concrete Compressive Strength, f'c		
								20 MPa	30 Mpa	40 Mpa
10	14	90	270	135	120	30.7	10.7	13.6	14.2	14.6
12	16	110	330	165	140	44.3	15.3	17.9	18.6	19.1
16	20	125	375	187.5	165	79.3	27.3	23.5	24.4	25.1
20	25	170	510	255	220	123.6	46.0	40.3	41.9	43.1
25	32	210	630	315	274	192.9	41.2	51.8	53.9	55.4
32	40	300	900	450	380	315.7	74.0	74.6	77.6	79.8

* For anchor spacings or edge distances less than the minimum, please refer to the simplified strength limit state design process to verify capacity.

** Seismic Cracked concrete combined pull-out and concrete cone resistance, tension = N⁰_{Rd,p,seis} = α_{Nseis} N⁰_{Rk,p,seis} / γ_{Msp} where γ_{Msp} = 1.5

*** Seismic Cracked concrete steel resistance, tension = N_{Rd,s,seis} = α_{Nseis} N⁰_{Rk,s,seis} / γ_{Ms} (kN) where γ_{Ms} = 1.4

For optimised performance data, please use Ramset iExpert Anchoring Software.

DESCRIPTION AND PART NUMBERS

Description	Cartridge Size	Part No.
EPCON C6 PLUS	600ml	EC6P600

Drilled hole depth, h ₁ (mm) h ₁ = h h = Effective depth	Substrate thickness b _m (mm)					
	Anchor Stud Size (mm)					
	10	12	16	20	25	32
	h + 30mm ≥ 100mm			h + (2 x d _h)		

Typical Engineering Properties of Grade 500 Reinforcing Bar

Rebar Size	10	12	16	20	25	32
Drilled Hole Dia, d _h (mm)	14	16	20	25	32	40
Stress Area, A _s (mm ²)	78.5	113	201	314	491	804
Yield Stress, f _{sy} (MPa)	500	500	500	500	500	500
Tensile Steel Yield Capacity, N _{sy} (kN)	39.3	56.5	100.5	157.0	245.5	402.0

For further information refer to reinforcing bar manufacturer's published information and current revision of AS/NZS 4671

EPCON™ C6 PLUS

SEISMIC REINFORCING BAR - CHEMICAL INJECTION

AVAILABLE IN NEW ZEALAND ONLY

Seismic Anchors - EPCON™ C6 PLUS- Reinforcing Bar

STEP 1

Select anchor to be evaluated

Table 1a Indicative combined loading - interaction diagram

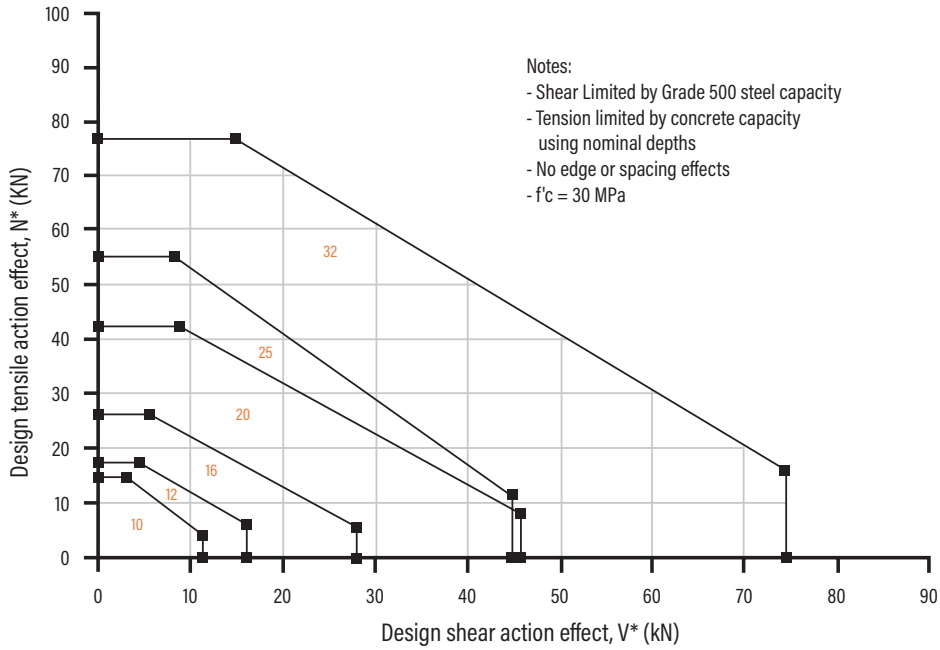

Table 1b Absolute minimum edge distance and anchor spacing values, e_m and a_m (mm)

Anchor size, d_b M10	10	12	16	20	25	32
Min. Anchor Spacing - a_m	40	40	40	50	50	70
Min. Edge Distance - e_m	40	40	40	50	50	70

Step 1c Calculate anchor effective depth, h (mm)

Refer to nominal recommended effective depths, h listed in installation and performance details in the SARB ANZ on the previous page.

Substrate thickness b_m (mm)					
Anchor Stud Size (mm)					
10	12	16	20	25	32
$h + 30\text{mm} \geq 100\text{mm}$			$h + (2 \times d_h)$		

Checkpoint 1

Anchor size determined, absolute minima compliance achieved, effective depth (h) calculated.

EPCON™ C6 PLUS

STRENGTH LIMIT STATE DESIGN

AVAILABLE IN NEW ZEALAND ONLY

Seismic Anchors - EPCON™ C6 PLUS- Reinforcing Bar

STEP 2 Verify Seismic C1 cracked concrete tensile capacity - per anchor

Table 2a - Seismic (C1) Cracked concrete combined Pull-out and concrete cone resistance, tension

$$N_{Rd,p,seis}^0 = \alpha_{seis} N_{Rk,p,seis}^0 / \gamma_{Msp} \text{ (kN)}, \gamma_{Msp} = 1.5, \alpha_{N,seis} = 0.85, f'c = 30 \text{ MPa, where } N_{Rk,p,seis}^0 = \pi * d_b * h * \tau_{Rk,cr,seis}$$

Anchor Size, db	10	12	16	20	25	32
Drilled Hole Dia, dh (mm)	14	16	20	25	32	40
Effective Depth, h (mm)						
70	11.0					
80	12.6					
90	14.2	15.2				
100	15.8	16.9				
110	17.3	18.6	21.5			
120	18.9	20.3	23.5			
125	19.7	21.1	24.4			
140	22.1	23.6	27.4			
150	23.6	25.3	29.3	37.0		
160	25.2	27.0	31.3	39.5		
170	26.8	28.7	33.2	41.9	43.6	
180	28.4	30.4	35.2	44.4	46.2	
190	29.9	32.1	37.1	46.9	48.8	
200	31.5	33.8	39.1	49.3	51.3	
210		35.5	41.0	51.8	53.9	54.3
240		40.5	46.9	59.2	61.6	62.1
300			58.6	74.0	77.0	77.6
320			62.5	78.9	82.1	82.7
350				86.3	89.8	90.5
400				98.7	102.6	103.4
450					115.5	116.3
480					123.2	124.1
550						142.2
600						155.1

Bold values are at ChemSet Rebar Anchor nominal depths

Flooded Holes: Multiply $N_{Rd,p,seis}^0$ * 0.83

For single anchor values: Multiply $N_{Rd,p,seis}^0$ *1.17

For optimised performance data, please use Ramset iExpert Anchoring Software.

Table 2b-1 Seismic Cracked concrete service temperature limits effect, tension, X_{ns}

Anchor size, db	Service temperature limits effect, tension, X_{ns}					
	10	12	16	20	25	32
Service temperature (°C)						
-40 °C to +70 °C	1.00					

Table 2b-2 Seismic Cracked concrete compressive strength effect, tension, X_{nc}

f'c (MPa)	20	25	30	40	50
X_{nc}	0.96	0.98	1.00	1.029	1.048

EPCON™ C6 PLUS

STRENGTH LIMIT STATE DESIGN

AVAILABLE IN NEW ZEALAND ONLY

Seismic Anchors - EPCON™ C6 PLUS - Reinforcing Bar

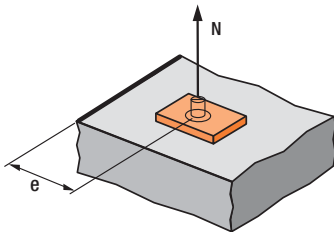

$$X_{ne} = 0.25 + 0.5 \cdot (e/h)$$

Where $e_m \leq e \leq e_c$

$$e_c = 1.5 \cdot h$$

Note: Tabled values are based on the nominal effective depth, h shown in the installation details. For other values of X_{ne} , please use equation shown above.

Table 2c - Seismic cracked concrete Edge distance effect, tension, X_{ne}

Anchor size, d_n	10	12	16	20	25	32
Edge distance, e (mm)						
40	0.47	0.43	0.41			
45	0.50	0.45	0.43			
50	0.53	0.48	0.45	0.40	0.37	
55	0.56	0.50	0.47	0.41	0.38	
60	0.58	0.52	0.49	0.43	0.39	
65	0.61	0.55	0.51	0.44	0.40	
70	0.64	0.57	0.53	0.46	0.42	0.37
80	0.69	0.61	0.57	0.49	0.44	0.38
100	0.81	0.70	0.65	0.54	0.49	0.42
115	0.89	0.77	0.71	0.59	0.52	0.44
135	1	0.86	0.79	0.65	0.57	0.48
165		1	0.91	0.74	0.64	0.53
187			1	0.80	0.70	0.56
255				1	0.86	0.68
315					1	0.78
420						1

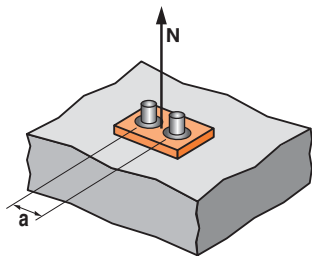

$$X_{na} = 0.5 + a/(6 \cdot h)$$

Where $a_m \leq a \leq a_c$

$$a_c = 3 \cdot h$$

Note: Tabled values are based on the nominal effective depth, h shown in the installation details. For other values X_{na} , please use equation shown above.

Table 2d - Seismic cracked concrete anchor spacing effect, tension, X_{na}

Anchor size, d_n	10	12	16	20	25	32
Anchor spacing, a (mm)						
40	0.57	0.56	0.55			
45	0.58	0.57	0.56			
50	0.59	0.58	0.57	0.55	0.54	
55	0.60	0.58	0.57	0.55	0.54	
60	0.61	0.59	0.58	0.56	0.55	
65	0.62	0.60	0.59	0.56	0.55	
70	0.63	0.61	0.59	0.57	0.56	0.54
100	0.69	0.65	0.63	0.60	0.58	0.56
125	0.73	0.69	0.67	0.62	0.60	0.57
150	0.78	0.73	0.70	0.65	0.62	0.58
200	0.87	0.80	0.77	0.70	0.66	0.61
270	1	0.91	0.86	0.76	0.71	0.65
330		1	0.94	0.82	0.76	0.68
375			1	0.87	0.80	0.71
510				1	0.90	0.78
630					1	0.85
840						1

Checkpoint

2

Design seismic cracked concrete combined pull-out and concrete cone resistance, $N_{Rd,p,seis}$

$$N_{Rd,p,seis} = N_{Rd,p,seis}^0 * X_{ns} * X_{nc} * X_{ne} * X_{na}$$

STEP

3

Verify seismic C1 cracked concrete tensile resistance - per anchor

Table 3a - Seismic C1 Cracked Concrete steel resistance, tensile, $N_{Rd,s,seis} = \alpha_{seis} N_{Rk,s,seis} / \gamma_{Ms}$ (kN) where $\alpha_{seis} = 1.0, \gamma_{Ms} = 1.4$ for Grade 500 Rebar

Anchor size, d_n	10	12	16	20	25	30
Rebar Gr 500	30.7	44.3	79.3	123.6	192.9	315.7

Checkpoint

3

Design seismic C1 cracked concrete tensile resistance, $N_{Rd,seis}$

$$N_{Rd,seis} = \text{minimum of } N_{Rd,p,seis}, N_{Rd,s,seis}$$

Check $N^*/N_{Rd,seis} \leq 1$,
if not satisfied return to step 1

EPCON™ C6 PLUS

STRENGTH LIMIT STATE DESIGN

AVAILABLE IN NEW ZEALAND ONLY

Seismic Anchors - EPCON™ C6 PLUS- Reinforcing Bar

STEP 4

Step 4 - Verify seismic C1 cracked concrete edge shear resistance - per anchor

Table 4a - Seismic cracked concrete edge resistance, $V_{Rd,c,seis}^0 = \alpha_{seis} V_{Rk,c,seis}^0 / \gamma_{Mc}$ (kN), $\gamma_{Mc} = 1.5$, $\alpha_{seis} = 0.85$, $f'_c = 30$ MPa

Anchor size, d_b	10	12	16	20	25	32
Effective depth, h (mm)	90	110	125	170	210	300
Edge distance, e_m						
40	2.7	2.9	3.3			
50				5.0	5.7	
70						10.3

For single anchor values: Multiply $V_{Rd,c,seis}^0$ *1.17
For optimised performance data, please use Ramset iExpert Anchoring Software.

Table 4b - Seismic cracked concrete compressive strength effect, shear, X_{vc}

f'_c (MPa)	20	25	30	40	50
X_{vc}	0.82	0.9	1	1.15	1.29

Table 4c - Seismic cracked concrete load direction effect, concrete edge shear, X_{vd}

Angle, α°	0-55	60	70	80	90-180
X_{vd}	1	1.1	1.2	1.5	2

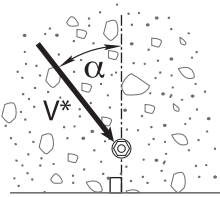

Load direction effect, conc. edge shear, X_{vd}

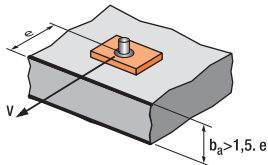
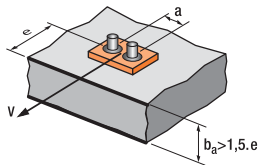

Table 4d - Seismic cracked concrete anchor spacing and edge distance effect, concrete edge shear, X_{ve}

For single anchor fastening X_{ve}

e/e_m	1.0	1.2	1.4	1.6	1.8	2.0	2.2	2.4	2.6	2.8	3.0	3.2
X_{ve}	1.00	1.31	1.66	2.02	2.41	2.83	3.26	3.72	4.19	4.69	5.20	5.72

$$X_{ve} = e/e_m * \sqrt{e/e_m}$$



For 2 anchors fastening X_{ve}

e/e_m	1.0	1.2	1.4	1.6	1.8	2.0	2.2	2.4	2.6	2.8	3.0	3.2
a/e_m												
1.0	0.67	0.84	1.03	1.22	1.43	1.65	1.88	2.12	2.36	2.62	2.89	3.16
1.5	0.75	0.93	1.12	1.33	1.54	1.77	2.00	2.25	2.50	2.76	3.03	3.31
2.0	0.83	1.02	1.22	1.43	1.65	1.89	2.12	2.38	2.63	2.90	3.18	3.46
2.5	0.92	1.11	1.32	1.54	1.77	2.00	2.25	2.50	2.77	3.04	3.32	3.61
3.0	1.00	1.20	1.42	1.64	1.88	2.12	2.37	2.63	2.90	3.18	3.46	3.76
3.5		1.30	1.52	1.75	1.99	2.24	2.50	2.76	3.04	3.32	3.61	3.91
4.0			1.62	1.86	2.10	2.36	2.62	2.89	3.17	3.46	3.75	4.05
4.5				1.96	2.21	2.47	2.74	3.02	3.31	3.60	3.90	4.20
5.0					2.33	2.59	2.87	3.15	3.44	3.74	4.04	4.35
5.5						2.71	2.99	3.28	3.71	4.02	4.33	4.65
6.0						2.83	3.11	3.41	3.71	4.02	4.33	4.65

$$X_{ve} = \frac{3 * e + a}{6 * e_m} * \sqrt{e/e_m}$$

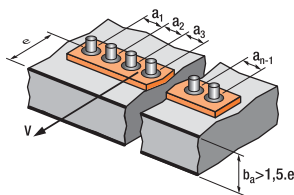

For 3 anchors fastening and more

$$X_{ve} = \frac{3 * e + a_1 + a_2 + a_3 + \dots + a_{n-1}}{3 * n * e_m} * \sqrt{e/e_m}$$

EPCON™ C6 PLUS

STRENGTH LIMIT STATE DESIGN

AVAILABLE IN NEW ZEALAND ONLY

Seismic Anchors - EPCON™ C6 PLUS- Reinforcing Bar

Table 4e - Seismic Cracked concrete Pryout failure,

$$V_{Rd,cp}^0 = \alpha_{seis} V_{Rk,cp} / \gamma_{Mpr} \text{ (kN)}, \gamma_{Mpr} = 1.5, \alpha_{seis} = 0.75, f'c = 30 \text{ Mpa}$$

Anchor size, d_b	10	12	16	20	25	32
Effective depth, h (mm)	90	110	125	170	210	300
-40°C to +70°C	25.5	32.8	43.1	74.0	95.1	136.9

For single anchor values: Multiply $V_{Rd,cp}^0 * 1.13$

Table 4f Anchor at a corner effect, concrete edge shear, X_{Vs}

Note: For $e_1/e_2 > 1.25$, $X_{Vs} = 1.0$

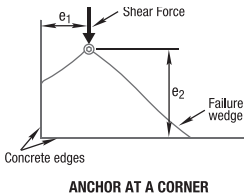

Edge distance, e_2 (mm)	25	30	35	50	60	75	125	200	300	400	600	900
Edge distance, e_1 (mm)												
25	0.86	0.77	0.70	0.58	0.53	0.49	0.41	0.37	0.35	0.34	0.32	0.32
30	0.97	0.86	0.78	0.64	0.58	0.52	0.43	0.38	0.36	0.34	0.33	0.32
35	1.00	0.95	0.86	0.69	0.63	0.56	0.46	0.40	0.37	0.35	0.33	0.32
50	1.00	1.00	1.00	0.86	0.77	0.67	0.52	0.44	0.39	0.37	0.35	0.33
60	1.00	1.00	1.00	0.97	0.86	0.75	0.57	0.47	0.41	0.38	0.36	0.34
75	1.00	1.00	1.00	1.00	1.00	0.86	0.64	0.51	0.44	0.41	0.37	0.35
125	1.00	1.00	1.00	1.00	1.00	1.00	0.86	0.65	0.53	0.48	0.42	0.38
200	1.00	1.00	1.00	1.00	1.00	1.00	1.00	0.86	0.67	0.58	0.49	0.42
300	1.00	1.00	1.00	1.00	1.00	1.00	1.00	1.00	0.86	0.72	0.58	0.49
400	1.00	1.00	1.00	1.00	1.00	1.00	1.00	1.00	1.00	0.86	0.67	0.55
500	1.00	1.00	1.00	1.00	1.00	1.00	1.00	1.00	1.00	1.00	0.77	0.61
600	1.00	1.00	1.00	1.00	1.00	1.00	1.00	1.00	1.00	1.00	0.86	0.67
900	1.00	1.00	1.00	1.00	1.00	1.00	1.00	1.00	1.00	1.00	1.00	0.86

Checkpoint **4a**

Design seismic cracked concrete edge shear resistance, $V_{Rd,c,seis}$
 $= V_{Rd,c,seis}^0 * X_{vc} * X_{vd} * X_{ve} * X_{vs}$

Checkpoint **4b**

Design seismic cracked concrete Pryout failure,
 $V_{Rd,cp,seis} = V_{Rd,cp,seis}^0 * X_{nc} * X_{ne} * X_{na}$

STEP **5**

Verify seismic C1 cracked concrete shear resistance - per anchor

Table 5a - Seismic (C1) Cracked Concrete steel shear resistance, $V_{Rd,s,seis} = \alpha_{seis} V_{Rk,s,seis} / \gamma_{Ms}$ (kN)

where $\alpha_{seis} = 1.0$ and $\gamma_{Ms} = 1.5$

Anchor size, d_b	C1 Seismic Data					
	10	20	16	20	25	32
Rebar Gr 500	10.7	15.3	27.3	46.0	44.7	74.0

Checkpoint **5**

Design seismic C1 cracked concrete shear resistance, $V_{Rd,seis}$

$$V_{Rd,seis} = \text{minimum of } V_{Rd,c,seis}, V_{Rd,cp,seis}, V_{Rd,s,seis}$$

Check $V / V_{Rd,seis} \leq 1$,
 if not satisfied return to step 1

EPCON™ C6 PLUS

STRENGTH LIMIT STATE DESIGN

AVAILABLE IN NEW ZEALAND ONLY

Seismic Anchors - EPCON™ C6 PLUS- Reinforcing Bar

STEP 6 Combined Loading

Checkpoint	6	<p>Check</p> $N^*/N_{Rd,seis} + V^*/V_{Rd,seis} \leq 1.0,$ <p>if not satisfied return to step 1</p>
-------------------	----------	--

Specify - Reinforcing Bar Anchorage

Ramset™ EPCON™ C6 PLUS Injection
(Anchor Size) grade 500 Rebar.
Drilled hole depth to be (h) mm.

Example

Ramset™ EPCON™ C6 PLUS Injection with
20mm grade 500 Rebar
Drilled hole depth to be 170 mm.
To be installed in accordance with
Ramset Installation Instructions.

Use Ramset™ iExpert Anchor Software for optimised calculation or where a greater range of anchor layout detail is needed.

ChemSet™ Reo 502™ PLUS

SEISMIC ANCHOR STUDS - CHEMICAL INJECTION

Back to index

AVAILABLE IN AUSTRALIA ONLY

(New Zealand refer to EPCON™ C6 PLUS range)

GENERAL INFORMATION

Performance Related	Material Specification	Installation Related

Product

ChemSet™ Reo 502™ PLUS is a heavy duty pure Epoxy for anchoring threaded studs and reinforcing bar into cracked and uncracked concrete.



Compliance

European Technical Assessment (option 1) - ETA-18/0675

Design according to:

- AS5216 (formerly TS101)
- AS1170.4 - Earthquake Actions
- EN1992-4 (formerly ETAG001 Annex C, E & TR045)
- Use enclosed data for simplified calculation method

Use Ramset™ iExpert Anchor Software for optimised calculation or where a greater range of anchor layout detail is needed.

Benefits, Advantages and Features

- 100 year working life
- Greater productivity:**
 - Anchors in dry, damp, wet or flooded holes
 - Easy dispensing even in cold weather
- Greater security:**
 - Strong bond
 - Rated for sustained loading
- Versatile:**
 - Anchors in carbide drilled and diamond drilled holes*
 - Cold and temperate climates
- Greater safety:**
 - Low odour
 - VOC Compliant
 - Suitable for contact with drinking water



Principal Applications

- Threaded Studs
- Starter Bars
- Threaded Inserts
- Over-head installation
- Steel Columns
- Hand Rails
- Road Stitching

Recommended Installation Temperatures

	Minimum	Maximum
Substrate	5°C	40°C
Adhesive	10°C	40°C

Service Temperature Limits

-40°C to 70°C

Setting Times

Temperature of base material	Cartridge Temperature	Gel Time	Curing time in dry and wet concrete
5°C	Minimum 10°C	300 min	24 h
10°C	10°C	150 min	18 h
15°C	15°C	40 min	12 h
20°C	20°C	25 min	8 h
25°C	25°C	18 min	6 h
30°C	30°C	12 min	4 h
40°C	40°C	6 min	2 h

Note: Cartridge temperature minimum +10°C

Note

*Performance of cored & oversized holes was not included in the ETAG test program and therefore is based on testing conducted at Ramset™ Product Engineering Laboratory.

Installation

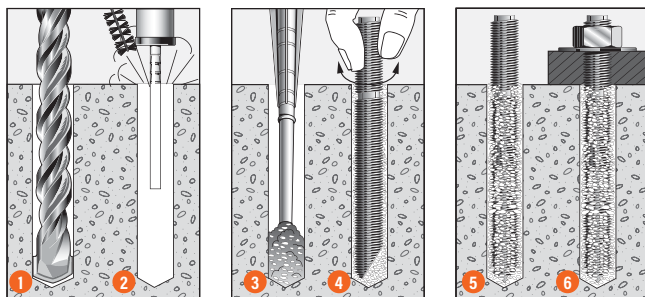

- Drill recommended diameter and depth hole.
- Important:** Use Ramset™ Dustless Drilling System to ensure holes are clean. Alternatively clean dust and debris from hole with stiff wire or nylon brush and blower in the following sequence: blow x 2, brush x 2, blow x 2, brush x 2, blow x 2.
- Dispense adhesive to waste until colour is uniform light grey (2-3 trigger pulls). Insert mixing nozzle to bottom of hole. Fill hole to 3/4 the hole depth slowly, ensuring no air pockets form.
- Insert Ramset™ ChemSet™ Anchor Stud/rebar to bottom of hole while turning.
- Allow ChemSet™ Reo 502™ PLUS to cure as per setting times.
- Attach fixture.

Seismic Anchors - ChemSet™ Reo 502™ PLUS - Anchor Studs

ChemSet™ Reo 502™ PLUS

SEISMIC ANCHOR STUDS - CHEMICAL INJECTION

AVAILABLE IN AUSTRALIA ONLY

Seismic Anchors - ChemSet™ Reo 502™ PLUS - Anchor Studs

Installation and performance details: ChemSet™ Reo 502™ PLUS and ChemSet™ Anchor Studs

Anchor size, d _b (mm)	Drilled hole diameter, d _h (mm)	Fixture hole diameter, d _f (mm)	Anchor effective depth, h (mm)	Tightening torque, T _i (Nm)	Optimum dimensions*		Concrete substrate thickness, b _m (mm)	Seismic C1 Cracked Concrete reduced characteristic tensile capacity, N ^o _{Rd,s,seis} (kN) **		
					Anchor* spacing, a _c (mm)	Edge* distance, e _c (mm)		Concrete Compressive Strength, f _c		
								20 MPa	30 MPa	40 MPa
								C1	C1	C1
M10	12	12	90	20	270	135	120	13.6	14.2	14.6
M12	14	14	110	40	330	165	140	17.9	18.6	19.1
M16	18	18	125	80	375	188	161	23.5	24.4	25.1
M20	22	22	170	120	510	255	214	40.3	41.9	43.1
M24	26	26	210	160	630	315	262	51.8	53.9	55.4
M30	35	33	280	200	840	420	350	69.6	72.4	74.5

* For anchor spacings or edge distances less than the minimum, please refer to the simplified strength limit state design process to verify capacity.

** Tension values are based on service temperature limits -40 °C to +70 °C only. If service temperature limits is beyond this range please contact Ramset Engineer.

*** Note: Seismic Cracked concrete combined pull-out and concrete cone resistance, tension = N^o_{Rd,s,seis} = α_{Nseis} N^o_{Rk,p,seis} / γ_{Msp} where γ_{Msp} = 1.5

Anchor size, d _b (mm)	Reduced Characteristic Capacity							
	Grade 5.8 Steel Studs		Grade 8.8 Steel Studs		ANSI 316 Stainless Steel Studs		HCR 1.4529 Stainless Steel Studs	
	Shear, V _{Rd,seis} (kN)##	Tension, N _{Rd,seis} (kN)***	Shear, V _{Rd,seis} (kN)##	Tension, N _{Rd,seis} (kN)***	Shear, V _{Rd,seis} (kN)##	Tension, N _{Rd,seis} (kN)***	Shear, V _{Rd,seis} (kN)##	Tension, N _{Rd,seis} (kN)***
	C1 #	C1	C1 #	C1	C1	C1	C1	C1
M10	3.7	19.3	5.8	30.7	4.1	21.9	5.1	27.3
M12	5.4	28.0	8.5	44.7	6.0	31.6	7.5	39.3
M16	8.8	52.7	13.9	84.0	9.8	58.8	12.2	73.3
M20	13.6	82.0	21.8	130.7	15.3	92.0	19.0	114.7
M24	11.9	118.0	19.0	188.0	13.3	132.1	16.7	164.7
M30	19.0	187.3	30.6	299.3	21.5	210.2	26.9	262.0

***Note: Seismic Cracked Concrete steel resistance, tension = N_{Rd,s,seis} = α_{Nseis} N^o_{Rk,s,seis} / γ_{Ms} (kN) where γ_{Ms} = 1.5 (Grade 5.8 & 8.8 steel),

γ_{Ms} = 1.87 (A4 316 SS) and γ_{Ms} = 1.5 (HCR 1.4529 stainless steel)

Note: HOT-DIP GALVANIZED ANCHORS - for Seismic C1 reduced characteristic steel shear capacity the following reduction factors shall apply;

- M10 Multiply V_{Rd,seis} *0.47
- M12 Multiply V_{Rd,seis} *0.47
- M16 Multiply V_{Rd,seis} *0.54
- M20 Multiply V_{Rd,seis} *0.54
- M24 Multiply V_{Rd,seis} *0.88
- M30 Multiply V_{Rd,seis} *0.88

Note: Shear Data includes annular gap reduction factor of 0.5

For optimised performance data, please use Ramset iExpert Anchoring Software.

DESCRIPTION AND PART NUMBERS

Description	Cartridge Size	Part No.
ChemSet Reo502 PLUS	600ml	RE0502P600

ENGINEERING PROPERTIES Reo 502™ Plus ChemSet™ Anchor Studs and Threaded Rod

Anchor Size, d _b	Grade 8.8 Threaded Rod				Stainless Steel High Corrosion Resistance HCR Grade 1.4529/1.4565 Threaded Rod				Section modulus Z (mm ³)
	Shank diameter, d _s (mm)	Stressed Area (mm ²)	Yield Strength f _y (MPa)	UTS f _u (MPa)	Shank diameter, d _s (mm)	Stressed Area (mm ²)	Yield Strength f _y (MPa)	UTS f _u (MPa)	
M10	8.6	58	640	800	8.2	52.8	450	650	62.3
M12	10.4	84.3	640	800	10	78.5	450	650	109.2
M16	14.1	157	640	800	14	153.9	450	650	277.5
M20	17.7	245	640	800	17.2	232.4	450	650	540.9
M24	21.2	353	640	800	20.7	336.5	450	650	935.5
M30	26.7	561	640	800	-	-	-	-	-

Refer to "Engineering Properties" for ChemSet™ Anchor Studs Grade 5.8 and AISI 316 Stainless Steel in the SARB ANZ on page 141.

ChemSet™ Reo 502™ PLUS

STRENGTH LIMIT STATE DESIGN

AVAILABLE IN AUSTRALIA ONLY

Seismic Anchors - ChemSet™ Reo 502™ PLUS - Anchor Studs

STEP 1

Select anchor to be evaluated

Table 1a Indicative combined loading - interaction diagram

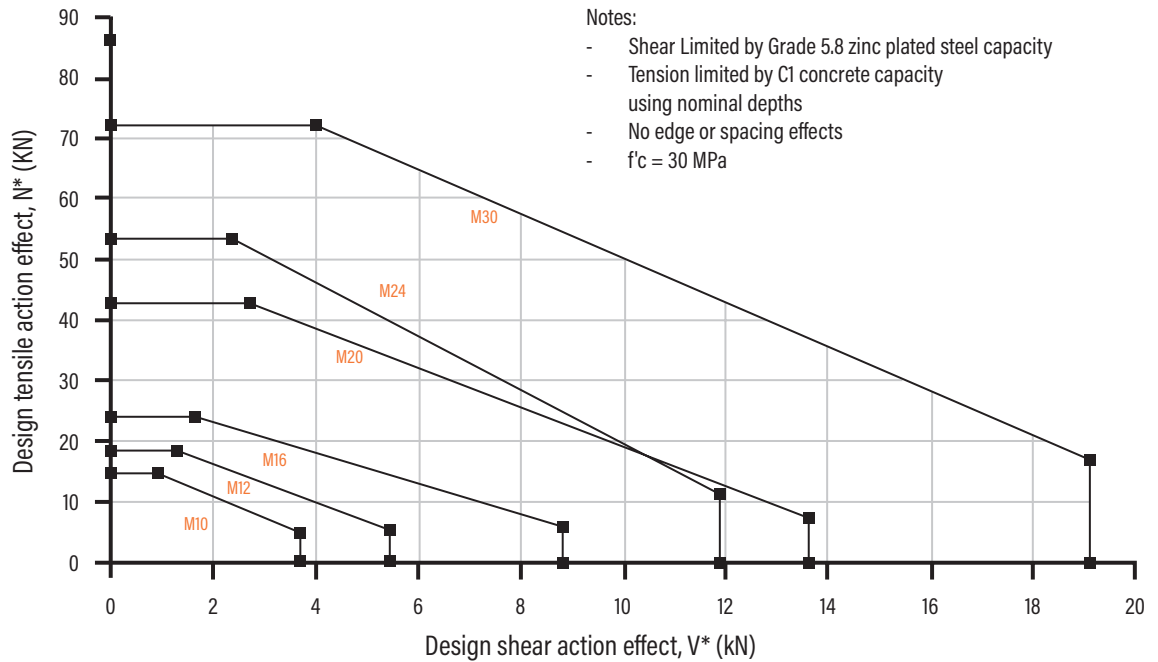

Table 1b Absolute minimum edge distance and anchor spacing values, e_m and a_m (mm)

Anchor size, d _s M10	M10	M12	M16	M20	M24	M30
Min. Anchor Spacing - a _m	40	40	40	50	50	60
Min. Edge Distance - e _m	40	40	40	50	50	60

Step 1c Calculate anchor effective depth, h (mm)

Refer to "Description and Part Numbers" table for ChemSet™ Anchor Studs page in the SARB ANZ on page 141.

Effective depth, h (mm)

Preferred $h = h_n$ otherwise,

$h = L_e - t$

t = total thickness of material(s) being fastened.

Substrate thickness b _m (mm)		
Anchor Stud Size (mm)		
M10	M12	M16 to M24
h + 30mm ≥ 100mm		h + (2 x d _n)

Checkpoint 1

Anchor size determined, absolute minima compliance achieved, effective depth (h) calculated.

ChemSet™ Reo 502™ PLUS

STRENGTH LIMIT STATE DESIGN

AVAILABLE IN AUSTRALIA ONLY

Seismic Anchors - ChemSet™ Reo 502™ PLUS - Anchor Studs

STEP 2 Verify Seismic C1 cracked concrete tensile capacity - per anchor

Table 2a - Seismic (C1) Cracked concrete combined Pull-out and concrete cone resistance, tension

$$N_{Rd,p,seis}^0 = \alpha_{seis} N_{Rk,p,seis}^0 / \gamma_{MSP} \text{ (kN)} \quad \gamma_{MSP} = 1.5, \alpha_{N,seis} = 0.85$$

$$f_c = 30 \text{ MPa where } N_{Rk,p,seis}^0 = \pi * d_b * h * \tau_{Rk,cr,seis}$$

Anchor Size, d_b	C1 Seismic Data					
	M10	M12	M16	M20	M24	M30
Drilled Hole Dia, d_h (mm)	12	14	18	22	26	35
Effective Depth, h (mm)						
70	11.0					
80	12.6					
90	14.2	15.2				
100	15.7	16.9				
110	17.3	18.6	21.5			
120	18.9	20.3	23.5			
125	19.7	21.1	24.4			
140	22.0	23.6	27.4			
150	23.6	25.3	29.3	37.0		
160	25.2	27.0	31.3	39.5		
170	26.8	28.7	33.2	41.9	43.6	
180	28.3	30.4	35.2	44.4	46.2	
190	29.9	32.1	37.1	46.9	48.8	
200	31.5	33.8	39.1	49.3	51.3	
210		35.5	41.1	51.8	53.9	54.3
240		40.5	46.9	59.2	61.6	62.1
280			54.7	69.1	71.9	72.4
320			62.6	78.9	82.1	82.7
350				86.3	89.8	90.5
400				98.6	102.6	103.4
450					115.5	116.3
480					123.2	124.1
550						142.2
600						155.1

Bold values are at ChemSet Anchors Stud nominal depths

All data relevant for Dry, Wet and Flooded Holes

For single anchor values: Multiply $N_{Rd,p,seis}^0 * 1.17$

For optimised performance data, please use Ramset iExpert Anchoring Software.

Table 2b-1 Seismic Cracked concrete service temperature limits effect, tension, X_{ns}

Anchor size, d_b	Service temperature limits effect, tension,					
	M10	M12	M16	M20	M24	M30
Service temperature (°C)						
-40 °C to +70 °C				1.00		

Table 2b-2 Seismic Cracked concrete compressive strength effect, tension, X_{nc}

f_c (MPa)	20	25	30	40	50
X_{nc}	0.96	0.98	1.00	1.029	1.048

ChemSet™ Reo 502™ PLUS

STRENGTH LIMIT STATE DESIGN

AVAILABLE IN AUSTRALIA ONLY

Seismic Anchors - ChemSet™ Reo 502™ PLUS - Anchor Studs

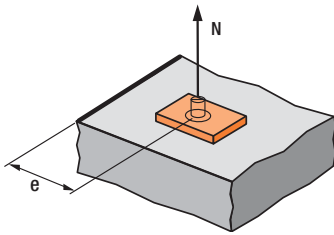

$$X_{ne} = 0.25 + 0.5 \cdot (e/h)$$

Where $e_m \leq e \leq e_c$

$$e_c = 1.5 \cdot h$$

Note: Tabled values are based on the nominal effective depth, h shown in the installation details. For other values of X_{ne} , please use equation shown above.

Table 2c - Seismic cracked concrete Edge distance effect, tension, X_{ne}

Anchor size, db	M10	M12	M16	M20	M24	M30
Edge distance, e (mm)						
40	0.47	0.43	0.41			
45	0.50	0.45	0.43			
50	0.53	0.48	0.45	0.40	0.37	
55	0.56	0.50	0.47	0.41	0.38	
60	0.58	0.52	0.49	0.43	0.39	0.36
65	0.61	0.55	0.51	0.44	0.40	0.37
70	0.64	0.57	0.53	0.46	0.42	0.38
80	0.69	0.61	0.57	0.49	0.44	0.39
100	0.81	0.70	0.65	0.54	0.49	0.43
115	0.89	0.77	0.71	0.59	0.52	0.46
135	1.00	0.86	0.79	0.65	0.57	0.49
165		1.00	0.91	0.74	0.64	0.54
187			1.00	0.80	0.70	0.58
255				1.00	0.86	0.71
315					1.00	0.81
420						1.00

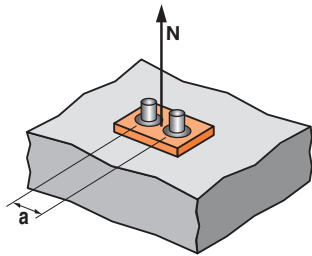

$$X_{na} = 0.5 + a/(6 \cdot h)$$

Where $a_m \leq a \leq a_c$

$$a_c = 3 \cdot h$$

Note: Tabled values are based on the nominal effective depth, h shown in the installation details. For other values X_{na} , please use equation shown above.

Table 2d - Seismic cracked concrete anchor spacing effect, tension, X_{na}

Anchor size, d _b	M10	M12	M16	M20	M24	M30
Anchor spacing, a (mm)						
40	0.57	0.56	0.55			
45	0.58	0.57	0.56			
50	0.59	0.58	0.57	0.55	0.54	
55	0.60	0.58	0.57	0.55	0.54	
60	0.61	0.59	0.58	0.56	0.55	0.54
65	0.62	0.60	0.59	0.56	0.55	0.54
85	0.66	0.63	0.61	0.58	0.57	0.55
100	0.69	0.65	0.63	0.60	0.58	0.56
125	0.73	0.69	0.67	0.62	0.60	0.57
150	0.78	0.73	0.70	0.65	0.62	0.59
200	0.87	0.80	0.77	0.70	0.66	0.62
270	1.00	0.91	0.86	0.76	0.71	0.66
330		1.00	0.94	0.82	0.76	0.70
375			1.00	0.87	0.80	0.72
510				1.00	0.90	0.80
630					1.00	0.88
840						1.00

Checkpoint

2

Design seismic cracked concrete combined pull-out and concrete cone resistance, $N_{Rd,p,seis}$

$$N_{Rd,p,seis} = N_{Rd,p,seis}^0 \cdot X_{ns} \cdot X_{nc} \cdot X_{ne} \cdot X_{na}$$

STEP

3

Verify seismic C1 cracked concrete tensile resistance - per anchor

Table 3a - Seismic C1 Cracked Concrete steel resistance, tensile, $N_{Rd,s,seis} = \alpha_{seis} N_{Rk,s,seis} / \gamma_{Ms}$ (kN), $\alpha_{seis} = 1.0$

$\gamma_{Ms} = 1.5$ for Grade 5.8 and Grade 8.8 Carbon Steel

$\gamma_{Ms} = 1.87$ for A4 316 Stainless Steel

$\gamma_{Ms} = 1.5$ for HCR 1.4529 Stainless Steel

Anchor size, d _b	M10	M12	M16	M20	M24	M30
Grade 5.8 Carbon Steel	19.3	28.0	52.7	82.0	118.0	187.3
Grade 8.8 Carbon Steel	30.7	44.7	84.0	130.7	188.0	299.3
A4 316 Stainless Steel	21.9	31.6	58.8	92.0	132.1	210.2
HCR 1.4529 Stainless Steel	27.3	39.3	73.3	114.7	164.7	262.2

Checkpoint

3

Design seismic C1 cracked concrete tensile resistance, $N_{Rd,seis}$

$$N_{Rd,seis} = \text{minimum of } N_{Rd,p,seis}, N_{Rd,s,seis}$$

Check $N^*/N_{Rd,seis} \leq 1$,
if not satisfied return to step 1

ChemSet™ Reo 502™ PLUS

STRENGTH LIMIT STATE DESIGN

AVAILABLE IN AUSTRALIA ONLY

Seismic Anchors - ChemSet™ Reo 502™ PLUS - Anchor Studs

STEP 4

Step 4 - Verify seismic C1 cracked concrete edge shear resistance - per anchor

Table 4a - Seismic (C1) cracked concrete edge resistance, $V_{Rd,c,seis}^0 = \alpha_{seis} V_{Rk,c,seis}^0 / \gamma_{Mc}$ (kN), $\gamma_{Mc} = 1.5$, $\alpha_{seis} = 0.85$, $f'_c = 30$ MPa

Anchor size, d_b	M10	M12	M16	M20	M24	M30
Effective depth, h (mm)	90	110	125	170	210	280
Edge distance, e_m						
40	1.3	1.5	1.6			
50				2.5	2.8	
60						4.2

Note: Data includes annular gap reduction factor of 0.5.

For single anchor values: Multiply $V_{Rd,c,seis}^0$ * 1.17

For optimised performance data, please use Ramset iExpert Anchoring Software.

Table 4b - Seismic cracked concrete compressive strength effect, shear, X_{vc}

f'_c (MPa)	20	25	30	40	50
X_{vc}	0.82	0.91	1.00	1.15	1.29

Table 4c - Seismic cracked concrete load direction effect, concrete edge shear, X_{vd}

Angle, α°	0-55	60	70	80	90-180
X_{vd}	1	1.1	1.2	1.5	2

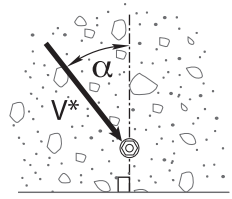

Load direction effect, conc. edge shear, X_{vd}

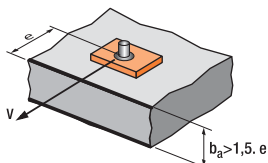

$$X_{ve} = e/e_m * \sqrt{e/e_m}$$

Table 4d - Seismic cracked concrete anchor spacing and edge distance effect, concrete edge shear, X_{ve}

For single anchor fastening X_{ve}

e/e_m	1.0	1.2	1.4	1.6	1.8	2.0	2.2	2.4	2.6	2.8	3.0	3.2
X_{ve}	1.00	1.31	1.66	2.02	2.41	2.83	3.26	3.72	4.19	4.69	5.20	5.72

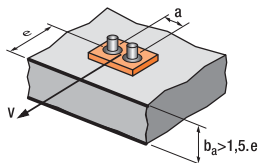

$$X_{ve} = \frac{3 * e + a}{6 * e_m} * \sqrt{e/e_m}$$

For 2 anchors fastening X_{ve}

e/e_m	1.0	1.2	1.4	1.6	1.8	2.0	2.2	2.4	2.6	2.8	3.0	3.2
a/e_m												
1.0	0.67	0.84	1.03	1.22	1.43	1.65	1.88	2.12	2.36	2.62	2.89	3.16
1.5	0.75	0.93	1.12	1.33	1.54	1.77	2.00	2.25	2.50	2.76	3.03	3.31
2.0	0.83	1.02	1.22	1.43	1.65	1.89	2.12	2.38	2.63	2.90	3.18	3.46
2.5	0.92	1.11	1.32	1.54	1.77	2.00	2.25	2.50	2.77	3.04	3.32	3.61
3.0	1.00	1.20	1.42	1.64	1.88	2.12	2.37	2.63	2.90	3.18	3.46	3.76
3.5		1.30	1.52	1.75	1.99	2.24	2.50	2.76	3.04	3.32	3.61	3.91
4.0			1.62	1.86	2.10	2.36	2.62	2.89	3.17	3.46	3.75	4.05
4.5				1.96	2.21	2.47	2.74	3.02	3.31	3.60	3.90	4.20
5.0					2.33	2.59	2.87	3.15	3.44	3.74	4.04	4.35
5.5						2.71	2.99	3.28	3.71	4.02	4.33	4.65
6.0							2.83	3.11	3.41	3.71	4.02	4.33

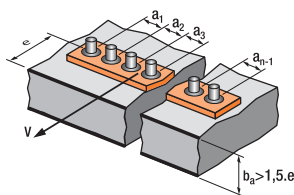

For 3 anchors fastening and more

$$X_{ve} = \frac{3 * e + a_1 + a_2 + a_3 + \dots + a_{n-1}}{3 * n * e_m} * \sqrt{e/e_m}$$

ChemSet™ Reo 502™ PLUS

STRENGTH LIMIT STATE DESIGN

AVAILABLE IN AUSTRALIA ONLY

Seismic Anchors - ChemSet™ Reo 502™ PLUS - Anchor Studs

Table 4e - Seismic (C1) Cracked concrete Pryout failure, $V_{Rd,cp,seis}^0 = \alpha_{seis} V_{Rk,cp} / \gamma_{Mpr}$ (kN), $\gamma_{Mpr} = 1.5$,

$\alpha_{seis} = 0.75, f'_c = 30$ Mpa

Anchor size, d_b	M10	M12	M16	M20	M24	M30
Effective depth, h (mm)	90	110	125	170	210	280
C1 Seismic Data	12.5	16.4	21.6	37.0	47.5	63.9

Note: Data includes annular gap reduction factor of 0.5

For single anchor values: Multiply $V_{Rd,cp,seis}^0$ *1.13

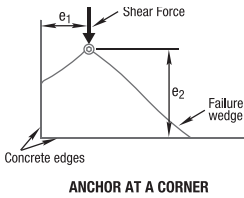

Table 4f Anchor at a corner effect, concrete edge shear, X_{Vs}

Note: For $e_1/e_2 > 1.25, X_{Vs} = 1.0$

Edge distance, e_2 (mm)	25	30	35	50	60	75	125	200	300	400	600	900
Edge distance, e_1 (mm)												
25	0.86	0.77	0.70	0.58	0.53	0.49	0.41	0.37	0.35	0.34	0.32	0.32
30	0.97	0.86	0.78	0.64	0.58	0.52	0.43	0.38	0.36	0.34	0.33	0.32
35	1.00	0.95	0.86	0.69	0.63	0.56	0.46	0.40	0.37	0.35	0.33	0.32
50	1.00	1.00	1.00	0.86	0.77	0.67	0.52	0.44	0.39	0.37	0.35	0.33
60	1.00	1.00	1.00	0.97	0.86	0.75	0.57	0.47	0.41	0.38	0.36	0.34
75	1.00	1.00	1.00	1.00	1.00	0.86	0.64	0.51	0.44	0.41	0.37	0.35
125	1.00	1.00	1.00	1.00	1.00	1.00	0.86	0.65	0.53	0.48	0.42	0.38
200	1.00	1.00	1.00	1.00	1.00	1.00	1.00	0.86	0.67	0.58	0.49	0.42
300	1.00	1.00	1.00	1.00	1.00	1.00	1.00	1.00	0.86	0.72	0.58	0.49
400	1.00	1.00	1.00	1.00	1.00	1.00	1.00	1.00	1.00	0.86	0.67	0.55
500	1.00	1.00	1.00	1.00	1.00	1.00	1.00	1.00	1.00	1.00	0.77	0.61
600	1.00	1.00	1.00	1.00	1.00	1.00	1.00	1.00	1.00	1.00	0.86	0.67
900	1.00	1.00	1.00	1.00	1.00	1.00	1.00	1.00	1.00	1.00	1.00	0.86

Checkpoint 4a

Design seismic cracked concrete edge shear resistance, $V_{Rd,c,seis}$
 $= V_{Rd,c,seis}^0 * X_{vc} * X_{vd} * X_{ve} * X_{vs}$

Checkpoint 4b

Design seismic cracked concrete Pryout failure,
 $V_{Rd,cp,seis} = V_{Rd,cp,seis}^0 * X_{nc} * X_{ne} * X_{na}$

STEP 5

Verify seismic C1 cracked concrete shear resistance - per anchor

Table 5a - Seismic (C1) Cracked Concrete steel shear resistance, $V_{Rd,s,seis} = \alpha_{seis} V_{Rk,s,seis} / \gamma_{Ms}$ (kN), $\alpha_{seis} = 0.85$

$\gamma_{Ms} = 1.25$ for Grade 5.8 and Grade 8.8 Carbon Steel

$\gamma_{Ms} = 1.56$ for A4 316 Stainless Steel

$\gamma_{Ms} = 1.25$ for HCR 1.4529 Stainless Steel

Anchor size, d_b		C1 Seismic Data					
		M10	M12	M16	M20	M24	M30
Grade 5.8	Zinc Plated Steel	3.7	5.4	8.8	13.6	11.9	19.0
	Hot Dip Galv. Steel	1.8	2.6	4.8	7.3	10.5	16.8
Grade 8.8	Zinc Plated Steel	5.8	8.5	13.9	21.8	19.0	30.6
	Hot Dip Galv. Steel	2.7	4.0	7.5	11.8	16.8	26.9
A4 316	Stainless Steel	4.1	6.0	9.8	15.3	13.3	21.5
HCR 1.4529	Stainless Steel	5.1	7.5	12.2	19.0	16.7	26.9

Note: Data includes annular gap reduction factor of 0.5

For single anchor values: Multiply $V_{Rd,s,seis}$ *1.17

Checkpoint 5

Design seismic C1 cracked concrete shear resistance, $V_{Rd,seis}$
 $V_{Rd,seis} = \text{minimum of } V_{Rd,c,seis}, V_{Rd,cp,seis}, V_{Rd,s,seis}$
 Check $V^*/V_{Rd,seis} \leq 1$,
 if not satisfied return to step 1

ChemSet™ Reo 502™ PLUS

STRENGTH LIMIT STATE DESIGN

AVAILABLE IN AUSTRALIA ONLY

Seismic Anchors - ChemSet™ Reo 502™ PLUS - Anchor Studs

STEP 6 Combined Loading

Checkpoint 6

Check

$$N^*/N_{Rd,seis} + V^*/V_{Rd,seis} \leq 1.0,$$
 if not satisfied return to step 1

Specify - Threaded Stud Anchors
 Ramset™ ChemSet™ Reo 502™ PLUS with
 (Anchor Size) grade 5.8 ChemSet™ Anchor
 Stud (Anchor Stud Part Number) Drilled
 Hole Depth to be (h) mm.

Example
 Ramset™ ChemSet™ Reo 502™ PLUS Injection
 with M16 grade 5.8 ChemSet™ Anchor
 Stud (CS16190GH). Drilled hole depth to
 be 125mm. To be installed according to
 Ramset™ Installation Instructions.

Use Ramset™ iExpert Anchor Software for optimised calculation or where a greater range of anchor layout detail is needed.

ChemSet™ Reo 502™ PLUS

SEISMIC REINFORCING BAR - CHEMICAL INJECTION

Back to index

AVAILABLE IN AUSTRALIA ONLY

(New Zealand refer to EPCON™ C6 PLUS range)

GENERAL INFORMATION

Performance Related



Installation Related



Product

ChemSet™ Reo 502™ PLUS is a heavy duty pure Epoxy for anchoring threaded studs and reinforcing bar into cracked and uncracked concrete.

Compliance

European Technical Assessment (option 1) - ETA-18/0675

Design according to:

- AS5216 (formerly TS101)
- AS1170.4 - Earthquake Actions
- EN1992-4 (formerly ETAG001 Annex C, E & TR045)
- Use enclosed data for simplified calculation method

Use Ramset™ iExpert Anchor Software for optimised calculation or where a greater range of anchor layout detail is needed.

Benefits, Advantages and Features

- 100 year working life

Greater productivity:

- Anchors in dry, damp, wet or flooded holes
- Easy dispensing even in cold weather

Greater security:

- Strong bond
- Rated for sustained loading

Versatile:

- Anchors in carbide drilled and diamond drilled holes*
- Cold and temperate climates

Greater safety:

- Low odour
- VOC Compliant



Principal Applications

- Threaded Studs
- Starter Bars
- Threaded Inserts
- Over-head installation
- Steel Columns
- Hand Rails
- Road Stitching

Recommended Installation Temperatures

	Minimum	Maximum
Substrate	5°C	40°C
Adhesive	10°C	40°C

Service Temperature Limits

-40°C to 70°C

Setting Times

Temperature of base material	Cartridge Temperature	Gel Time	Curing time in dry and wet concrete
5°C	Minimum 10°C	300 min	24 h
10°C	10°C	150 min	18 h
15°C	15°C	40 min	12 h
20°C	20°C	25 min	8 h
25°C	25°C	18 min	6 h
30°C	30°C	12 min	4 h
40°C	40°C	6 min	2 h

Note: Cartridge temperature minimum +10°C

Note

*Performance of cored & oversized holes was not included in the ETAG test program and therefore is based on testing conducted at Ramset™ Product Engineering Laboratory.

Installation

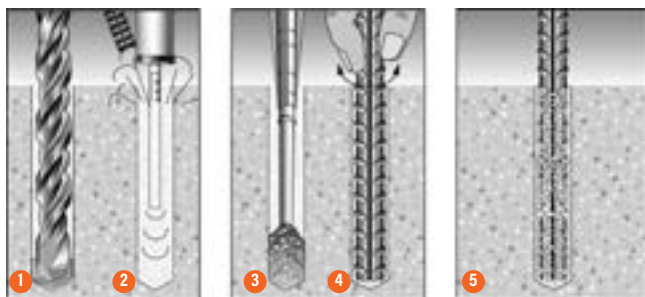

1. Drill recommended diameter and depth hole.
2. **Important:** Use Ramset™ Dustless Drilling System to ensure holes are clean. Alternatively, clean dust and debris from hole with stiff wire or nylon brush and blower in the following sequence: blow x 2, brush x 2, blow x 2, brush x 2, blow x 2.
3. Dispense adhesive to waste until colour is uniform light grey (2-3 trigger pulls). Insert mixing nozzle to bottom of hole. Fill hole to 3/4 the hole depth slowly, ensuring no air pockets form.
4. Insert Ramset™ ChemSet™ Anchor Stud/rebar to bottom of hole while turning.
5. Allow ChemSet™ Reo 502™ PLUS to cure as per setting times.

Seismic Anchors - ChemSet™ Reo 502™ PLUS - Reinforcing Bar

ChemSet™ Reo 502™ PLUS

SEISMIC REINFORCING BAR - CHEMICAL INJECTION

AVAILABLE IN AUSTRALIA ONLY

Installation and performance details: ChemSet™ Reo 502™ PLUS and ChemSet™ Reinforcing Bar

Rebar size, d _b (mm)	Drilled hole diameter, d _h (mm)	Anchor effective depth, h (mm)	Optimum dimensions*		Concrete substrate thickness, b _m (mm)	Gr 500 Rebar - Steel		Seismic (C1) Cracked Concrete reduced characteristic tensile capacity, N ⁰ _{Rd,p,seis} (kN) **		
			Anchor* spacing, a _c (mm)	Edge* distance, e _c (mm)		Tension, φN _{us} (kN)***	Shear, φV _{us} (kN)	Concrete Compressive Strength, f _c		
								20 MPa	30 Mpa	40 Mpa
10	14	90	270	135	120	30.7	10.7	13.6	14.2	14.6
12	16	110	330	165	140	44.3	15.3	17.9	18.6	19.1
16	20	125	375	187.5	165	79.3	27.3	23.5	24.4	25.1
20	25	170	510	255	220	123.6	46.0	40.3	41.9	43.1
24	32	210	630	315	274	177.7	41.2	51.8	53.9	55.4
32	40	300	900	450	380	315.7	74.0	74.6	77.6	79.8

* For anchor spacings or edge distances less than the minimum, please refer to the simplified strength limit state design process to verify capacity.

** Seismic Cracked concrete combined pull-out and concrete cone resistance, tension = N⁰_{Rd,p,seis} = α_{Nseis} N⁰_{Rk,p,seis} / γ_{Msp} where γ_{Msp} = 1.5

*** Seismic Cracked concrete steel resistance, tension = N_{Rd,s,seis} = α_{Nseis} N⁰_{Rk,s,seis} / γ_{Ms} (kN) where γ_{Ms} = 1.4

For optimised performance data, please use Ramset iExpert Anchoring Software.

DESCRIPTION AND PART NUMBERS

Description	Cartridge Size	Part No.
ChemSet Reo502 PLUS	600ml	RE0502P600

Drilled hole depth, h ₁ (mm) h ₁ = h h = Effective depth
--

Substrate thickness b _m (mm)					
Anchor Stud Size (mm)					
10	12	16	20	24	32
h + 30mm ≥ 100mm			h + (2 x d _h)		

Typical Engineering Properties of Grade 500 Reinforcing Bar

Rebar Size	10	12	16	20	24	32
Drilled Hole Dia, d _h (mm)	12	15	20	25	32	40
Stress Area, A _s (mm ²)	78.5	113	201	314	491	804
Yield Stress, f _{sy} (MPa)	500	500	500	500	500	500
Tensile Steel Yield Capacity, N _{sy} (kN)	39.3	56.5	100.5	157.0	226.0	402.0

For further information refer to reinforcing bar manufacturer's published information and current revision of AS/NZS 4671

Seismic Anchors - ChemSet™ Reo 502™ PLUS - Reinforcing Bar

ChemSet™ Reo 502™ PLUS

SEISMIC REINFORCING BAR - CHEMICAL INJECTION

AVAILABLE IN AUSTRALIA ONLY

Seismic Anchors - ChemSet™ Reo 502™ PLUS - Reinforcing Bar

STEP 1

Select anchor to be evaluated

Table 1a Indicative combined loading - interaction diagram

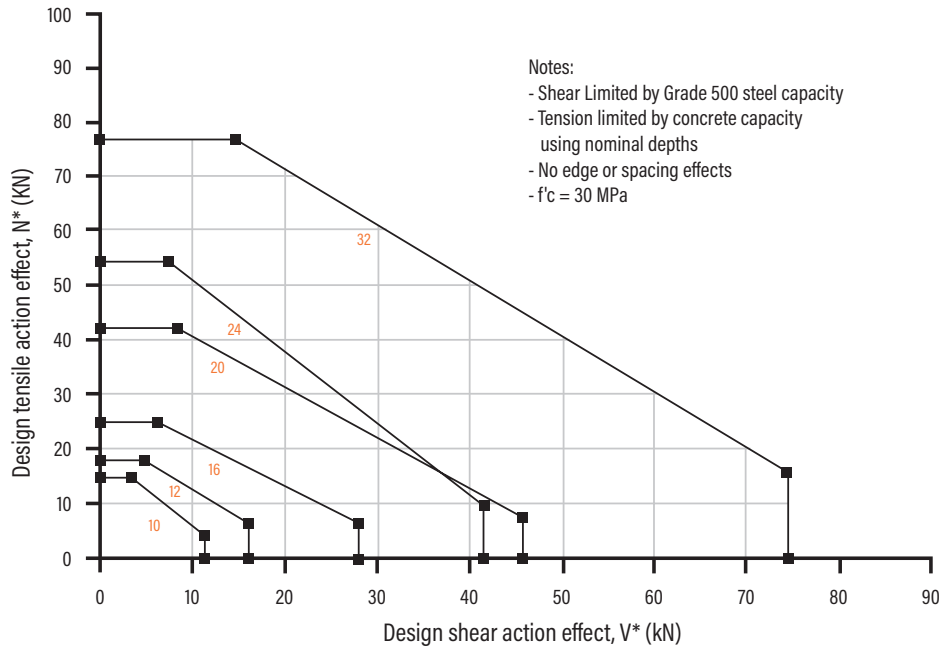

Table 1b Absolute minimum edge distance and anchor spacing values, e_m and a_m (mm)

Anchor size, d _s M10	10	12	16	20	24	32
Min. Anchor Spacing - a _m	40	40	40	50	50	70
Min. Edge Distance - e _m	40	40	40	50	50	70

Step 1c Calculate anchor effective depth, h (mm)

Refer to nominal recommended effective depths, h listed in installation and performance details in the SARB ANZ on the previous page.

Substrate thickness b _m (mm)					
Anchor Stud Size (mm)					
10	12	16	20	24	32
h + 30mm ≥ 100mm			h + (2 x d _s)		

Checkpoint 1

Anchor size determined, absolute minima compliance achieved, effective depth (h) calculated.

ChemSet™ Reo 502™ PLUS

STRENGTH LIMIT STATE DESIGN

AVAILABLE IN AUSTRALIA ONLY

Seismic Anchors - ChemSet™ Reo 502™ PLUS - Reinforcing Bar

STEP 2 Verify Seismic C1 cracked concrete tensile capacity - per anchor

Table 2a - Seismic (C1) Cracked concrete combined Pull-out and concrete cone resistance, tension

$$N_{Rd,p,seis}^0 = \alpha_{seis} N_{Rk,p,seis}^0 / \gamma_{Msp} \text{ (kN)}, \gamma_{Msp} = 1.5, \alpha_{N,seis} = 0.85, f'c = 30 \text{ MPa, where } N_{Rk,p,seis}^0 = \pi * d_b * h * \tau_{Rk,cr,seis}$$

Anchor Size, db	10	12	16	20	24	32
Drilled Hole Dia, dh (mm)	14	16	20	25	32	40
Effective Depth, h (mm)						
70	11.0					
80	12.6					
90	14.2	15.2				
100	15.8	16.9				
110	17.3	18.6	21.5			
120	18.9	20.3	23.5			
125	19.7	21.1	24.4			
140	22.1	23.6	27.4			
150	23.6	25.3	29.3	37.0		
160	25.2	27.0	31.3	39.5		
170	26.8	28.7	33.2	41.9	43.6	
180	28.4	30.4	35.2	44.4	46.2	
190	29.9	32.1	37.1	46.9	48.8	
200	31.5	33.8	39.1	49.3	51.3	
210		35.5	41.0	51.8	53.9	54.3
240		40.5	46.9	59.2	61.6	62.1
300			58.6	74.0	77.0	77.6
320			62.5	78.9	82.1	82.7
350				86.3	89.8	90.5
400				98.7	102.6	103.4
450					115.5	116.3
480					123.2	124.1
550						142.2
600						155.1

Bold values are at ChemSet Rebar Anchor nominal depths

Flooded Holes: Multiply $N_{Rd,p,seis}^0 * 0.83$

For single anchor values: Multiply $N_{Rd,p,seis}^0 * 1.17$

For optimised performance data, please use Ramset iExpert Anchoring Software.

Table 2b-1 Seismic Cracked concrete service temperature limits effect, tension, X_{ns}

Anchor size, db	Service temperature limits effect, tension, X_{ns}					
	10	12	16	20	24	32
Service temperature (°C)						
-40 °C to +70 °C	1.00					

Table 2b-2 Seismic Cracked concrete compressive strength effect, tension, X_{nc}

f'c (MPa)	20	25	30	40	50
X_{nc}	0.96	0.98	1.00	1.029	1.048

ChemSet™ Reo 502™ PLUS

STRENGTH LIMIT STATE DESIGN

AVAILABLE IN AUSTRALIA ONLY

Seismic Anchors - ChemSet™ Reo 502™ PLUS - Reinforcing Bar

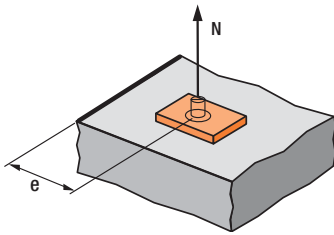

$$X_{ne} = 0.25 + 0.5 \cdot (e/h)$$

Where $e_m \leq e \leq e_c$

$$e_c = 1.5 \cdot h$$

Note: Tabled values are based on the nominal effective depth, h shown in the installation details. For other values of X_{ne} , please use equation shown above.

Table 2c - Seismic cracked concrete Edge distance effect, tension, X_{ne}

Anchor size, d_b	10	12	16	20	24	32
Edge distance, e (mm)						
40	0.47	0.43	0.41			
45	0.50	0.45	0.43			
50	0.53	0.48	0.45	0.40	0.37	
55	0.56	0.50	0.47	0.41	0.38	
60	0.58	0.52	0.49	0.43	0.39	
65	0.61	0.55	0.51	0.44	0.40	
70	0.64	0.57	0.53	0.46	0.42	0.37
80	0.69	0.61	0.57	0.49	0.44	0.38
100	0.81	0.70	0.65	0.54	0.49	0.42
115	0.89	0.77	0.71	0.59	0.52	0.44
135	1	0.86	0.79	0.65	0.57	0.48
165		1	0.91	0.74	0.64	0.53
187			1	0.80	0.70	0.56
255				1	0.86	0.68
315					1	0.78
420						1

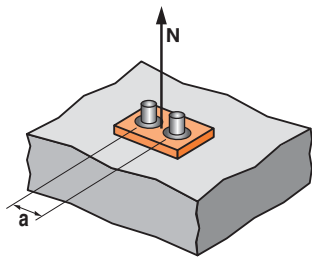

$$X_{na} = 0.5 + a/(6 \cdot h)$$

Where $a_m \leq a \leq a_c$

$$a_c = 3 \cdot h$$

Note: Tabled values are based on the nominal effective depth, h shown in the installation details. For other values X_{na} , please use equation shown above.

Table 2d - Seismic cracked concrete anchor spacing effect, tension, X_{na}

Anchor size, d_b	10	12	16	20	24	32
Anchor spacing, a (mm)						
40	0.57	0.56	0.55			
45	0.58	0.57	0.56			
50	0.59	0.58	0.57	0.55	0.54	
55	0.60	0.58	0.57	0.55	0.54	
60	0.61	0.59	0.58	0.56	0.55	
65	0.62	0.60	0.59	0.56	0.55	
70	0.63	0.61	0.59	0.57	0.56	0.54
100	0.69	0.65	0.63	0.60	0.58	0.56
125	0.73	0.69	0.67	0.62	0.60	0.57
150	0.78	0.73	0.70	0.65	0.62	0.58
200	0.87	0.80	0.77	0.70	0.66	0.61
270	1	0.91	0.86	0.76	0.71	0.65
330		1	0.94	0.82	0.76	0.68
375			1	0.87	0.80	0.71
510				1	0.90	0.78
630					1	0.85
840						1

Checkpoint 2

Design seismic cracked concrete combined pull-out and concrete cone resistance, $N_{Rd,p,seis}$

$$N_{Rd,p,seis} = N_{Rd,p,seis}^0 \cdot X_{ns} \cdot X_{nc} \cdot X_{ne} \cdot X_{na}$$

STEP 3

Verify seismic C1 cracked concrete tensile resistance - per anchor

Table 3a - Seismic C1 Cracked Concrete steel resistance, tensile, $N_{Rd,s,seis} = \alpha_{seis} N_{Rk,s,seis} / \gamma_{Ms}$ (kN) where $\alpha_{seis} = 1.0$, $\gamma_{Ms} = 1.4$ for Grade 500 Rebar

Anchor size, d_b	10	12	16	20	24	30
Rebar Gr 500	30.7	44.3	79.3	123.6	177.7	315.7

Checkpoint 3

Design seismic C1 cracked concrete tensile resistance, $N_{Rd,seis}$

$$N_{Rd,seis} = \text{minimum of } N_{Rd,p,seis}, N_{Rd,s,seis}$$

Check $N^*/N_{Rd,seis} \leq 1$,
if not satisfied return to step 1

ChemSet™ Reo 502™ PLUS

STRENGTH LIMIT STATE DESIGN

AVAILABLE IN AUSTRALIA ONLY

Seismic Anchors - ChemSet™ Reo 502™ PLUS - Reinforcing Bar

STEP 4

Step 4 - Verify seismic C1 cracked concrete edge shear resistance - per anchor

Table 4a - Seismic cracked concrete edge resistance, $V_{Rd,c,seis}^0 = \alpha_{seis} V_{Rk,c,seis}^0 / \gamma_{Mc}$ (kN), $\gamma_{Mc} = 1.5$, $\alpha_{seis} = 0.85$, $f'_c = 30$ MPa

Anchor size, d_b	10	12	16	20	24	32
Effective depth, h (mm)	90	110	125	170	210	300
Edge distance, e_m						
40	2.7	2.9	3.3			
50				5.0	5.7	
70						10.3

For single anchor values: Multiply $V_{Rd,c,seis}^0$ *1.17
For optimised performance data, please use Ramset iExpert Anchoring Software.

Table 4b - Seismic cracked concrete compressive strength effect, shear, X_{vc}

f'_c (MPa)	20	25	30	40	50
X_{vc}	0.82	0.9	1	1.15	1.29

Table 4c - Seismic cracked concrete load direction effect, concrete edge shear, X_{vd}

Angle, α°	0-55	60	70	80	90-180
X_{vd}	1	1.1	1.2	1.5	2

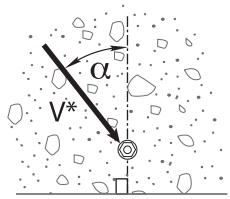

Load direction effect, conc. edge shear, X_{vd}

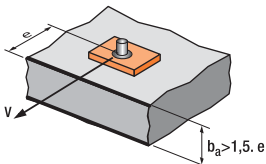

$$X_{ve} = e/e_m * \sqrt{e/e_m}$$

Table 4d - Seismic cracked concrete anchor spacing and edge distance effect, concrete edge shear, X_{ve}

For single anchor fastening X_{ve}

e/e_m	1.0	1.2	1.4	1.6	1.8	2.0	2.2	2.4	2.6	2.8	3.0	3.2
X_{ve}	1.00	1.31	1.66	2.02	2.41	2.83	3.26	3.72	4.19	4.69	5.20	5.72

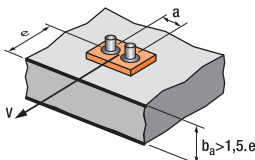

$$X_{ve} = \frac{3 * e + a}{6 * e_m} * \sqrt{e/e_m}$$

For 2 anchors fastening X_{ve}

e/e_m	1.0	1.2	1.4	1.6	1.8	2.0	2.2	2.4	2.6	2.8	3.0	3.2
a/e_m												
1.0	0.67	0.84	1.03	1.22	1.43	1.65	1.88	2.12	2.36	2.62	2.89	3.16
1.5	0.75	0.93	1.12	1.33	1.54	1.77	2.00	2.25	2.50	2.76	3.03	3.31
2.0	0.83	1.02	1.22	1.43	1.65	1.89	2.12	2.38	2.63	2.90	3.18	3.46
2.5	0.92	1.11	1.32	1.54	1.77	2.00	2.25	2.50	2.77	3.04	3.32	3.61
3.0	1.00	1.20	1.42	1.64	1.88	2.12	2.37	2.63	2.90	3.18	3.46	3.76
3.5		1.30	1.52	1.75	1.99	2.24	2.50	2.76	3.04	3.32	3.61	3.91
4.0			1.62	1.86	2.10	2.36	2.62	2.89	3.17	3.46	3.75	4.05
4.5				1.96	2.21	2.47	2.74	3.02	3.31	3.60	3.90	4.20
5.0					2.33	2.59	2.87	3.15	3.44	3.74	4.04	4.35
5.5						2.71	2.99	3.28	3.71	4.02	4.33	4.65
6.0						2.83	3.11	3.41	3.71	4.02	4.33	4.65

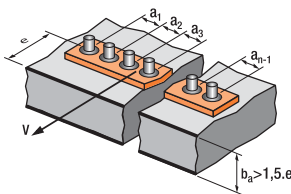

For 3 anchors fastening and more

$$X_{ve} = \frac{3 * e + a_1 + a_2 + a_3 + \dots + a_{n-1}}{3 * n * e_m} * \sqrt{e/e_m}$$

ChemSet™ Reo 502™ PLUS

STRENGTH LIMIT STATE DESIGN

AVAILABLE IN AUSTRALIA ONLY

Seismic Anchors - ChemSet™ Reo 502™ PLUS - Reinforcing Bar

Table 4e - Seismic Cracked concrete Pryout failure, $V_{Rd,cp}^0 = \alpha_{seis} V_{Rk,cp} / \gamma_{Mpr}$ (kN), $\gamma_{Mpr} = 1.5$, $\alpha_{seis} = 0.75$, $f'c = 30$ MPa

Anchor size, d_b	10	12	16	20	24	32
Effective depth, h (mm)	90	110	125	170	210	300
-40°C to +70°C	25.0	32.8	43.1	74.0	95.1	136.9

For single anchor values: Multiply $V_{Rd,cp}^0 * 1.13$

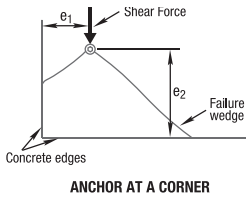

Table 4f Anchor at a corner effect, concrete edge shear, X_{vs}

Note: For $e_1/e_2 > 1.25$, $X_{VS} = 1.0$

Edge distance, e_2 (mm)	25	30	35	50	60	75	125	200	300	400	600	900
Edge distance, e_1 (mm)												
25	0.86	0.77	0.70	0.58	0.53	0.49	0.41	0.37	0.35	0.34	0.32	0.32
30	0.97	0.86	0.78	0.64	0.58	0.52	0.43	0.38	0.36	0.34	0.33	0.32
35	1.00	0.95	0.86	0.69	0.63	0.56	0.46	0.40	0.37	0.35	0.33	0.32
50	1.00	1.00	1.00	0.86	0.77	0.67	0.52	0.44	0.39	0.37	0.35	0.33
60	1.00	1.00	1.00	0.97	0.86	0.75	0.57	0.47	0.41	0.38	0.36	0.34
75	1.00	1.00	1.00	1.00	1.00	0.86	0.64	0.51	0.44	0.41	0.37	0.35
125	1.00	1.00	1.00	1.00	1.00	1.00	0.86	0.65	0.53	0.48	0.42	0.38
200	1.00	1.00	1.00	1.00	1.00	1.00	1.00	0.86	0.67	0.58	0.49	0.42
300	1.00	1.00	1.00	1.00	1.00	1.00	1.00	1.00	0.86	0.72	0.58	0.49
400	1.00	1.00	1.00	1.00	1.00	1.00	1.00	1.00	1.00	0.86	0.67	0.55
500	1.00	1.00	1.00	1.00	1.00	1.00	1.00	1.00	1.00	1.00	0.77	0.61
600	1.00	1.00	1.00	1.00	1.00	1.00	1.00	1.00	1.00	1.00	0.86	0.67
900	1.00	1.00	1.00	1.00	1.00	1.00	1.00	1.00	1.00	1.00	1.00	0.86

Checkpoint 4a

Design seismic cracked concrete edge shear resistance, $V_{Rd,c,seis}$

$$= V_{Rd,c,seis}^0 * X_{vc} * X_{vd} * X_{ve} * X_{vs}$$

Checkpoint 4b

Design seismic cracked concrete Pryout failure,

$$V_{Rd,cp,seis} = V_{Rd,cp,seis}^0 * X_{nc} * X_{ne} * X_{na}$$

STEP 5

Verify seismic C1 cracked concrete shear resistance - per anchor

Table 5a - Seismic (C1) Cracked Concrete steel shear resistance, $V_{Rd,s,seis} = \alpha_{seis} V_{Rk,s,seis} / \gamma_{Ms}$ (kN) where $\alpha_{seis} = 1.0$ and $\gamma_{Ms} = 1.5$

Anchor size, d_b	C1 Seismic Data					
	10	20	16	20	24	32
Rebar Gr 500	10.7	15.3	27.3	46.0	41.2	74.0

Checkpoint 5

Design seismic C1 cracked concrete shear resistance, $V_{Rd,seis}$

$$V_{Rd,seis} = \text{minimum of } V_{Rd,c,seis}, V_{Rd,cp,seis}, V_{Rd,s,seis}$$
 Check $V/V_{Rd,seis} \leq 1$,
 if not satisfied return to step 1

ChemSet™ Reo 502™ Plus

STRENGTH LIMIT STATE DESIGN

AVAILABLE IN AUSTRALIA ONLY

Seismic Anchors - ChemSet™ Reo 502™ PLUS - Reinforcing Bar

STEP 6 Combined Loading

Checkpoint 6

Check

$$N^*/N_{Rd,seis} + V^*/V_{Rd,seis} \leq 1.0,$$
 if not satisfied return to step 1

Specify - Reinforcing Bar Anchorage

Ramset™ ChemSet™ Reo 502™ PLUS with (Anchor Size) grade 500 Rebar.
 Drilled hole depth to be (h) mm.

Example

Ramset™ ChemSet™ Reo 502™ PLUS with 20mm grade 500 Rebar
 Drilled hole depth to be 170 mm.
 To be installed in accordance with Ramset™ Installation Instructions.

Use Ramset™ iExpert Anchor Software for optimised calculation or where a greater range of anchor layout detail is needed.

ChemSet™ 801 Xtrem™ XC²

SEISMIC ANCHOR STUDS - CHEMICAL INJECTION

[Back to index](#)

GENERAL INFORMATION

Performance Related	Material Specification	Installation Related

Product

ChemSet™ 801 Xtrem™ XC² is a heavy duty Vinylester adhesive for anchoring threaded studs and reinforcing bar into cracked and uncracked concrete.



Compliance

European Technical Assessment (option 1) - ETA-18/0045

Design according to:

- AS5216 (formerly TS101)
- AS1170.4 - Earthquake Actions
- EN1992-4 (formerly ETAG001 Annex C, E & TR045)
- NZS3101 (A3) Section 17 - Seismic Design C1
- Use enclosed data for simplified calculation method

Use Ramset™ iExpert Anchor Software for optimised calculation or where a greater range of anchor layout detail is needed.

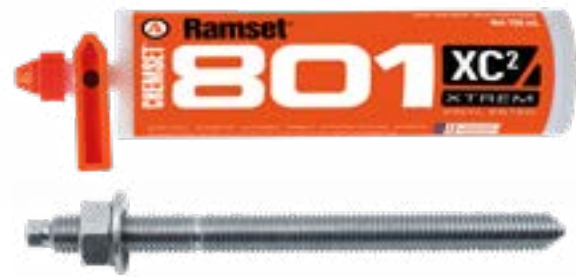

Benefits, Advantages and Features

- 50 year working life

Greater productivity:

- Easy dispensing even in cold weather
- Apply torque in 2 hours @ 20°C

Greater security:

- Strong bond
- Rated for sustained loading

Versatile:

- Earthquake, Fire & Flooded Conditions
- Cold and temperate climates

Greater safety:

- Low odour
- Suitable for contact with drinking water
- VOC Compliant

Made in Australia

Installation

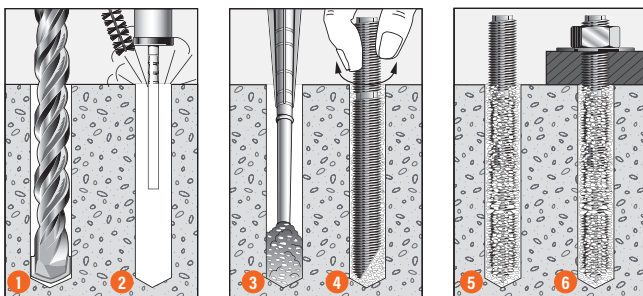

1. Drill recommended diameter and depth hole.
2. **Important:** Use Ramset™ Dustless Drilling System to ensure holes are clean. Alternatively clean dust and debris from hole with stiff wire or nylon brush and blower in the following sequence: blow x 2, brush x 2, blow x 2.
3. Dispense adhesive to waste until colour is uniform light grey (2-3 trigger pulls). Insert mixing nozzle to bottom of hole. Fill hole to 3/4 the hole depth slowly, ensuring no air pockets form.
4. Insert Ramset™ ChemSet™ Anchor Stud/rebar to bottom of hole while turning.
5. Allow Chemset™801 Xtrem™ XC² to cure as per setting times.
6. Attach fixture.

Principal Applications

- Threaded Studs
- Starter Bars
- Threaded Inserts
- Over-head installation
- Steel Columns
- Hand Rails
- Road Stitching

Recommended Installation Temperatures

	Minimum	Maximum
Substrate	5°C	40°C
Adhesive	5°C	40°C

Service Temperature Limits

-40°C to 80°C

Setting Times

Temperature of base material	Cartridge Temperature	Gel Time	Curing time in dry and wet concrete
+5°C	60 min	240 min	480 min
6°C - 10°C	40 min	180 min	360 min
11°C - 20°C	15 min	120 min	240 min
21°C - 30°C	8 min	90 min	180 min
31°C - 40°C	4 min	60 min	120 min

Note: Cartridge temperature minimum +5°C

ChemSet™ 801 Xtrem™ XC²

SEISMIC ANCHOR STUDS - CHEMICAL INJECTION

Installation and performance details: ChemSet 801 Xtrem™ XC² and ChemSet™ Anchor Studs

Anchor size, d _b (mm)	Drilled hole diameter, d _h (mm)	Fixture hole diameter, d _f (mm)	Anchor effective depth, h (mm)	Tightening torque, T _r (Nm)	Optimum dimensions*		Concrete substrate thickness, b _m (mm)
					Anchor* spacing, a _c (mm)	Edge* distance, e _c (mm)	
M10	12	12	90	20	270	135	120
M12	14	14	110	30	330	165	140
M16	18	18	125	60	375	187	160
M20	25	22	170	120	510	255	220
M24	28	26	210	200	630	315	265
M30	35	33	280	400	840	420	350

*Note: For shear loads acting towards an edge or where these optimum dimensions are not achievable, please use the simplified strength limit state design process to verify capacity.

Anchor size, d _b (mm)	Reduced Characteristic Capacity**						
	Grade 5.8 Steel Studs		Grade 8.8 Steel Studs		ANSI 316 Stainless Steel Studs		Seismic Cracked Concrete C1
	Shear, V _{Rd,seis} (kN)	Tension, N _{Rd,seis} (kN)****	Shear, V _{Rd,seis} (kN)	Tension, N _{Rd,seis} (kN)****	Shear, V _{Rd,seis} (kN)	Tension, N _{Rd,seis} (kN)****	Tension, N _{Rd,p,Seis} (kN)***
	Concrete Compressive Strength, f' _c						
							20 MPa to 50 MPa
M10	2.8	18.9	4.6	30.9	2.9	19.8	9.9
M12	4.2	28.1	6.7	45.0	4.4	29.5	15.3
M16	8.0	53.9	12.5	83.7	8.6	57.7	21.7
M20	12.1	81.3	19.4	130.7	13.0	87.1	37.5
M24	17.5	117.8	28.0	188.3	18.8	126.2	58.3
M30	29.2	196.4	44.5	299.2	-	-	89.7

** Tension values are based on service temperature limits -40°C to +40°C only. If service temperature limits is beyond this range please contact Ramset Engineer.

***Note: Seismic Cracked concrete combined pull-out and concrete concc resistance, tension = N⁰_{Rd,p,seis} = α_{Nseis} N⁰_{Rk,p,seis} / γ_{Msp} where γ_{Msp} = 1.5

α_{Nseis} = 0.85

****Note: Seismic Cracked Concrete steel resistance, tension = N_{Rd,s,seis} = α_{Nseis} N⁰_{Rk,s,seis} / γ_{Ms} (kN) where γ_{Ms} = 1.5 (Grade 5.8 & 8.8 steel),

γ_{Ms} = 1.73 (A4 316 SS) and (HCR stainless steel)

For optimised performance data, please use Ramset iExpert Anchoring Software.

DESCRIPTION AND PART NUMBERS

Description	Cartridge Size	Part No.
ChemSet™ 801 Xtrem™ XC ²	750ml	C801X750 (AU & NZ)
ChemSet™ 801 Xtrem™ XC ²	380ml	C801X380 (AU Only)

ENGINEERING PROPERTIES

ChemSet™ Anchor Studs and Threaded Rod

Anchor Size, d _b	Grade 8.8 Threaded Rod				Stainless Steel High Corrosion Resistance HCR Grade 1.4529/1.4565 Threaded Rod				Section modulus Z (mm ³)
	Shank diameter, d _s (mm)	Stressed Area (mm ²)	Yield Strength f _y MPa	UTS f _u MPa	Shank diameter, d _s (mm)	Stressed Area (mm ²)	Yield Strength f _y MPa	UTS f _u MPa	
M10	8.6	58	640	800	8.2	52.8	450	650	62.3
M12	10.4	84.3	640	800	10	78.5	450	650	109.2
M16	14.1	157	640	800	14	153.9	450	650	277.5
M20	17.7	245	640	800	17.2	232.4	450	650	540.9
M24	21.2	353	640	800	20.7	336.5	450	650	935.5
M30	26.7	561	640	800	-	-	-	-	-

Engineering Properties™ for ChemSet™ Anchor Studs Grade 5.8 and AISI 316 Stainless Steel in the SARB ANZ on page 141.

ChemSet™ 801 Xtrem™ XC²

STRENGTH LIMIT STATE DESIGN

STEP 1

Select anchor to be evaluated

Table 1a Indicative combined loading - interaction diagram

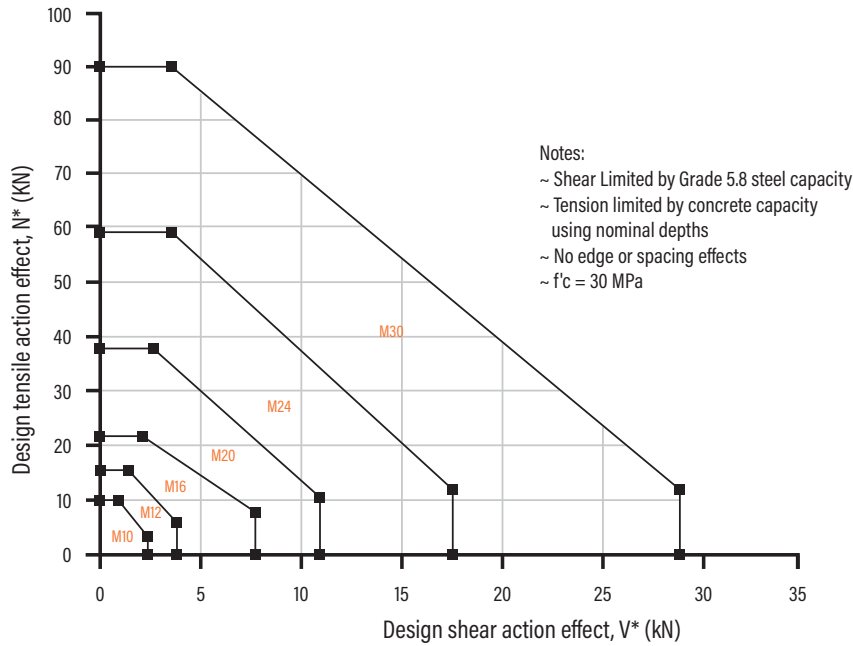

Table 1b Absolute minimum edge distance and anchor spacing values, e_m and a_m (mm)

Anchor size, d _b	M10	M12	M16	M20	M24	M30
Min. Anchor Spacing - a _m	50	60	75	90	115	140
Min. Edge Distance - e _m	45	45	50	55	60	80

Step 1c Calculate anchor effective depth, h (mm)

Refer to "Description and Part Numbers" table for ChemSet Anchor Studs page in the SARB ANZ on page 141.

<p>Effective depth, h (mm)</p> <p>Preferred $h = h_n$ otherwise,</p> <p>$h = L_e - t$</p> <p>t = total thickness of material(s) being fastened.</p>	Substrate thickness b _m (mm)		
	Anchor Stud Size (mm)		
	M10	M12	M16 to M30
	h + 30mm ≥ 100mm		h + (2 x d _h)

Checkpoint 1

Anchor size determined, absolute minima compliance achieved, effective depth (h) calculated.

ChemSet™ 801 Xtrem™ XC²

STRENGTH LIMIT STATE DESIGN

Seismic Anchors - 801 Xtrem™ XC² - Anchor Studs

STEP 2 Verify Seismic C1 cracked concrete tensile capacity - per anchor

Table 2a - Seismic Cracked concrete combined Pull-out and concrete cone resistance, tension

$N_{Rd,p,seis}^0 = \alpha_{seis} N_{Rk,p,seis}^0 / \gamma_{Msp}$ (kN), $\gamma_{Msp} = 1.5$, $\alpha_{N,seis} = 0.85$, $f'c = 30$ MPa
 where $N_{Rk,p,seis}^0 = \pi * d_b * h * \tau_{Rk,cr,seis}$

Anchor Size, d _b	M10	M12	M16	M20	M24	M30
Drilled Hole Dia, d _h (mm)	12	14	18	25	28	35
Effective Depth, h (mm)						
70	7.7					
80	8.8					
90	9.9	12.5				
100	11.0	13.9				
110	12.1	15.3	19.1			
120	13.2	16.7	20.9			
125	13.8	17.4	21.7			
140	15.5	19.4	24.3			
150	16.6	20.8	26.1	33.1		
160	17.7	22.2	27.8	35.3		
170	18.8	23.6	29.5	37.5	47.2	
180	19.9	25.0	31.3	39.7	50.0	
190	21.0	26.4	33.0	41.9	52.8	
200	22.1	27.8	34.8	44.1	55.5	
210		29.2	36.5	46.4	58.3	67.3
240		33.3	41.7	53.0	66.7	76.9
280			48.7	61.8	77.8	89.7
320			55.6	70.6	88.9	102.5
350				77.3	97.2	112.2
400				88.3	111.1	128.2
450					125.0	144.2
480					133.3	153.8
550						176.2
600						192.3

Flooded Holes: Multiply $N_{Rd,p,seis}^0 * 0.75$

For single anchor values: Multiply $N_{Rd,p,seis}^0 * 1.17$

Bold values are at ChemSet Anchors Stud nominal depths

For optimised performance data, please use Ramset iExpert Anchoring Software.

Note: The maximum embedment depth shall be reduced to 12d_b for installation in flooded holes

Table 2b-1 Seismic Cracked concrete service temperature limits effect, tension, X_{ns}

Anchor size, d _b	Service temperature limits effect, tension, X _{ns}					
	M10	M12	M16	M20	M24	M30
Service temperature (°C)						
-40°C to +40°C	1.00	1.00	1.00	1.00	1.00	1.00
-40°C to +80°C	1.00	1.00	1.00	0.92	0.92	0.92

Table 2b-2 Seismic Cracked concrete compressive strength effect, tension, X_{nc}

f'c (MPa)	20	25	30	40	50
X _{nc}	1	1	1	1	1

ChemSet™ 801 Xtrem™ XC²

STRENGTH LIMIT STATE DESIGN

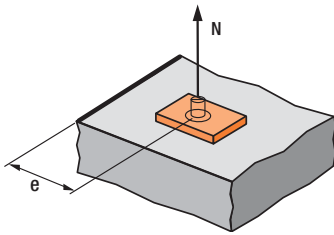

$$X_{ne} = 0.25 + 0.5*(e/h)$$

Where $e_m \leq e \leq e_c$

$$e_c = 1.5*h$$

Note: Tabled values are based on the nominal effective depth, h shown in the installation details. For other values of X_{ne} , please use equation shown above.

Table 2c - Seismic cracked concrete Edge distance effect, X_{ne}

Anchor size, d_b	M10	M12	M16	M20	M24	M30
Edge distance, e (mm)						
45	0.50	0.45				
50	0.53	0.48	0.45			
55	0.56	0.50	0.47	0.41		
60	0.58	0.52	0.49	0.43	0.39	
80	0.69	0.61	0.57	0.49	0.44	0.39
90	0.75	0.66	0.61	0.51	0.46	0.41
100	0.81	0.70	0.65	0.54	0.49	0.43
120	0.92	0.80	0.73	0.60	0.54	0.46
135	1	0.86	0.79	0.65	0.57	0.49
165		1	0.91	0.74	0.64	0.54
187			1	0.80	0.70	0.58
255				1	0.86	0.71
315					1	0.81
420						1

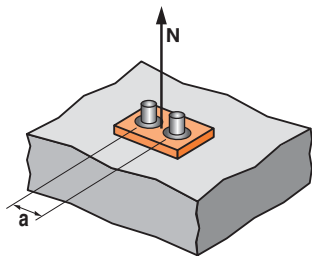

$$X_{na} = 0.5 + a/(6*h)$$

Where $a_m \leq a \leq a_c$

$$a_c = 3*h$$

Note: Tabled values are based on the nominal effective depth, h shown in the installation details. For other values X_{na} , please use equation shown above.

Table 2d - Seismic cracked concrete anchor spacing effect, tension, X_{na}

Anchor size, d_b	M10	M12	M16	M20	M24	M30
Anchor spacing, a (mm)						
50	0.59					
60	0.61	0.59				
75	0.64	0.61	0.60			
90	0.67	0.64	0.62	0.59		
115	0.71	0.67	0.65	0.61	0.59	
130	0.74	0.70	0.67	0.63	0.60	
140	0.76	0.71	0.69	0.64	0.61	0.58
150	0.78	0.73	0.70	0.65	0.62	0.59
200	0.87	0.80	0.77	0.70	0.66	0.62
270	1	0.91	0.86	0.76	0.71	0.66
330		1	0.94	0.82	0.76	0.70
375			1	0.87	0.80	0.72
510				1	0.90	0.80
630					1	0.88
840						1

Checkpoint 2

Design seismic cracked concrete combined pull-out and concrete cone resistance, $N_{Rd,p,seis}$

$$N_{Rd,p,seis} = N_{Rd,p,seis}^0 * X_{ns} * X_{nc} * X_{ne} * X_{na}$$

STEP 3

Verify seismic C1 cracked concrete tensile resistance - per anchor

Table 3a - Seismic Cracked Concrete steel resistance, tensile, $N_{Rd,s,seis} = \alpha_{seis} N_{Rk,s,seis} / \gamma_{Ms}$ (kN) where $\alpha_{seis} = 1.0$

$\gamma_{Ms} = 1.5$ for Grade 5.8 and Grade 8.8 Carbon Steel

$\gamma_{Ms} = 1.73$ for A4 316 Stainless Steel & HCR 1.4529 Stainless Steel

Anchor size, d_b	M10	M12	M16	M20	M24	M30
Grade 5.8 Carbon Steel	18.9	28.1	53.9	81.3	117.8	196.4
Grade 8.8 Carbon Steel	30.9	45.0	83.7	130.7	188.3	299.2
A4 316 Stainless Steel	19.8	29.5	57.7	87.1	126.2	-
HCR 1.4529 Stainless Steel	19.8	29.5	57.7	87.1	126.2	-

Checkpoint 3

Design seismic C1 cracked concrete tensile resistance, $N_{Rd,seis}$

$$N_{Rd,seis} = \text{minimum of } N_{Rd,p,seis}, N_{Rd,s,seis}$$

Check $N^*/N_{Rd,seis} \leq 1$,

if not satisfied return to step 1

ChemSet™ 801 Xtrem™ XC²

STRENGTH LIMIT STATE DESIGN

Seismic Anchors - 801 Xtrem™ XC² - Anchor Studs

STEP 4

Step 4 - Verify seismic C1 cracked concrete edge shear resistance - per anchor

Table 4a - Seismic cracked concrete edge resistance, $V_{Rd,c,seis}^0 = \alpha_{seis} V_{Rk,c,seis}^0 / \gamma_{Mc}$ (kN), $\gamma_{Mc} = 1.5$, $\alpha_{seis} = 0.85$, $f'_c = 30$ MPa

Anchor size, d_n	M10	M12	M16	M20	M24	M30
Effective depth, h (mm)	90	110	125	170	210	280
Edge distance, e_m						
45	1.5	1.7				
50			2.1			
55				2.8		
65					3.5	
70						5.7

Note: Data includes annular gap reduction factor of 0.5

For optimised performance data, please use Ramset iExpert Anchoring Software

Table 4b - Seismic cracked concrete compressive strength effect, shear, X_{vc}

f'_c (MPa)	20	25	30	40	50
X_{vc}	0.82	0.90	1	1.16	1.27

Table 4c - Seismic cracked concrete load direction effect, concrete edge shear, X_{vd}

Angle, α°	0-55	60	70	80	90-180
X_{vd}	1	1.1	1.2	1.5	2

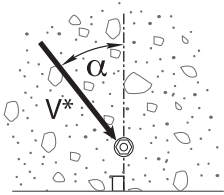

Load direction effect, conc. edge shear, X_{vd}

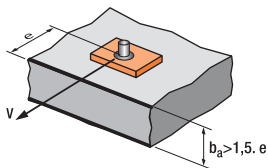

$$X_{ve} = e/e_m * \sqrt{e/e_m}$$

Table 4d - Seismic cracked concrete anchor spacing and edge distance effect, concrete edge shear, X_{ve} For single anchor fastening X_{ve}

e/e_m	1.0	1.2	1.4	1.6	1.8	2.0	2.2	2.4	2.6	2.8	3.0	3.2
X_{ve}	1.00	1.31	1.66	2.02	2.41	2.83	3.26	3.72	4.19	4.69	5.20	5.72

For 2 anchors fastening X_{ve}

e/e_m	1.0	1.2	1.4	1.6	1.8	2.0	2.2	2.4	2.6	2.8	3.0	3.2
a/e_m												
1.0	0.67	0.84	1.03	1.22	1.43	1.65	1.88	2.12	2.36	2.62	2.89	3.16
1.5	0.75	0.93	1.12	1.33	1.54	1.77	2.00	2.25	2.50	2.76	3.03	3.31
2.0	0.83	1.02	1.22	1.43	1.65	1.89	2.12	2.38	2.63	2.90	3.18	3.46
2.5	0.92	1.11	1.32	1.54	1.77	2.00	2.25	2.50	2.77	3.04	3.32	3.61
3.0	1.00	1.20	1.42	1.64	1.88	2.12	2.37	2.63	2.90	3.18	3.46	3.76
3.5		1.30	1.52	1.75	1.99	2.24	2.50	2.76	3.04	3.32	3.61	3.91
4.0			1.62	1.86	2.10	2.36	2.62	2.89	3.17	3.46	3.75	4.05
4.5				1.96	2.21	2.47	2.74	3.02	3.31	3.60	3.90	4.20
5.0					2.33	2.59	2.87	3.15	3.44	3.74	4.04	4.35
5.5						2.71	2.99	3.28	3.71	4.02	4.33	4.65
6.0						2.83	3.11	3.41	3.71	4.02	4.33	4.65

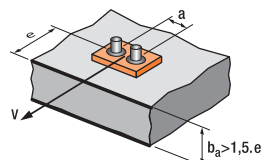

$$X_{ve} = \frac{3 * e + a}{6 * e_m} * \sqrt{e/e_m}$$

For 3 anchors fastening and more

$$X_{ve} = \frac{3 * e + a_1 + a_2 + a_3 + \dots + a_{n-1}}{3 * n * e_m} * \sqrt{e/e_m}$$

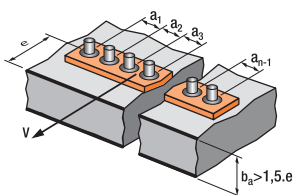

ChemSet™ 801 Xtrem™ XC²

STRENGTH LIMIT STATE DESIGN

Table 4e - Seismic Cracked concrete Pryout failure, $V_{Rd,cp,seis}^0 = \alpha_{seis} V_{Rk,cp,seis} / \gamma_{Mpr}$ (kN), $\gamma_{Mpr} = 1.5$, $\alpha_{seis} = 0.75$, $f'_c = 30$ MPa

Anchor size, d_b	M10	M12	M16	M20	M24	M30
Effective depth, h (mm)	90	110	125	170	210	280
-40 °C to +40 °C	8.8	13.5	19.2	33.1	51.5	76.3
-40 °C to +80 °C	8.8	13.5	19.2	30.4	47.5	70.0

Note: Data includes annular gap reduction factor of 0.5

For single anchor values: Multiply $V_{Rd,cp,seis}^0$ *1.13

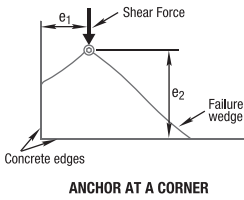

Table 4f Anchor at a corner effect, concrete edge shear, X_{Vs}

Note: For $e_1/e_2 > 1.25$, $X_{Vs} = 1.0$

Edge distance, e_2 (mm)	25	30	35	50	60	75	125	200	300	400	600	900
Edge distance, e_1 (mm)												
25	0.86	0.77	0.70	0.58	0.53	0.49	0.41	0.37	0.35	0.34	0.32	0.32
30	0.97	0.86	0.78	0.64	0.58	0.52	0.43	0.38	0.36	0.34	0.33	0.32
35	1.00	0.95	0.86	0.69	0.63	0.56	0.46	0.40	0.37	0.35	0.33	0.32
50	1.00	1.00	1.00	0.86	0.77	0.67	0.52	0.44	0.39	0.37	0.35	0.33
60	1.00	1.00	1.00	0.97	0.86	0.75	0.57	0.47	0.41	0.38	0.36	0.34
75	1.00	1.00	1.00	1.00	1.00	0.86	0.64	0.51	0.44	0.41	0.37	0.35
125	1.00	1.00	1.00	1.00	1.00	1.00	0.86	0.65	0.53	0.48	0.42	0.38
200	1.00	1.00	1.00	1.00	1.00	1.00	1.00	0.86	0.67	0.58	0.49	0.42
300	1.00	1.00	1.00	1.00	1.00	1.00	1.00	1.00	0.86	0.72	0.58	0.49
400	1.00	1.00	1.00	1.00	1.00	1.00	1.00	1.00	1.00	0.86	0.67	0.55
500	1.00	1.00	1.00	1.00	1.00	1.00	1.00	1.00	1.00	1.00	0.77	0.61
600	1.00	1.00	1.00	1.00	1.00	1.00	1.00	1.00	1.00	1.00	0.86	0.67
900	1.00	1.00	1.00	1.00	1.00	1.00	1.00	1.00	1.00	1.00	1.00	0.86

Checkpoint 4a

Design seismic cracked concrete edge shear resistance, $V_{Rd,c,seis}$
 $= V_{Rd,c,seis}^0 * X_{vc} * X_{vd} * X_{ve} * X_{vs}$

Checkpoint 4b

Design seismic cracked concrete Pryout failure,
 $V_{Rd,cp,seis} = V_{Rd,cp,seis}^0 * X_{nc} * X_{ne} * X_{na}$

STEP 5

Verify seismic C1 cracked concrete shear resistance - per anchor

Table 5a - Seismic Cracked Concrete steel shear resistance, $V_{Rd,s,seis}^R = \alpha_{seis} V_{Rk,s,seis} / \gamma_{Ms}$ (kN)

$\gamma_{Ms} = 1.5$ for Grade 5.8 and Grade 8.8 Carbon Steel

$\gamma_{Ms} = 1.73$ for A4 316 Stainless Steel & HCR 1.4529 Stainless Steel

Anchor size, d_b	M10	M12	M16	M20	M24	M30
Grade 5.8 Carbon Steel	2.8	4.2	8.0	12.1	17.5	29.2
Grade 8.8 Carbon Steel	4.6	6.7	12.5	19.4	28.0	44.5
A4 316 Stainless Steel	2.9	4.4	8.6	13.0	18.8	-
HCR 1.4529 Stainless Steel	2.9	4.4	8.6	13.0	18.8	-

Note: Data includes annular gap reduction factor of 0.5

For single anchor values: Multiply $V_{Rd,s,seis}$ *1.17

Checkpoint 5

Design seismic C1 cracked concrete shear resistance, $V_{Rd,seis}$

$V_{Rd,seis} = \text{minimum of } V_{Rd,c,seis}, V_{Rd,cp,seis}, V_{Rd,s,seis}$

Check $V^*/V_{Rd,seis} \leq 1$,

if not satisfied return to step 1

ChemSet™ 801 Xtrem™ XC²

STRENGTH LIMIT STATE DESIGN

STEP 6 Combined Loading

Checkpoint 6

Check

$$N^*/N_{Rd,seis} + V^*/V_{Rd,seis} \leq 1.0,$$
 if not satisfied return to step 1

Specify - Threaded Stud Anchors
 Ramset™ 801 Xtrem™ XC² with (Anchor Size) grade 5.8 ChemSet™ Anchor Stud (Anchor Stud Part Number) Drilled Hole Depth to be (h) mm.

Example
 Ramset™ 801 Xtrem™ XC² Injection with M16 grade 5.8 ChemSet™ Anchor Stud (CS16190GH). Drilled hole depth to be 125mm. To be installed according to Ramset™ Installation Instructions.

Use Ramset™ iExpert Anchor Software for optimised calculation or where a greater range of anchor layout detail is needed.

ChemSet™ 801 Xtrem™ XC²

SEISMIC Xtrem™ ANCHOR STUDS - CHEMICAL INJECTION

[Back to index](#)

GENERAL INFORMATION

Performance Related	Material Specification	Installation Related

Product

ChemSet™ 801 Xtrem™ XC² is a heavy duty Vinylester adhesive for anchoring threaded studs and reinforcing bar into cracked and uncracked concrete.



Compliance

European Technical Assessment (option 1) - ETA-18/0045

Design according to:

- AS5216 (formerly TS101)
- AS1170.4 - Earthquake Actions
- EN1992-4 (formerly ETAG001 Annex C, E & TR045)
- NZS3101 (A3) Section 17 - Seismic Design C2
- Use enclosed data for simplified calculation method

Use Ramset™ iExpert Anchor Software for optimised calculation or where a greater range of anchor layout detail is needed

Benefits, Advantages and Features

- 50 year working life
- Greater productivity:**
 - Easy dispensing even in cold weather
 - Apply torque in 2 hours @ 20°C
- Greater security:**
 - Strong bond
 - Rated for sustained loading
- Versatile:**
 - Earthquake, Fire & Flooded Conditions
 - Cold and temperate climates
- Greater safety:**
 - Low odour
 - Suitable for contact with drinking water
 - VOC Compliant



Principal Applications

- Threaded Studs
- Starter Bars
- Threaded Inserts
- Over-head installation
- Steel Columns
- Hand Rails
- Road Stitching

Recommended Installation Temperatures

	Minimum	Maximum
Substrate	5°C	40°C
Adhesive	5°C	40°C

Service Temperature Limits

-40°C to 80°C

Setting Times

Temperature of base material	Gel Time	Curing time in dry concrete	Curing time in wet concrete
+5°C	60 min	240 min	480 min
6°C - 10°C	40 min	180 min	360 min
11°C - 20°C	15 min	120 min	240 min
21°C - 30°C	8 min	90 min	180 min
31°C - 40°C	4 min	60 min	120 min

Note: Cartridge temperature minimum +5°C

NOTE: For C2 Certified Performance, only use Anchor Stud Xtrem™ (Multicone) anchors with ChemSet™ 801 Xtrem™ XC².

Installation

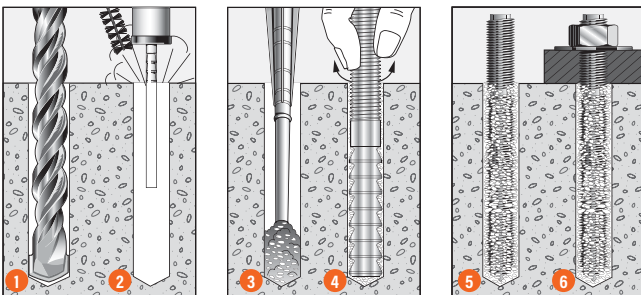

1. Drill recommended diameter and depth hole.
2. **Important:** Use Ramset Dustless Drilling System to ensure holes are clean. Alternatively clean dust and debris from hole with stiff wire or nylon brush and blower in the following sequence: blow x 2, brush x 2, blow x 2.
3. Dispense adhesive to waste until colour is uniform light grey (2-3 trigger pulls). Insert mixing nozzle to bottom of hole. Fill hole to 3/4 the hole depth slowly, ensuring no air pockets form.
4. Insert Ramset™ ChemSet™ Anchor Stud/rebar to bottom of hole while turning.
5. Allow Chemset™ 801 Xtrem™ XC² to cure as per setting times.
6. Attach fixture.

ChemSet™ 801 Xtrem™ XC²

SEISMIC Xtrem™ ANCHOR STUDS - CHEMICAL INJECTION

Installation and performance details: ChemSet™ 801 Xtrem™ XC² and ChemSet™ Anchor Stud Xtrem™ (Multicone)

Anchor size, d _b (mm)	Drilled hole diam. , d _h (mm)	Fixture hole diameter, d _r (mm)	Anchor effective depth, h (mm)	Tightening torque, T _r (Nm)	Optimum dimensions*		
					Anchor spacing, a _c (mm)	Edge distance, e _c (mm)	Concrete substrate thickness, b _m (mm)
M12	14	14	60	30	180	90	120
M16	18	18	96	50	288	144	180
M20	22	22	100	150	300	150	200

* Note: For shear loads acting towards an edge or where these optimum dimensions are not achievable, please use the simplified strength limit state design process to verify capacity.

Anchor size, d _b (mm)	Reduced Characteristic Capacity				
	Grade 8.8 Xtrem™ Steel Studs		Seismic Cracked Concrete C2		
	Shear, V _{Rd,seis} (kN)	Tension, N _{Rd,s,seis} (kN)***	Tension, N _{Rd,p,seis} (kN)**		
			Concrete Compressive Strength, f' _c		
			20 MPa	30 MPa	40 MPa
M12	8.0	33.3	8.0	9.8	10.4
M16	15.0	59.3	16.1	19.8	22.8
M20	23.3	93.3	17.1	21.1	24.3

**Note: Seismic Cracked concrete combined pull-out and concrete cone resistance, tension = $N_{Rd,p,seis}^0 = \alpha_{Nseis} N_{Rk,p,seis}^0 / \gamma_{Msp}$ where $\gamma_{Msp} = 1.5$, $\alpha_{Nseis} = 0.85$

***Note: Seismic Cracked Concrete steel resistance, tension = $N_{Rd,s,seis} = \alpha_{Nseis} N_{Rk,s,seis}^0 / \gamma_{Ms}$ (Kn) where $\gamma_{Ms} = 1.5$ (Grade 8.8 steel), $\alpha_{Nseis} = 1.0$

For optimised performance data, please use Ramset iExpert Anchoring Software.

DESCRIPTION AND PART NUMBERS

Description	Cartridge Size	Part No.
ChemSet™ 801 Xtrem™ XC ²	750ml	C801X750 (AU & NZ)
ChemSet™ 801 Xtrem™ XC ²	380ml	C801X380 (AU Only)

Description	Anchor Size	Part No.
ChemSet™ Xtrem™ Anchor Stud M12 x 150mm Zinc	M12	CS12150XT
ChemSet™ Xtrem™ Anchor Stud M16 x 200mm Zinc	M16	CS16200XT
ChemSet™ Xtrem™ Anchor Stud M20 x 270mm Zinc	M20	CS20270XT

ENGINEERING PROPERTIES

ChemSet™ Anchor Studs Xtrem™

Anchor Size, d _b	Grade 8.8 Anchor stud Xtrem™				Section modulus Z (mm ³)
	Shank diameter, d _s (mm)	Stressed Area (mm ²)	Yield Strength f _y MPa	UTS f _u MPa	
M12	8.9	62.5	640	800	109.2
M16	11.9	111.2	640	800	277.5
M20	14.9	175	640	800	540.9

ChemSet™ 801 Xtrem™ XC²

STRENGTH LIMIT STATE DESIGN

STEP 1

Select anchor to be evaluated

Table 1a Indicative combined loading - interaction diagram

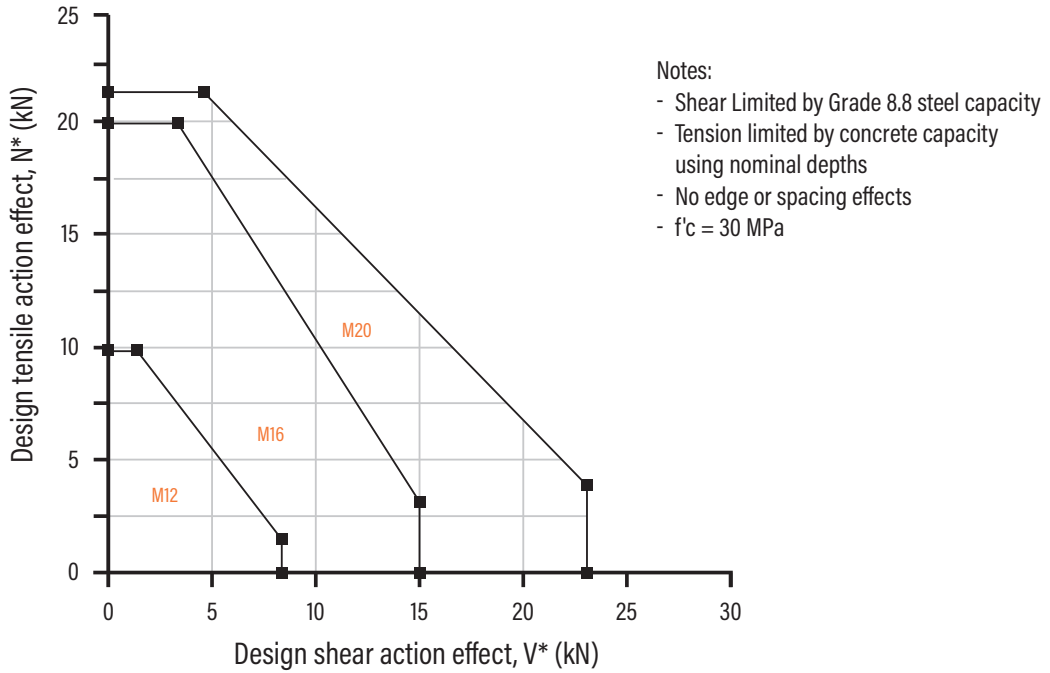

Table 1b Absolute minimum edge distance and anchor spacing values, e_m and a_m (mm)

Anchor size, d _b M10	M12	M16	M20
Min. Anchor Spacing - a _m	55	60	120
Min. Edge Distance - e _m	55	60	120

Step 1c Calculate anchor effective depth, h (mm)

Effective depth, h (mm)

Preferred $h = h_n$ otherwise,

$h = L_e - t$

t = total thickness of material(s) being fastened.

Substrate thickness, b_m (mm)

$b_m = 2 \times h$

Checkpoint 1

Anchor size determined, absolute minima compliance achieved, effective depth (h) calculated.

ChemSet™ 801 Xtrem™ XC²

STRENGTH LIMIT STATE DESIGN

Seismic Anchors - 801 Xtrem™ XC² Anchor Studs Xtrem™

STEP 2 Verify Seismic C2 cracked concrete tensile capacity - per anchor

Table 2a - Seismic C2 Cracked concrete combined Pull-out and concrete cone resistance, tension

$N_{Rd,p,seis}^0 = \alpha_{seis} N_{Rk,p,seis}^0 / \gamma_{Msp}$ (kN), $\gamma_{Msp} = 1.5$, $\alpha_{N,seis} = 0.85$, $f'_c = 30$ MPa
 where $N_{Rk,p,seis}^0 = \pi * d_b * h * \tau_{Rk,cr,seis}$

Anchor Size, d_b	M12	M16	M20
Drilled Hole Dia, d_h (mm)	14	18	22
Effective Depth, h (mm)			
60	9.8		
96		19.8	
100			21.1

Flooded Holes: Multiply $N_{Rd,p,seis}^0$ *1.0

For single anchor values: Multiply $N_{Rd,p,seis}^0$ *1.17

For optimised performance data, including deeper effective depths, please use Ramset iExpert Anchoring Software.

Table 2b-1 Seismic Cracked concrete service temperature limits effect, tension, X_{ns}

Service temperature (°C)	X_{ns}
-40°C to +40°C	1.00
-40°C to +80°C	0.93

Table 2b-2 Seismic Cracked concrete compressive strength effect, tension, X_{nc}

Anchor size, d_b	Concrete compressive strength effect, tension, X_{nc}		
	M12	M16	M20
f'_c (MPa)			
20	0.81	0.81	0.81
25	0.91	0.91	0.91
30	1.00	1.00	1.00
40	1.06	1.15	1.15
50	1.10	1.29	1.29

ChemSet™ 801 Xtrem™ XC²

STRENGTH LIMIT STATE DESIGN

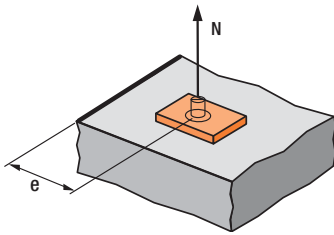

$$X_{ne} = 0.25 + 0.5 \cdot (e/h)$$

Where $e_m \leq e \leq e_c$

$$e_c = 1.5 \cdot h$$

Note: Tabled values are based on the nominal effective depth, h shown in the installation details. For other values of X_{ne} , please use equation shown above.

Table 2c - Seismic cracked concrete Edge distance effect, tension, X_{ne}

Anchor size, d_b	M12	M16	M20
Edge distance, e (mm)			
55	0.71		
60	0.75	0.56	
80	0.92	0.67	
90	1.00	0.72	
100		0.77	
110		0.82	
120		0.88	0.85
135		0.95	0.93
145		1.00	0.98
150			1.00

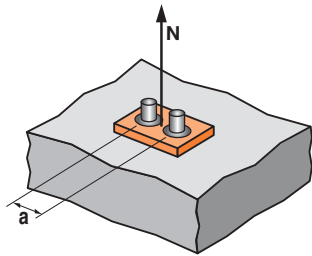

$$X_{na} = 0.5 + a/(6 \cdot h)$$

Where $a_m \leq a \leq a_c$

$$a_c = 3 \cdot h$$

Note: Tabled values are based on the nominal effective depth, h shown in the installation details. For other values of X_{na} , please use equation shown above.

Table 2d - Seismic cracked concrete anchor spacing effect, tension, X_{na}

Anchor size, d_b	M12	M16	M20
Anchor spacing, a (mm)			
55	0.65		
60	0.67	0.60	
80	0.72	0.64	
90	0.75	0.66	
100	0.78	0.67	
110	0.81	0.69	
120	0.83	0.71	0.70
150	0.92	0.76	0.75
165	0.96	0.79	0.78
185	1.00	0.81	0.80
250		0.93	0.92
290		1.00	0.98
300			1.00

Checkpoint 2

Design seismic cracked concrete combined pull-out and concrete cone resistance, $N_{Rd,p,seis}$

$$N_{Rd,p,seis} = N_{Rd,p,seis}^0 \cdot X_{ns} \cdot X_{nc} \cdot X_{ne} \cdot X_{na}$$

STEP 3

Verify seismic C2 cracked concrete tensile resistance - per anchor

Table 3a - Seismic Cracked Concrete steel resistance, tensile, $N_{Rd,s,seis} = \alpha_{seis} \cdot N_{Rk,s,seis} / \gamma_{Ms}$ (kN)

where $\alpha_{seis} = 1.0$ $\gamma_{Ms} = 1.5$

Anchor size, d_b	M12	M16	M20
Grade 8.8 Anchor Stud Xtrem™	33.3	59.3	93.3

Checkpoint 3

Design seismic C2 cracked concrete tensile resistance, $N_{Rd,seis}$

$$N_{Rd,seis} = \text{minimum of } N_{Rd,p,seis} \text{ and } N_{Rd,s,seis}$$

Check $N^*/N_{Rd,seis} \leq 1$,

if not satisfied return to step 1

ChemSet™ 801 Xtrem™ XC²

STRENGTH LIMIT STATE DESIGN

Seismic Anchors - 801 Xtrem™ XC² Anchor Studs Xtrem™

STEP 4

Step 4 - Verify seismic C2 cracked concrete edge shear resistance - per anchor

Table 4a - Seismic cracked concrete edge resistance, $V_{Rd,c,seis}^0 = \alpha_{seis} V_{Rk,c,seis}^0 / \gamma_{Mc}$ (kN), $\gamma_{Mc} = 1.5$,
 $\alpha_{seis} = 0.85$, $f'_c = 30$ MPa

Anchor size, d_b	M12	M16	M20
Effective depth, h (mm)	60	96	100
Edge distance, e_m			
55	1.9		
60		2.5	
120			6.3

Note: Data includes annular gap reduction factor of 0.5

For optimised performance data, please use Ramset iExpert Anchoring Software.

Table 4b - Seismic cracked concrete compressive strength effect, shear, X_{vc}

f'_c (MPa)	20	25	30	40	50
X_{vc}	0.82	0.90	1	1.16	1.27

Table 4c - Seismic cracked concrete load direction effect, concrete edge shear, X_{vd}

Angle, α°	0-55	60	70	80	90-180
X_{vd}	1	1.1	1.2	1.5	2

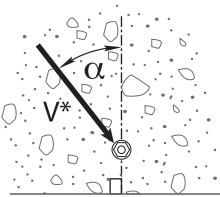

Load direction effect, conc. edge shear, X_{vd}

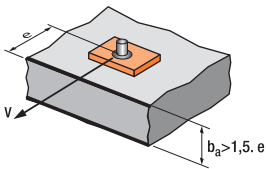

$$X_{ve} = e/e_m * \sqrt{e/e_m}$$

Table 4d - Seismic cracked concrete anchor spacing and edge distance effect, concrete edge shear, X_{ve}

For single anchor fastening X_{ve}

e/e_m	1.0	1.2	1.4	1.6	1.8	2.0	2.2	2.4	2.6	2.8	3.0	3.2
X_{ve}	1.00	1.31	1.66	2.02	2.41	2.83	3.26	3.72	4.19	4.69	5.20	5.72

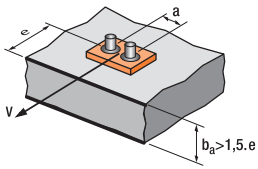

$$X_{ve} = \frac{3*e + a}{6*e_m} * \sqrt{e/e_m}$$

For 2 anchors fastening X_{ve}

e/e_m	1.0	1.2	1.4	1.6	1.8	2.0	2.2	2.4	2.6	2.8	3.0	3.2
a/e_m												
1.0	0.67	0.84	1.03	1.22	1.43	1.65	1.88	2.12	2.36	2.62	2.89	3.16
1.5	0.75	0.93	1.12	1.33	1.54	1.77	2.00	2.25	2.50	2.76	3.03	3.31
2.0	0.83	1.02	1.22	1.43	1.65	1.89	2.12	2.38	2.63	2.90	3.18	3.46
2.5	0.92	1.11	1.32	1.54	1.77	2.00	2.25	2.50	2.77	3.04	3.32	3.61
3.0	1.00	1.20	1.42	1.64	1.88	2.12	2.37	2.63	2.90	3.18	3.46	3.76
3.5		1.30	1.52	1.75	1.99	2.24	2.50	2.76	3.04	3.32	3.61	3.91
4.0			1.62	1.86	2.10	2.36	2.62	2.89	3.17	3.46	3.75	4.05
4.5				1.96	2.21	2.47	2.74	3.02	3.31	3.60	3.90	4.20
5.0					2.33	2.59	2.87	3.15	3.44	3.74	4.04	4.35
5.5						2.71	2.99	3.28	3.71	4.02	4.33	4.65
6.0						2.83	3.11	3.41	3.71	4.02	4.33	4.65

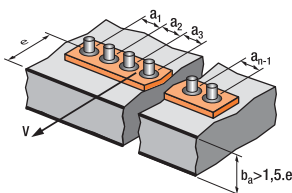

For 3 anchors fastening and more

$$X_{ve} = \frac{3*e + a_1 + a_2 + a_3 + \dots + a_{n-1}}{3*n*e_m} * \sqrt{e/e_m}$$

ChemSet™ 801 Xtrem™ XC²

STRENGTH LIMIT STATE DESIGN

Seismic Anchors - 801 Xtrem™ XC² Anchor Studs Xtrem™

Table 4e - Seismic Cracked concrete Pryout failure, $V_{Rd,cp,seis}^0 = \alpha_{seis} V_{Rk,cp,seis} / \gamma_{Mpr}$ (kN), $\gamma_{Mpr} = 1.5$, $\alpha_{seis} = 0.75$, $f'_c = 30$ MPa

Anchor size, d_b	M12	M16	M20
Effective depth, h (mm)	60	96	100
-40 °C to +40 °C	8.7	19.8	21.1
-40 °C to +80 °C	8.1	18.4	19.6

Note: Data includes annular gap reduction factor of 0.5

For single anchor values: Multiply $V_{Rd,cp,seis}^0$ *1.13

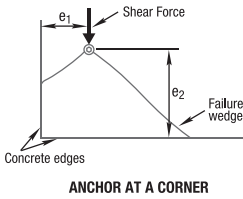

Table 4f Anchor at a corner effect, seismic concrete edge shear, X_{VS}

Note: For $e_1/e_2 > 1.25$, $X_{VS} = 1.0$

Edge distance, e_2 (mm)	25	30	35	50	60	75	125	200	300	400	600	900
Edge distance, e_1 (mm)												
25	0.86	0.77	0.70	0.58	0.53	0.49	0.41	0.37	0.35	0.34	0.32	0.32
30	0.97	0.86	0.78	0.64	0.58	0.52	0.43	0.38	0.36	0.34	0.33	0.32
35	1.00	0.95	0.86	0.69	0.63	0.56	0.46	0.40	0.37	0.35	0.33	0.32
50	1.00	1.00	1.00	0.86	0.77	0.67	0.52	0.44	0.39	0.37	0.35	0.33
60	1.00	1.00	1.00	0.97	0.86	0.75	0.57	0.47	0.41	0.38	0.36	0.34
75	1.00	1.00	1.00	1.00	1.00	0.86	0.64	0.51	0.44	0.41	0.37	0.35
125	1.00	1.00	1.00	1.00	1.00	1.00	0.86	0.65	0.53	0.48	0.42	0.38
200	1.00	1.00	1.00	1.00	1.00	1.00	1.00	0.86	0.67	0.58	0.49	0.42
300	1.00	1.00	1.00	1.00	1.00	1.00	1.00	1.00	0.86	0.72	0.58	0.49
400	1.00	1.00	1.00	1.00	1.00	1.00	1.00	1.00	1.00	0.86	0.67	0.55
500	1.00	1.00	1.00	1.00	1.00	1.00	1.00	1.00	1.00	1.00	0.77	0.61
600	1.00	1.00	1.00	1.00	1.00	1.00	1.00	1.00	1.00	1.00	0.86	0.67
900	1.00	1.00	1.00	1.00	1.00	1.00	1.00	1.00	1.00	1.00	1.00	0.86

Checkpoint 4a

Design seismic cracked concrete edge shear resistance, $V_{Rd,c,seis}$

$$= V_{Rd,c,seis}^0 * X_{vc} * X_{vd} * X_{ve} * X_{vs}$$

Checkpoint 4b

Design seismic cracked concrete Pryout failure,

$$V_{Rd,cp,seis} = V_{Rd,cp,seis}^0 * X_{nc} * X_{ne} * X_{na}$$

STEP 5

Verify seismic C2 cracked concrete shear resistance - per anchor

Table 5a - Seismic Cracked Concrete steel shear resistance, $V_{Rd,s,seis}^0 = \alpha_{seis} V_{Rk,s,seis} / \gamma_{Ms}$ (kN), $\gamma_{Ms} = 1.25$ for Grade 8.8 Anchor Stud Xtrem™

Anchor size, d_b	M12	M16	M20
Grade 8.8 Multicone	8.0	15.0	23.3

Note: Data includes annular gap reduction factor of 0.5

For single anchor values: Multiply $V_{Rd,s,seis}^0$ *1.17

Note: Apply reduction factor of 0.5 when using Hot Dip Galvanised Anchor Stud Xtrem™

Checkpoint 5

Design seismic C2 cracked concrete shear resistance, $V_{Rd,seis}$

$$V_{Rd,seis} = \text{minimum of } V_{Rd,c,seis}, V_{Rd,cp,seis}, V_{Rd,s,seis}$$

Check $V^*/V_{Rd,seis} \leq 1$,
 if not satisfied return to step 1

ChemSet™ 801 Xtrem™ XC²

STRENGTH LIMIT STATE DESIGN

Seismic Anchors - 801 Xtrem™ XC² Anchor Studs Xtrem™

STEP 6 Combined Loading

Checkpoint 6

Check
 $N^*/N_{Rd,seis} + V^*/V_{Rd,seis} \leq 1.0,$
 if not satisfied return to step 1

Specify - Threaded Multicone Stud Anchors
 Ramset™ 801 Xtrem™ XC² with (Anchor Size) grade 8.8 ChemSet™ Anchor Stud Xtrem™ (Anchor Stud Part Number) Drilled Hole Depth to be (h) mm.

Example
 Ramset™ 801 Xtrem™ XC² Injection with M16 grade 8.8 ChemSet™ Anchor Stud Xtrem™ (C16200XT). Drilled hole depth to be 125mm. To be installed according to Ramset™ Installation Instructions.

Tension - Sustained loading

Displacements under seismic tension loading, seismic performance category C2 for CHEMSET™ Xtrem™

Concrete Strength $f_c = 20\text{MPa}$ (-40°C to +80°C)

CHEMSET™ Xtrem™			M12	M16	M20
Displacement DLS	$\delta_{N,eq}$ (DLS)	[mm]	0.72	0.98	1.15
Displacement ULS	$\delta_{N,eq}$ (ULS)	[mm]	1.65	2.07	3.20

DLS = Damage Limit State
 ULS = Ultimate Limit State

Shear - Sustained loading

Displacements under seismic shear loading, seismic performance category C2 for CHEMSET™ Xtrem™

Concrete Strength $f_c = 20\text{MPa}$ (-40°C to +80°C)

CHEMSET™ Xtrem™			M12	M16	M20
Displacement DLS	$\delta_{V,eq}$ (DLS)	[mm]	2.01	2.63	2.99
Displacement ULS	$\delta_{V,eq}$ (ULS)	[mm]	3.57	4.67	4.53

DLS = Damage Limit State
 ULS = Ultimate Limit State

Use Ramset™ iExpert Anchor Software for optimised calculation or where a greater range of anchor layout detail is needed.

ChemSet™ 801 Xtrem™ XC²

SEISMIC REINFORCING BAR - CHEMICAL INJECTION

[Back to index](#)

GENERAL INFORMATION

Performance Related	Installation Related

Product

ChemSet™ 801 Xtrem™ XC² is a heavy duty Vinylester adhesive for anchoring threaded studs and reinforcing bar into cracked and uncracked concrete.



Compliance

European Technical Assessment (option 1) - ETA-18/0045

Design according to:

- AS5216 (formerly TS101)
- AS1170.4 - Earthquake Actions
- EN1992-4 (formerly ETAG001 Annex C, E & TR045)
- NZS3101 (A3) Section 17 - Seismic Design C1
- Use enclosed data for simplified calculation method

Use Ramset™ iExpert Anchor Software for optimised calculation or where a greater range of anchor layout detail is needed.



Benefits, Advantages and Features

- 50 year working life
- Greater productivity:**
 - Easy dispensing even in cold weather
 - Apply torque in 2 hours @ 20°C
- Greater security:**
 - Strong bond
 - Rated for sustained loading
- Versatile:**
 - Earthquake, Fire & Flooded Conditions
 - Cold and temperate climates
- Greater safety:**
 - Low odour
 - Suitable for contact with drinking water
 - VOC Compliant

Made in Australia

Installation

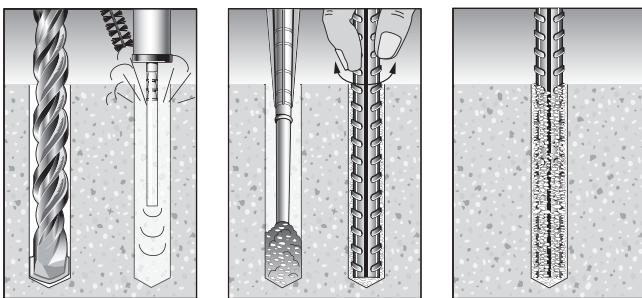

1. Drill or core hole to specified diameter and depth
2. **Important:** Use Ramset™ Dustless Drilling System to ensure holes are clean. Alternatively, clean dust and debris from hole with stiff wire or nylon brush and blower in the following sequence: blow x 2, brush x 2, blow x 2.
3. Screw mixing nozzle onto cartridge and dispense 2-3 trigger pulls of adhesive to waste until colour is grey with no streaks
4. Insert tip of nozzle to bottom of hole and dispense adhesive
5. Fill hole to about 2/3 full
6. Insert reinforcing bar with rotating motion to release trapped air
7. Wait until adhesive has fully cured before loading (see Working Time / Loading Time chart)
8. Clean up with Acetone

Principal Applications

- Threaded Studs
- Starter Bars
- Threaded Inserts
- Over-head installation
- Steel Columns
- Hand Rails
- Road Stitching

Recommended Installation Temperatures

	Minimum	Maximum
Substrate	5°C	40°C
Adhesive	5°C	40°C

Service Temperature Limits

-40°C to 80°C

Setting Times

Temperature of base material	Gel Time	Curing time in dry concrete	Curing time in wet concrete
+5°C	60 min	240 min	480 min
6°C - 10°C	40 min	180 min	360 min
11°C - 20°C	15 min	120 min	240 min
21°C - 30°C	8 min	90 min	180 min
31°C - 40°C	4 min	60 min	120 min

Note: Cartridge temperature minimum +5°C

Seismic Anchors - 801 Xtrem™ XC² - Reinforcing Bar

ChemSet™ 801 Xtrem™ XC²

SEISMIC REINFORCING BAR - CHEMICAL INJECTION

Installation and performance details: ChemSet™ 801 Xtrem™ XC² and Reinforcing Bar

Anchor Size, d _a (mm)	Drilled Hole diam., d _h (mm)	Anchor Effective Depth, h (mm)	Optimum dimensions*		Concrete substrate thickness, b _m (mm)	Gr 500 Rebar - Steel		Seismic C1 Cracked Concrete reduced characteristic tensile capacity, N ⁰ _{Rd,p,seis} (kN)**
			Edge* distance, e _c (mm)	Anchor* spacing, a _c (mm)		Tension, N _{Rd,s,seis} (kN)***	Shear, φV _{Rd,s,seis} (kN)	
								10
12	15	110	330	165	140	44.2	14.5	12.9
16	20	125	375	187	160	78.7	25.8	19.6
20	25	170	510	255	220	122.9	40.4	36.3

** For anchor spacings or edge distances less than the minimum, please refer to the simplified strength limit state design process to verify capacity.
 ** Tension values are based on service temperature limits -40 °C to +40 °C only. If service temperature limits is beyond this range please contact Ramset Engineer.
 ** Note: Seismic Cracked concrete combined pull-out and concrete cone resistance, tension = $N_{Rd,p,seis}^0 = \alpha_{Nseis} N_{Rk,p,seis}^0 / \gamma_{Msp}$ where $\gamma_{Msp} = 1.5$, $\alpha_{Nseis} = 0.85$
 *** Note: Seismic Cracked Concrete steel resistance, tension = $N_{Rd,s,seis} = \alpha_{Nseis} N_{Rk,s,seis}^0 / \gamma_{Ms}$ (kN) where $\gamma_{Ms} = 1.38$

Flooded Holes: Multiply N⁰_{Rd,p,seis} *0.9
For single anchor values: Multiply N⁰_{Rd,p,seis} *1.17
For optimised performance data, please use Ramset iExpert Anchoring Software.

DESCRIPTION AND PART NUMBERS

Description	Cartridge Size	Part No.
ChemSet™ 801 Xtrem™ XC ²	750ml	C801X750 (AU & NZ)
ChemSet™ 801 Xtrem™ XC ²	380ml	C801X380 (AU Only)

Drilled hole depth, h ₁ (mm) h ₁ = h h = Effective depth
--

Substrate thickness, b _m (mm)			
Reinforcing Bar Size			
10	12	16	20
h + 30mm ≥ 100mm		h + (2 x d _a)	

ENGINEERING PROPERTIES

Typical Engineering Properties of Grade 500 Reinforcing Bar

Rebar Size	10	12	16	20
Drilled Hole Dia, d _h (mm)	12	15	20	25
Stress Area, A _s (mm ²)	78.5	113	201	314
Yield Stress, f _{sy} (MPa)	500	500	500	500
Tensile Steel Yield Capacity, N _{sy} (kN)	39.3	56.5	100.5	157.0

For further information refer to reinforcing bar manufacturer's published information and current revision of AS/NZS4671

ChemSet™ 801 Xtrem™ XC²

STRENGTH LIMIT STATE DESIGN

STEP 1

Select anchor to be evaluated

Table 1a Indicative combined loading - interaction diagram

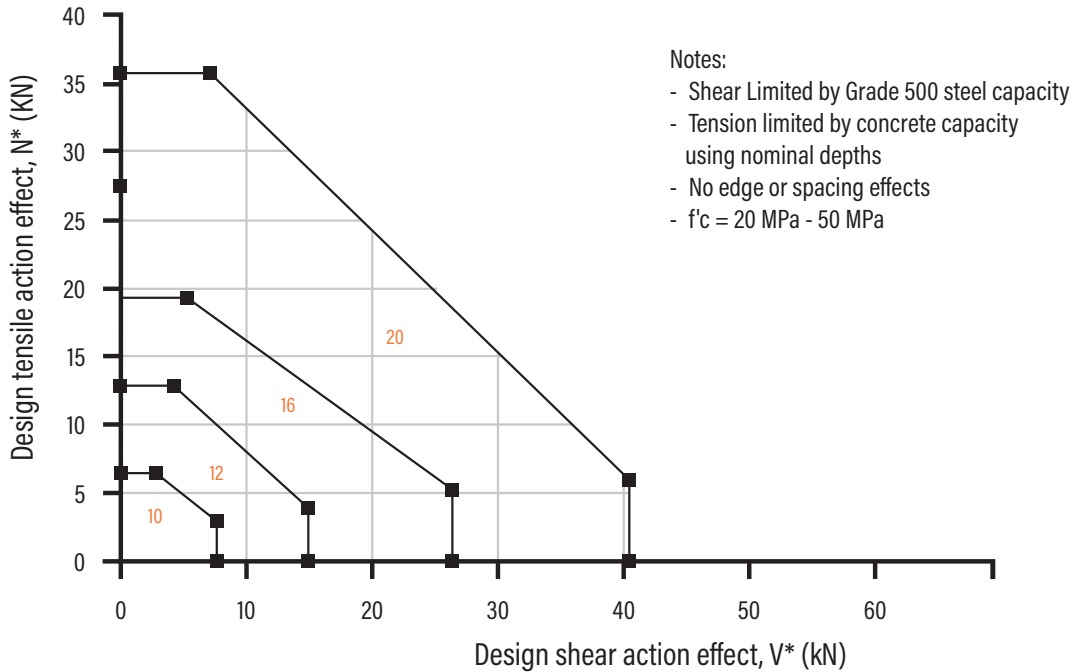

Table 1b Absolute minimum edge distance and anchor spacing values, e_m and a_m (mm)

Anchor size, d_b	10	12	16	20
Min. Anchor Spacing - a_m	50	60	80	100
Min. Edge Distance - e_m	45	45	50	65

Step 1c Calculate anchor effective depth, h (mm)

Refer to nominal recommended effective depths, h , listed in installation and performance details in the SARB ANZ on the previous page.

Substrate thickness, b_m (mm)			
Reinforcing Bar Size			
10	12	16	20
$h + 30\text{mm} \geq 100\text{mm}$		$h + (2 \times d_b)$	

Checkpoint 1

Anchor size determined, absolute minima compliance achieved, effective depth (h) calculated.

ChemSet™ 801 Xtrem™ XC²

STRENGTH LIMIT STATE DESIGN

Seismic Anchors - 801 Xtrem™ XC² - Reinforcing Bar

STEP 2 Verify Seismic C1 cracked concrete tensile capacity - per anchor

Table 2a - Seismic Cracked concrete combined Pull-out and concrete cone resistance, tension

$$N_{Rd,p,seis}^0 = \alpha_{seis} N_{Rk,p,seis}^0 / \gamma_{Msp} \text{ (kN)}, \gamma_{Msp} = 1.5, \alpha_{N,seis} = 0.85, f'_c = 30 \text{ MPa}$$

$$\text{where } N_{Rk,p,seis}^0 = \pi * d_b * h * \tau_{Rk,cr,seis}$$

Anchor Size, d _b	10	12	16	20
Drilled Hole Dia, d _h (mm)	12	15	20	25
Effective Depth, h (mm)				
70	4.7			
80	5.4			
90	6.1	10.6		
100	6.8	11.7		
110	7.4	12.9	17.2	
120	8.1	14.1	18.8	
125	8.5	14.7	19.6	
140	9.5	16.4	21.9	
150	10.1	17.6	23.5	32.0
160	10.8	18.8	25.1	34.2
170	11.5	20.0	26.6	36.3
180	12.2	21.1	28.2	38.5
190	12.9	22.3	29.8	40.6
200	13.5	23.5	31.3	42.7
210		24.7	32.9	44.9
240		28.2	37.6	51.3
280			43.9	59.8
320			50.1	68.4
350				74.8
400				85.5

Bold values are at ChemSet Rebar Anchor nominal depths

Note: The maximum embedment depth shall be reduced to 12d_b for installation in flooded holes

Flooded Holes: Multiply N_{Rd,p,seis}⁰ *0.9

For single anchor values: Multiply N_{Rd,p,seis}⁰ *1.17

For optimised performance data, please use Ramset iExpert Anchoring Software.

Table 2b-1 Seismic Cracked concrete service temperature limits effect, tension, X_{ns}

Anchor size, d _b	Service temperature limits effect, tension, X _{ns}			
	M10	M12	M16	M20
Service temperature (°C)				
-40°C to +40°C	1.00	1.00	1.00	1.00
-40°C to +80°C	1.00	1.00	1.00	1.00

Table 2b-2 Seismic Cracked concrete compressive strength effect, tension, X_{nc}

f'c (MPa)	20	25	30	40	50
X _{nc}	1.0	1.0	1.0	1.0	1.0

ChemSet™ 801 Xtrem™ XC²

STRENGTH LIMIT STATE DESIGN

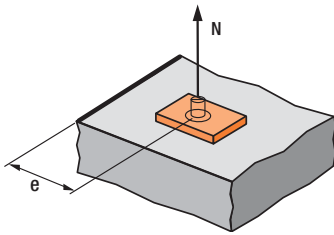

$$X_{ne} = 0.25 + 0.5 \cdot (e/h)$$

Where $e_m \leq e \leq e_c$

$$e_c = 1.5 \cdot h$$

Note: Tabled values are based on the nominal effective depth, h shown in the installation details. For other values of X_{ne} , please use equation shown above.

Table 2c - Seismic cracked concrete Edge distance effect, tension, X_{ne}

Anchor size, d_b	10	12	16	20
Edge distance, e (mm)				
45	0.50	0.45		
50	0.53	0.48	0.45	
65	0.61	0.55	0.51	0.44
85	0.72	0.64	0.59	0.50
90	0.75	0.66	0.61	0.51
100	0.81	0.70	0.65	0.54
120	0.92	0.80	0.73	0.60
135	1	0.86	0.79	0.65
165		1	0.91	0.74
187			1	0.80
255				1

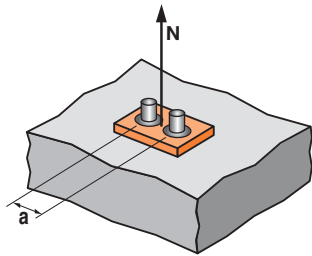

$$X_{na} = 0.5 + a/(6 \cdot h)$$

Where $a_m \leq a \leq a_c$

$$a_c = 3 \cdot h$$

Note: Tabled values are based on the nominal effective depth, h shown in the installation details. For other values X_{na} , please use equation shown above.

Table 2d - Seismic cracked concrete anchor spacing effect, tension, X_{na}

Anchor size, d_b	10	12	16	20
Anchor spacing, a (mm)				
50	0.59			
60	0.61	0.59		
80	0.65	0.62	0.61	
100	0.69	0.65	0.63	0.60
120	0.72	0.68	0.66	0.62
150	0.78	0.73	0.70	0.65
200	0.87	0.80	0.77	0.70
270	1	0.91	0.86	0.76
330		1	0.94	0.82
375			1	0.87
510				1

Checkpoint 2

Design seismic cracked concrete combined pull-out and concrete cone resistance, $N_{Rd,p,seis}$

$$N_{Rd,p,seis} = N_{Rd,p,seis}^0 \cdot X_{ns} \cdot X_{nc} \cdot X_{ne} \cdot X_{na}$$

STEP 3

Verify seismic C1 cracked concrete tensile resistance - per anchor

Table 3a - Seismic Cracked Concrete steel resistance, tensile, $N_{Rd,s,seis} = \alpha_{seis} N_{Rk,s,seis} / \gamma_{Ms}$ (kN)

where $\alpha_{seis} = 1.0$, $\gamma_{Ms} = 1.38$ for Grade 500 Rebar

Anchor size, d_b	10	12	16	20
Grade 500 Rebar	30.7	44.2	78.7	122.9

Checkpoint 3

Design seismic C1 cracked concrete tensile resistance, $N_{Rd,seis}$

$$N_{Rd,seis} = \text{minimum of } N_{Rd,p,seis} / N_{Rd,s,seis}$$

Check $N^*/N_{Rd,seis} \leq 1$,

if not satisfied return to step 1

ChemSet™ 801 Xtrem™ XC²

STRENGTH LIMIT STATE DESIGN

STEP 4

Step 4 - Verify seismic C1 cracked concrete edge shear resistance - per anchor

Table 4a - Seismic cracked concrete edge resistance, $V_{Rd,c,seis}^0 = \alpha_{seis} V_{Rk,c,seis}^0 / \gamma_{Mc}$ (kN)

Where $\gamma_{Mc} = 1.5$, $\alpha_{seis} = 0.85$, $f'_c = 30$ MPa

Anchor size, d _b	10	12	16	20
Effective depth, h (mm)	90	110	125	170
Edge distance, e _m				
45	3.1	3.4		
50			4.2	
65				6.7

For optimised performance data, please use Ramset iExpert Anchoring Software.

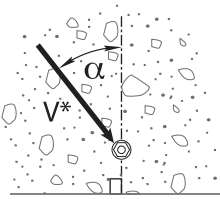

Load direction effect, conc. edge shear, X_{Vd}

Table 4b - Seismic cracked concrete compressive strength effect, shear, X_{Vc}

f' _c (MPa)	20	25	30	40	50
X _{Vc}	0.82	0.90	1	1.16	1.27

Table 4c - Seismic cracked concrete load direction effect, concrete edge shear, X_{Vd}

Angle, α°	0-55	60	70	80	90-180
X _{Vd}	1	1.1	1.2	1.5	2

Table 4d - Seismic cracked concrete anchor spacing and edge distance effect, concrete edge shear, X_{ve}

For single anchor fastening X_{ve}

e/e _m	1.0	1.2	1.4	1.6	1.8	2.0	2.2	2.4	2.6	2.8	3.0	3.2
X _{ve}	1.00	1.31	1.66	2.02	2.41	2.83	3.26	3.72	4.19	4.69	5.20	5.72

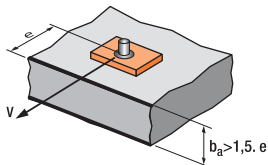

$$X_{ve} = e/e_m * \sqrt{e/e_m}$$

For 2 anchors fastening X_{ve}

e/e _m	1.0	1.2	1.4	1.6	1.8	2.0	2.2	2.4	2.6	2.8	3.0	3.2
a/e _m												
1.0	0.67	0.84	1.03	1.22	1.43	1.65	1.88	2.12	2.36	2.62	2.89	3.16
1.5	0.75	0.93	1.12	1.33	1.54	1.77	2.00	2.25	2.50	2.76	3.03	3.31
2.0	0.83	1.02	1.22	1.43	1.65	1.89	2.12	2.38	2.63	2.90	3.18	3.46
2.5	0.92	1.11	1.32	1.54	1.77	2.00	2.25	2.50	2.77	3.04	3.32	3.61
3.0	1.00	1.20	1.42	1.64	1.88	2.12	2.37	2.63	2.90	3.18	3.46	3.76
3.5		1.30	1.52	1.75	1.99	2.24	2.50	2.76	3.04	3.32	3.61	3.91
4.0			1.62	1.86	2.10	2.36	2.62	2.89	3.17	3.46	3.75	4.05
4.5				1.96	2.21	2.47	2.74	3.02	3.31	3.60	3.90	4.20
5.0					2.33	2.59	2.87	3.15	3.44	3.74	4.04	4.35
5.5						2.71	2.99	3.28	3.71	4.02	4.33	4.65
6.0						2.83	3.11	3.41	3.71	4.02	4.33	4.65

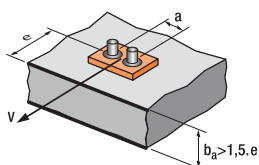

$$X_{ve} = \frac{3*e+a}{6*e_m} * \sqrt{e/e_m}$$

For 3 anchors fastening and more

$$X_{ve} = \frac{3*e + a_1 + a_2 + a_3 + \dots + a_{n-1}}{3*n*e_m} * \sqrt{e/e_m}$$

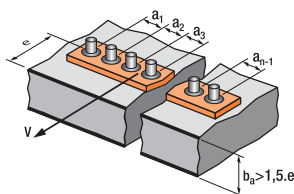

ChemSet™ 801 Xtrem™ XC²

STRENGTH LIMIT STATE DESIGN

Table 4e - Seismic Cracked concrete Pryout failure, $V_{Rd,cp,seis}^0 = \alpha_{seis} V_{Rk,cp,seis} / \gamma_{Mpr}$ (kN)

Where $\gamma_{Mpr} = 1.5$, $\alpha_{seis} = 0.75$, $f'_c = 30$ MPa

Anchor size, d_b	10	12	16	20
Effective depth, h (mm)	90	110	125	170
-40 °C to +40 °C	10.7	28.8	34.6	64.1
-40 °C to +80 °C	10.7	28.8	34.6	64.1

For single anchor values: Multiply $V_{Rd,cp,seis}^0$ *1.13

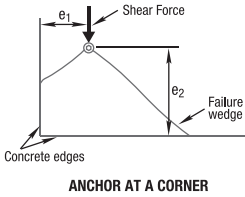

Table 4f Anchor at a corner effect, seismic concrete edge shear, X_{VS}

Note: For $e_1/e_2 > 1.25$, $X_{VS} = 1.0$

Edge distance, e_2 (mm)	25	30	35	50	60	75	125	200	300	400	600	900
Edge distance, e_1 (mm)												
25	0.86	0.77	0.70	0.58	0.53	0.49	0.41	0.37	0.35	0.34	0.32	0.32
30	0.97	0.86	0.78	0.64	0.58	0.52	0.43	0.38	0.36	0.34	0.33	0.32
35	1.00	0.95	0.86	0.69	0.63	0.56	0.46	0.40	0.37	0.35	0.33	0.32
50	1.00	1.00	1.00	0.86	0.77	0.67	0.52	0.44	0.39	0.37	0.35	0.33
60	1.00	1.00	1.00	0.97	0.86	0.75	0.57	0.47	0.41	0.38	0.36	0.34
75	1.00	1.00	1.00	1.00	1.00	0.86	0.64	0.51	0.44	0.41	0.37	0.35
125	1.00	1.00	1.00	1.00	1.00	1.00	0.86	0.65	0.53	0.48	0.42	0.38
200	1.00	1.00	1.00	1.00	1.00	1.00	1.00	0.86	0.67	0.58	0.49	0.42
300	1.00	1.00	1.00	1.00	1.00	1.00	1.00	1.00	0.86	0.72	0.58	0.49
400	1.00	1.00	1.00	1.00	1.00	1.00	1.00	1.00	1.00	0.86	0.67	0.55
500	1.00	1.00	1.00	1.00	1.00	1.00	1.00	1.00	1.00	1.00	0.77	0.61
600	1.00	1.00	1.00	1.00	1.00	1.00	1.00	1.00	1.00	1.00	0.86	0.67
900	1.00	1.00	1.00	1.00	1.00	1.00	1.00	1.00	1.00	1.00	1.00	0.86

Checkpoint 4a

Design seismic cracked concrete edge shear resistance, $V_{Rd,c,seis}$

$$= V_{Rd,c,seis}^0 * X_{vc} * X_{vd} * X_{ve} * X_{vs}$$

Checkpoint 4b

Design seismic cracked concrete Pryout failure,

$$V_{Rd,cp,seis} = V_{Rd,cp,seis}^0 * X_{nc} * X_{ne} * X_{na}$$

STEP 5

Verify seismic C1 cracked concrete shear resistance - per anchor

Table 5a - Seismic Cracked Concrete steel shear resistance, $V_{Rd,s,seis} = \alpha_{seis} V_{Rk,s,seis} / \gamma_{Ms}$ (kN)

where $\alpha_{seis} = 0.85$ and $\gamma_{Ms} = 1.25$

Anchor size, d_b	10	12	16	20
Gr 500 Rebar	10.1	14.5	25.8	40.4

For single anchor values: Multiply $V_{Rd,s,seis}$ *1.17

Checkpoint 5

Design seismic C1 cracked concrete shear resistance, $V_{Rd,seis}$

$$V_{Rd,seis} = \text{minimum of } V_{Rd,c,seis}, V_{Rd,cp,seis}, V_{Rd,s,seis}$$

Check $V^*/V_{Rd,seis} \leq 1$,
if not satisfied return to step 1

ChemSet™ 801 Xtrem™ XC²

STRENGTH LIMIT STATE DESIGN

STEP 6 Combined Loading

Checkpoint 6

Check

$$N^*/N_{Rd,seis} + V^*/V_{Rd,seis} \leq 1.0,$$

if not satisfied return to step 1

Specify

Ramset™ 801 Xtrem™ XC² Injection
(Anchor Size) grade 500 rebar
Drilled Hole Depth to be (h) mm.

Example

Ramset™ 801 Xtrem™ XC² Injection with
20mm grade 500 rebar
Drilled hole depth to be 125mm.
To be installed according to Ramset™
Installation Instructions.

Use Ramset™ iExpert Anchor Software for optimised calculation or where a greater range of anchor layout detail is needed.

SpaTec™ Xtrem™

SEISMIC - MECHANICAL ANCHORS

[Back to index](#)

GENERAL INFORMATION

Performance Related	Material	Installation Related

Product

A high security, high performance, through fixing, torque controlled expansion anchor which has approval for use in cracked and non-cracked concrete.



Compliance

European Technical Assessment (option 1) - ETA-10/0276

Design according to:

- AS5216 (formerly TS101)
- AS1170.4 - Earthquake Actions
- EN1992-4 (formerly ETAG001 Annex C, E & TR045)
- NZS3101 (A3) Section 17 - Seismic Design C1 & C2

Use Ramset™ iExpert Anchor Software for optimised calculation or where a greater range of anchor layout detail is needed.



Benefits, Advantages and Features

- CISMA Report Anchors exposed to seismic actions NTC022
- Highest level of European approval for mechanical expansion anchors
- Approved for all directions (floor, wall, overhead)
- Shallow embedment depths
- Highest performance in cracked concrete
- Zinc Plated to 5µm
- Anchor diameters from M10 to M16

Suitable for structural loads:

- Safety critical loads
- High tensile capacity of Grade 8.8 Steel Bolt.
- Heavy duty, heat treated washer.
- Heavy duty, thick expansion sleeve that provides secure grip to concrete.

Improved security:

- Large expansion reserve that ensures retention in concrete if overloaded.
- Torque induced pull down closes gaps and induces preload.

Resistant to cyclic loading:

- Heavy duty sleeve with integrated pull-down section works to retain 65% of initial preload.

Fast installation:

- Hex Nut & Hex Bolt versions available
- Countersunk heads available.
- Through fixing eliminates marking out and repositioning of fixtures.

Fire rated: Refer Fire rated mechanical anchor section.

Principal Applications

- Seismic Anchoring to Category C1/C2
- Temporary works/propping/bracing Anchoring into cracked & non cracked concrete
- Safety critical loads
- Steel columns & walkways
- Road barrier hold down
- Bridge refurbishment
- Road & Rail tunnel construction
- Wall Plates
- Safety Rails

Installation

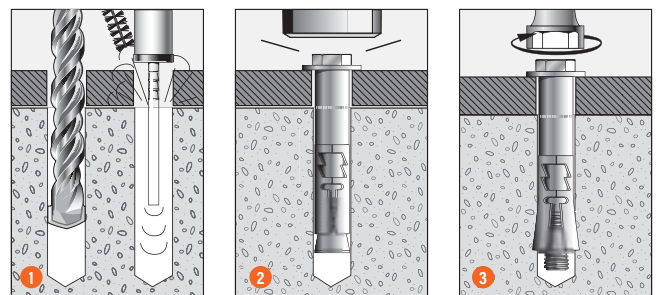

- Drill or core a hole to the recommended diameter and depth using the fixture as a template. Clean the hole thoroughly with a hole cleaning brush. Remove the debris with a hand pump, compressed air, or vacuum.
- After ensuring that the anchor is assembled correctly, insert the anchor through the fixture and drive with a hammer until the washer contacts the fixture.
- Tighten the bolt with a torque wrench to the specified assembly torque.

Seismic Anchors - SpaTec™ Xtrem™

SpaTec Xtrem™

SEISMIC - MECHANICAL ANCHORS

Installation and performance details

Anchor size, d_b (mm)	Drilled hole diameter, d_h (mm)	Fixture hole diameter, d_f (mm)	Anchor effective depth, h (mm)	Depth of drill hole, h_i (mm)	Tightening torque, T_t (Nm)	Concrete substrate thickness, b_m (mm)#	C1-Seismic Cracked Concrete reduced characteristic tensile capacity, $N_{Rd,c,seis}^0$ (kN)*		
							Concrete Compressive Strength, f'_c		
							20 MPa	30 MPa	40 MPa
M10	15	17	70	90	50	140	5.1	6.3	7.2
M12	18	20	80	105	80	160	12.2	15.6	17.3
M16	24	26	100	131	120	200	17.0	21.0	24.2

* Data is based on optimal dimensions, anchor spacing = 3*h, edge distance = 1.5*h

NOTE: For C2 Seismic cracked concrete reduced characteristic tensile capacity:

For M10 Multiply $N_{Rd,c,seis}^0$ * 0.57

For M12 Multiply $N_{Rd,c,seis}^0$ * 0.41

For M16 Multiply $N_{Rd,c,seis}^0$ * 0.52

Note: For performance based on smaller concrete substrate thickness, refer to iExpert Anchor Software or Ramset™ Engineer.

For shear loads acting towards an edge or where optimum dimensions are not achievable, please use the simplified strength limit state design process to verify capacity.

DESCRIPTION AND PART NUMBERS

Anchor size, d_b (mm)	Drilled hole diameter, d_h (mm)	Effective Length, L_e (mm)	Fixture thickness, t (mm)	ETA Designation Number	Part Number
					Zinc (Hex Hd)
M10	15	90	20	V10-15/20	SP10105
M12	18	90	10	V12-18/10	SP12105
		105	25	V12-18/25	SP12120
M16	24	125	25	V16-24/25	SP16145

ENGINEERING PROPERTIES

Description	Material	Protection
Cone	1.0765 steel EN 10 087	Galvanised 5µm
Expansion Sleeve	1.5330 steel EN 10 149-2	Galvanised 5µm
Distance sleeve	TS37 a BK or S300Pb NF A 49 341	Galvanised 5µm
Threaded rod	1. Steel Grade 8.8 EN 20 898-1	Galvanised 5µm
Screw	1. Steel Grade 8.8 EN 20 898-1	Galvanised 5µm
Washer	HLE S550MC	Galvanised 5µm
Hexagonal Nut	Grade 8 EN 20 898-2	Galvanised 5µm

SpaTec™ Xtrem™

STRENGTH LIMIT STATE DESIGN

STEP 1

Select anchor to be evaluated

Table 1a - Indicative combined loading - interaction diagram

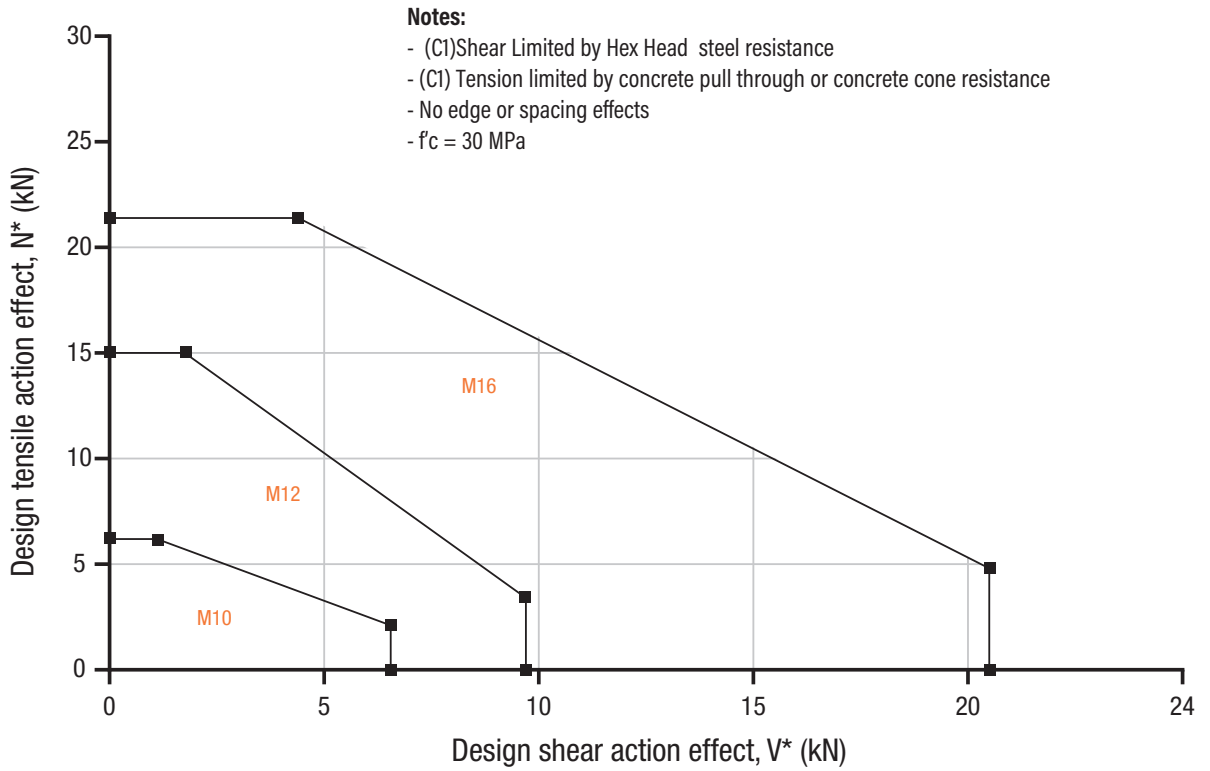

Table 1b Absolute minimum edge distance and anchor spacing values, e_m and a_m (mm)

Anchor size, d_b	M10	M12	M16
Effective depth, h (mm)	70	80	100
Min. Anchor spacing - a_m	70	80	100
For - e_m	100	160	180
Min. Edge Distance - e_m	70	80	100
For - a_m	160	200	220

Step 1c Calculate anchor effective depth, h (mm)

Refer to "Description and Part Numbers" table in the SARB ANZ on the previous page.

Effective depth, h (mm)

$$h = L_e - t$$

t = total thickness of material(s) being fixed

Checkpoint 1

Anchor size determined, absolute minimum compliance achieved, effective depth (h) calculated.

SpaTec Xtrem™

STRENGTH LIMIT STATE DESIGN

Seismic Anchors - SpaTec Xtrem™

STEP 2

Verify Seismic C1 or C2 cracked concrete cone tensile resistance - per anchor

Table 2a - Seismic Cracked concrete cone resistance, $N_{Rk,c,seis} = \alpha_{seis} N_{Rk,c,seis}^0 / \gamma_{Msp}$ (kN) $\gamma_{Msp} = 1.5$, $f'_c = 30$ MPa, $\alpha_{seis} = 0.75$ where $N_{Rk,c}^0 = k_1 * \sqrt{f'_c} * h_{ef}^{1.5}$

Anchor size, d_b	M10	M12	M16
Drill hole dia, d_h (mm)	15	18	24
Effective depth, h (mm)			
70	12.3		
80		15.0	
100			21.0

For single anchor values: Multiply $N_{Rk,c,seis}$ * 1.13
 For optimised performance data, please use Ramset iExpert Anchoring Software.

Table 2b - Seismic cracked concrete compressive strength effect, tension, X_{nc}

f'_c (MPa)	20	30	40	50
X_{nc}	0.81	1.00	1.15	1.27

Table 2c - Seismic Cracked concrete Edge distance effect, tension, X_{ne}

Anchor size, d_b	M10	M12	M16
Edge distance, e (mm)			
70	0.75		
80	0.82	0.75	
90	0.89	0.81	
100	0.96	0.88	0.75
120	1	1	0.85
150			1

Table 2d - Seismic cracked concrete anchor spacing effect, tension, X_{na}

Anchor size, d_b	M10	M12	M16
Anchor spacing, a (mm)			
70	0.67		
80	0.69	0.67	
100	0.74	0.71	0.67
125	0.80	0.76	0.71
150	0.86	0.81	0.75
180	0.93	0.88	0.80
210	1	0.94	0.85
240		1	0.90
300			1

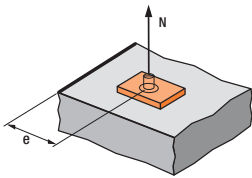

$$X_{ne} = 0.25 + 0.5 * (e/h)$$

Where $e_m \leq e \leq e_c$

$$e_c = 1.5 * h$$

Note: Tabled values are based on the nominal effective depth, h shown in the installation details.
 For other values of X_{ne} , please use equation shown above.

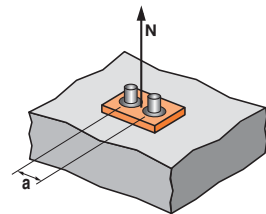

$$X_{na} = 0.5 + a / (6 * h)$$

Where $a_m \leq a \leq a_c$

$$a_c = 3 * h$$

Note: Tabled values are based on the nominal effective depth, h shown in the installation details.
 For other values X_{na} , please use equation shown above.

Checkpoint 2

Design Seismic cracked concrete cone resistance, $N_{Rd,c,seis}$

$$N_{Rd,c,seis} = N_{Rk,c,seis} * X_{nc} * X_{ne} * X_{na}$$

SpaTec Xtrem™

STRENGTH LIMIT STATE DESIGN

STEP 3

Verify seismic C1 or C2 cracked concrete tensile resistance tension - per anchor

Table 3a - Seismic (C1 & C2) Cracked Concrete steel resistance, tensile, $N_{Rd,s,seis} = \alpha_{seis} N_{Rk,s,seis} / \gamma_{Ms}$ (kN) where $\alpha_{seis} = 1.0$, $\gamma_{Ms} = 1.5$

Anchor size, d_b	M10	M12	M16
Carbon Steel	30.7	44.7	84.0

Table 3b-1 - Seismic (C1) Cracked concrete Pull-out resistance**, $N_{Rd,p,seis}^0 = \alpha_{seis} N_{Rk,p,seis}^0 / \gamma_{Msp}$ (kN)
 $\gamma_{Msp} = 1.5, \alpha_{seis} = 0.85, f'c = 30$ MPa

Anchor size, d_b	M10	M12	M16
Drill hole dia, d_h (mm)	15	18	24
Effective depth, h (mm)			
70	6.3		
80		17.8	
100			24.8

**Cracked concrete Pull-out resistance is not influenced by reduced anchor spacing or edge distance.
 For single anchor multiply $N_{Rd,p,seis}^0$ *1.17

Table 3b-2 - Seismic (C2) Cracked concrete Pull-out resistance**, $N_{Rd,p,seis}^0 = \alpha_{seis} N_{Rk,p,seis}^0 / \gamma_{Msp}$ (kN)
 $\gamma_{Msp} = 1.5, \alpha_{seis} = 0.85, f'c = 30$ MPa

Anchor size, d_b	M10	M12	M16
Drill hole dia, d_h (mm)	15	18	24
Effective depth, h (mm)			
70	3.6		
80		6.4	
100			11.4

** Cracked concrete Pull-out resistance is not influenced by reduced anchor spacing or edge distance.
 For single anchor multiply $N_{Rd,p,seis}^0$ *1.17

Checkpoint 3a

Design Seismic C1 or C2 cracked concrete pull out resistance, $N_{Rd,p,seis}$
 $N_{Rd,p,seis} = N_{Rd,p,seis}^0 * X_{nc}$

Checkpoint 3b

Design Seismic C1 or C2 cracked concrete tensile resistance, $N_{Rd,seis}$
 $N_{Rd,seis} = \text{Minimum of } N_{Rd,c,seis}, N_{Rd,p,seis}, N_{Rd,s,seis}$
 Check $N^*/N_{Rd,seis} \leq 1$
 if not satisfied return to step 1

SpaTec Xtrem™

STRENGTH LIMIT STATE DESIGN

Seismic Anchors - SpaTec Xtrem™

STEP 4

Verify Seismic C1 or C2 cracked concrete edge shear resistance - per anchor

Table 4a - Seismic cracked concrete edge resistance, shear,

$$V_{Rd,c,seis}^0 = \alpha_{seis} V_{Rk,c} / \gamma_{Mc} \text{ (kN)}, \gamma_{Mc} = 1.5, \alpha_{seis} = 0.85, f'_c = 30 \text{ MPa}$$

Anchor size, d _b	M10	M12	M16
min. edge distance, e _m	70	80	100
min. anchor spacing, a _m	160	200	220
Effective depth, h (mm)			
70	2.2		
80		3.0	
100			4.5

Note: Data includes annular gap reduction factor of 0.5

For single anchor values: Multiply V_{Rd,c,seis}⁰ *1.17

For optimised performance data, please use Ramset iExpert Anchoring Software.

Table 4b - Seismic cracked concrete compressive strength effect, shear, X_{vc}

f' _c (MPa)	20	25	30	40	50
X _{vc}	0.82	0.91	1	1.15	1.29

Table 4c - Seismic cracked concrete load direction effect, concrete edge shear, X_{vd}

Angle, α°	0-55	60	70	80	90-180
X _{vd}	1	1.1	1.2	1.5	2

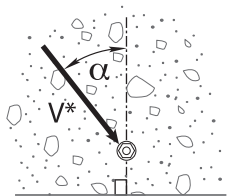

Load direction effect, conc. edge shear, X_{vd}

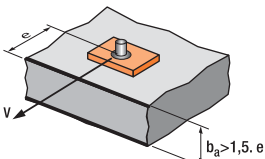

$$X_{ve} = e/e_m * \sqrt{e/e_m}$$

Table 4d - Seismic cracked concrete anchor spacing and edge distance effect, concrete edge shear, X_{ve}

For single anchor fastening X_{ve}

e/e _m	1.0	1.2	1.4	1.6	1.8	2.0	2.2	2.4	2.6	2.8	3.0	3.2
X _{ve}	1.00	1.31	1.66	2.02	2.41	2.83	3.26	3.72	4.19	4.69	5.20	5.72

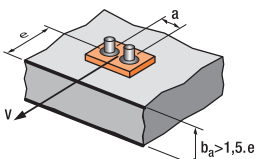

$$X_{ve} = \frac{3 * e + a}{6 * e_m} * \sqrt{e/e_m}$$

For 2 anchors fastening X_{ve}

e/e _m	1.0	1.2	1.4	1.6	1.8	2.0	2.2	2.4	2.6	2.8	3.0	3.2
a/e _m												
1.0	0.67	0.84	1.03	1.22	1.43	1.65	1.88	2.12	2.36	2.62	2.89	3.16
1.5	0.75	0.93	1.12	1.33	1.54	1.77	2.00	2.25	2.50	2.76	3.03	3.31
2.0	0.83	1.02	1.22	1.43	1.65	1.89	2.12	2.38	2.63	2.90	3.18	3.46
2.5	0.92	1.11	1.32	1.54	1.77	2.00	2.25	2.50	2.77	3.04	3.32	3.61
3.0	1.00	1.20	1.42	1.64	1.88	2.12	2.37	2.63	2.90	3.18	3.46	3.76
3.5		1.30	1.52	1.75	1.99	2.24	2.50	2.76	3.04	3.32	3.61	3.91
4.0			1.62	1.86	2.10	2.36	2.62	2.89	3.17	3.46	3.75	4.05
4.5				1.96	2.21	2.47	2.74	3.02	3.31	3.60	3.90	4.20
5.0					2.33	2.59	2.87	3.15	3.44	3.74	4.04	4.35
5.5						2.71	2.99	3.28	3.57	3.87	4.17	4.48
6.0						2.83	3.11	3.41	3.71	4.02	4.33	4.65

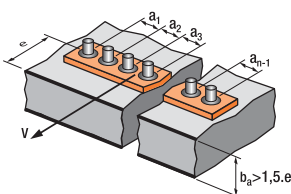

For 3 anchors fastening and more X_{ve}

$$X_{ve} = \frac{3 * e + a_1 + a_2 + a_3 + \dots + a_{n-1}}{3 * n * e_m} * \sqrt{e/e_m}$$

SpaTec Xtrem™

STRENGTH LIMIT STATE DESIGN

Seismic Anchors - SpaTec Xtrem™

Table 4e - Seismic Cracked concrete Pryout failure, $V_{Rd,cp,seis}^0 = \alpha_{seis} V_{Rk,cp,seis} / \gamma_{Mpr}$ (kN)

Where $\gamma_{Mpr} = 1.5$, $\alpha_{seis} = 0.75$, $f'_c = 30$ MPa

Anchor size, d_b	M10	M12	M16
Effective depth, h (mm)			
70	12.4		
80		15.1	
100			21.1

Note: Data includes annular gap reduction factor of 0.5

For single anchor values: Multiply $V_{Rd,c,seis}^0$ *1.13

Table 4f Anchor at a corner effect, concrete edge shear, X_{vs}

Note: For $e_1/e_2 > 1.25$, $X_{vs} = 1.0$

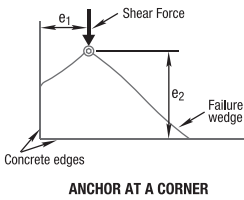

Edge distance, e_2 (mm)	25	30	35	50	60	75	125	200	300	400	600	900
Edge distance, e_1 (mm)												
25	0.86	0.77	0.70	0.58	0.53	0.49	0.41	0.37	0.35	0.34	0.32	0.32
30	0.97	0.86	0.78	0.64	0.58	0.52	0.43	0.38	0.36	0.34	0.33	0.32
35	1.00	0.95	0.86	0.69	0.63	0.56	0.46	0.40	0.37	0.35	0.33	0.32
50	1.00	1.00	1.00	0.86	0.77	0.67	0.52	0.44	0.39	0.37	0.35	0.33
60	1.00	1.00	1.00	0.97	0.86	0.75	0.57	0.47	0.41	0.38	0.36	0.34
75	1.00	1.00	1.00	1.00	1.00	0.86	0.64	0.51	0.44	0.41	0.37	0.35
125	1.00	1.00	1.00	1.00	1.00	1.00	0.86	0.65	0.53	0.48	0.42	0.38
200	1.00	1.00	1.00	1.00	1.00	1.00	1.00	0.86	0.67	0.58	0.49	0.42
300	1.00	1.00	1.00	1.00	1.00	1.00	1.00	1.00	0.86	0.72	0.58	0.49
400	1.00	1.00	1.00	1.00	1.00	1.00	1.00	1.00	1.00	0.86	0.67	0.55
500	1.00	1.00	1.00	1.00	1.00	1.00	1.00	1.00	1.00	1.00	0.77	0.61
600	1.00	1.00	1.00	1.00	1.00	1.00	1.00	1.00	1.00	1.00	0.86	0.67
900	1.00	1.00	1.00	1.00	1.00	1.00	1.00	1.00	1.00	1.00	1.00	0.86

Checkpoint 4a

Design seismic cracked concrete edge shear resistance, $V_{Rd,c,seis}$

$$V_{Rd,c,seis} = V_{Rk,c,seis}^0 * X_{vc} * X_{vd} * X_{ve} * X_{vs}$$

Checkpoint 4b

Design seismic cracked concrete Pryout failure, $V_{Rd,cp,seis}$

$$V_{Rd,cp,seis} = V_{Rk,cp,seis}^0 * X_{nc} * X_{ne} * X_{na}$$

STEP 5

Verify seismic C1 or C2 cracked concrete shear resistance - per anchor

Table 5a-1 - Seismic (C1) Cracked Concrete steel shear resistance, $V_{Rk,s,seis} = \alpha_{seis} V_{Rk,s,seis} / \gamma_{Ms}$ (kN)

where $\alpha_{seis} = 0.85$, $\gamma_{Ms} = 1.25$

Anchor size, d_b	M10	M12	M16
Carbon Steel	5.8	9.7	20.6

Note: Data includes annular gap reduction factor of 0.5. For single anchor multiply $V_{Rd,s,seis}$ *1.17

Table 5a-2 - Seismic (C2) Cracked Concrete steel shear resistance, $V_{Rk,s,seis} = \alpha_{seis} V_{Rk,s,seis} / \gamma_{Ms}$ (kN)

where $\alpha_{seis} = 0.85$, $\gamma_{Ms} = 1.25$

Anchor size, d_b	M10	M12	M16
Carbon Steel	4.9	9.7	19.8

Note: Data includes annular gap reduction factor of 0.5. For single anchor multiply $V_{Rd,s,seis}$ *1.17

Checkpoint 5

Design Seismic C1 or C2 cracked concrete shear resistance, $V_{Rd,seis}$

$$V_{Rd,seis} = \text{Minimum of } V_{Rd,c,seis}, V_{Rd,cp,seis}, V_{Rd,s,seis}$$

Check $V^*/V_{Rd,seis} \leq 1$

if not satisfied return to step 1

SpaTec™ Xtrem™

STRENGTH LIMIT STATE DESIGN

STEP 6 Combined loading and specification

Checkpoint 6

Check
 $N^*/N_{Rd,seis} + V^*/V_{Rd,seis} \leq 1.0$
if not satisfied return to step 1

Specify
Ramset™ SpaTec™ Xtrem™ Anchor,
(Anchor Size) (Part Number)
Maximum fixed thickness to be (t) mm.

Example
Ramset™ SpaTec™ Xtrem™ Anchor, M12 (SP12120).
Maximum fixed thickness to be 8 mm. To be installed in
accordance with Ramset Installation Instructions.

Ramset™ iExpert Anchor Software for optimised calculation or where a greater range of anchor layout detail is needed.

TruBolt™ Xtrem™

SEISMIC - MECHANICAL ANCHORS

[Back to index](#)

GENERAL INFORMATION

Performance Related	Material Specification	Installation Related

Product

A seismic certified heavy duty, torque controlled expansion anchor for permanent anchoring into concrete. Certified for seismic C1 & C2 applications.



Compliance

European Technical Assessment (option 1) - ETA-21/0973

Design according to:

- AS5216 (formerly TS101)
- AS1170.4 - Earthquake Actions
- EN1992-4 (formerly ETAG001 Annex C, E & TR045)
- NZS3101 (A3) Section 17 - Seismic Design C1 & C2



Use Ramset™ iExpert Anchor Software for optimised calculation or where a greater range of anchor layout detail is needed.

Benefits, Advantages and Features

- Highest level of European approval for mechanical expansion anchors
- Approved for all directions (floor, wall, overhead)
- Maximum Tensile & Shear capacities in cracked concrete
- Zinc Plating 5µm and Stainless Steel A4 316
- Anchor diameters M10 to M20

Suitable for structural loads:

- "True to size" through fixture anchor

Improved security:

- Torque induced pull down closes gaps and induces preload.

Resistant to cyclic loading:

- Heavy duty sleeve with pull-down of fixture
- Anti rotation expansion sleeve

Fast installation:

- Anchor diameter equals hole diameter
- Shallow embedment depths
- Through fixing eliminates marking out and repositioning of fixtures.

Principal Applications

- Seismic anchoring to Category C1/C2
- Anchoring into cracked & non cracked concrete
- Structural Steel columns & beams
- Road barrier hold down
- Bridge refurbishment
- Road & Rail tunnel construction
- Wall Plates
- Safety barriers
- Stadium seating
- Pallet racking
- Shallow embedment depths from 50mm
- Intended working life of the anchor of 50 years

Installation

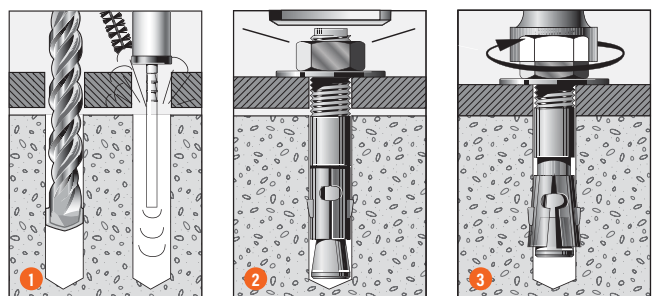

- Drill hole to correct diameter and depth. Important: Use Ramset™ Dustless Drilling System to ensure holes are clean. Alternatively, clean thoroughly with brush and remove debris by way of vacuum or hand pump, compressed air etc.
- Insert the TruBolt™ Xtrem™ through the fixture and drive with a hammer until washer contacts the fixture.
- Tighten the TruBolt™ Xtrem™ nut with a torque wrench to specified assembly torque.

Seismic Anchors - TruBolt™ Xtrem™

TruBolt™ Xtrem™

SEISMIC - MECHANICAL ANCHORS

Installation and performance details

Anchor size, d _b (mm)	Drilled hole diameter, d _h (mm)	Fixture hole diameter, d _f (mm)	Anchor effective depth, h _{ef} (mm)	Depth of drill hole, h _i (mm)	Tightening torque, T _r (Nm)	Concrete substrate thickness, b _m (mm) #	C1-Seismic Cracked Concrete reduced characteristic tensile capacity, N _{rd,p,seis} (kN) *					
							Concrete Compressive Strength, f _c					
							20 MPa		30 MPa		40 MPa	
							C1	C2***	C1	C2***	C1	C2***
M10	10	12	60	75	45	120	4.1	1.5	4.5	1.7	4.8	1.8
M12	12	14	70	90	60**	140	9.0	3.3	9.7	3.6	10.3	3.8
M16	16	18	85	110	110	170	11.3	10.1	13.0	11.7	14.3	12.9
M20	20	22	100	130	160	200	16.9	14.4	20.7	17.6	23.9	20.3

Note: M20 not available in SS

*Data is based on optimal dimensions, anchor spacing = 3*h, edge distance = 1.5*h

** Tightening Torque, T_r taken as 75 Nm for stainless steel M12 TruBolt Xtrem

***For C2 Seismic cracked concrete for stainless steel TruBolt Xtrem variant reduced characteristic tensile capacity:

For M10 SS Multiply N_{rd,p,seis} * 0.88

For M12 SS Multiply N_{rd,p,seis} * 1.0

For M16 SS Multiply N_{rd,p,seis} * 0.81

Note: For performance based on smaller concrete substrate thickness, refer to iExpert Anchor Software or Ramset™ Engineer.

For shear loads acting towards an edge or where optimum dimensions are not achievable, please use the simplified strength limit state design process to verify capacity

DESCRIPTION AND PART NUMBERS

Anchor size, d _b (mm)	Drilled hole diameter, d _h (mm)	Effective Length, L _e (mm)	Maximum Fixture Thickness, t _{fix,max} (mm)	ETA Designation Number		Part Number	
						Zn	S/S
M10	10	65	5	10x85/25-5	D	T10085X	-
		75	15	10x95/35-15	2	-	T10095SSX
		80	20	10x100/40-20	F	T10100X	-
		85	25	10x105/45-25	3	-	T10105SSX
		100	40	10x120/60-40	G	T10120X	-
		110	50	10x130/70-50	4	-	T10130SSX
M12	12	80	10	12x105/30-10	F	T12105X	-
		85	15	12x110/35-15	2	-	T12110SSX
		90	20	12x115/40-20	G	T12115X	-
		95	25	12x120/45-25	3	-	T12120SSX
		110	40	12x135/60-40	I	T12135X	-
		115	45	12x140/65-45	4	-	T12140SSX
M16	16	105	20	16x140/40-20	2	-	T16140SSX
		110	25	16x145/45-25	I	T16145X	-
		135	50	16x170/70-50	K	T16170X	-
M20	20	130	30	20x170/30	K	T20170X	-
		160	60	20x200/60	M	T20200X	-

ENGINEERING PROPERTIES

Description	Zn		S/S	
	Material	Protection	Material	Protection
Bolt	Carbon Steel	M10 - M20: Zinc electroplated (>5µm) EN ISO 4042:2018	M10-M16 Stainless Steel A4	M10-M16 Stainless Steel A4, EN 10088.3:2014 + ,coated
Clip	M10 - M20 Carbon Steel	M10 - M20: Zinc electroplated (>5µm) EN ISO 4042:2018	M10-M16 Stainless Steel A4	M10-M16 Stainless Steel A4, EN 10088.3:2014
Washer	M10 - M20 EN ISO 7092:200	M10 - M20: Zinc electroplated (>5µm) EN ISO 4042:2018	M10 - M16 EN ISO 7092:200	M10-M16 Stainless Steel A4
Nut	Steel, Strength class 8, ISO 898-2:2012	M10: Zinc electroplated (>5µm) EN ISO 4042:2018	M10-M16 Stainless Steel A4-80	M10-M16 Stainless Steel A4-80, EN ISO 3506-2:2019, coated
		M12 - M20: Zinc electroplated (>5µm) EN ISO 4042:2018		

TruBolt™ Xtrem™

STRENGTH LIMIT STATE DESIGN

STEP 1

Select anchor to be evaluated

Table 1a Indicative combined loading - interaction diagram

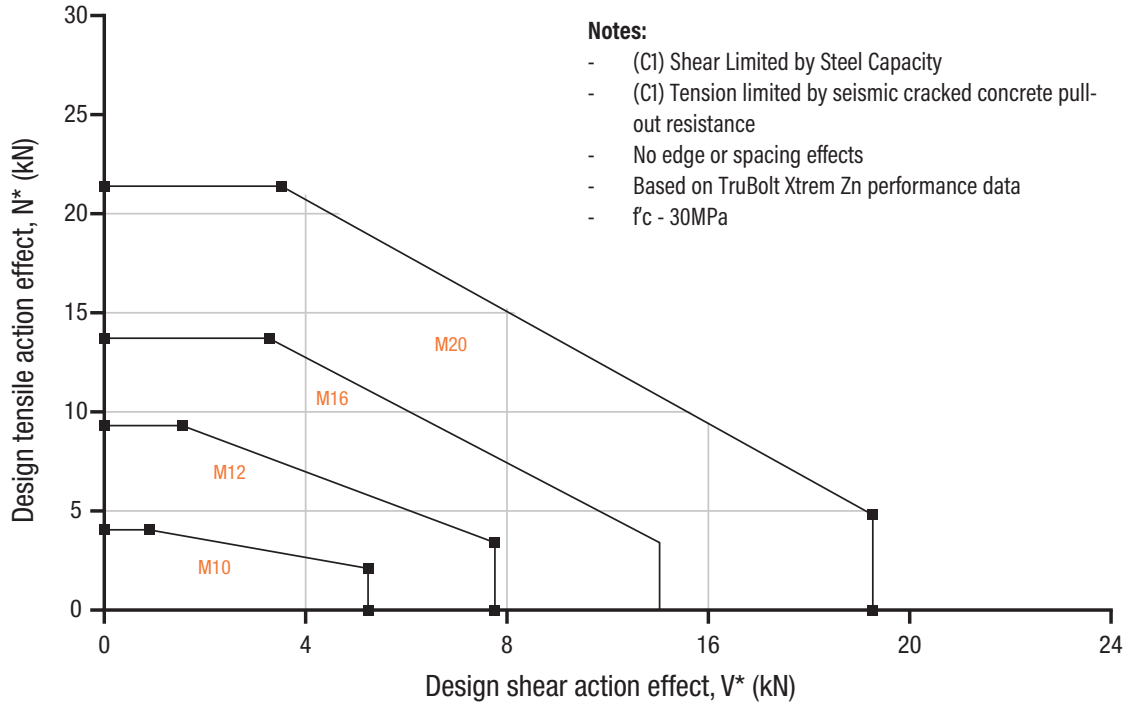

Table 1b Absolute minimum edge distance and anchor spacing values, e_m and a_m (mm)

Anchor size, d_b	M10	M12	M16	M20
Effective depth, h (mm)	60	70	85	100
Min. member thickness (mm)*	120	140	170	200
Min. Anchor spacing - a_m	55	60	90	100
For - e_m	70**	100	100	120
Min. Edge Distance - e_m	55	60	80	100
For - a_m	90	145	110	130

*Note: For calculations based on smaller member thickness, refer to iExpert Anchor Software or Ramset™ Engineer

** for Trubolt Xtreme SS - $e_m = 65$

Step 1c Calculate anchor effective depth, h (mm)

Refer to "Description and Part Numbers" table in the SARB ANZ on previous page.

Effective depth, h (mm)

$$h = L_e - t$$

t = total thickness of material(s) being fixed

Checkpoint 1

Anchor size determined, absolute minima compliance achieved, effective depth (h) calculated.

TruBolt™ Xtrem™

STRENGTH LIMIT STATE DESIGN

Seismic Anchors - TruBolt™ Xtrem™

STEP 2

Verify seismic cracked concrete cone tensile resistance - per anchor

Table 2a - Seismic Cracked concrete cone resistance, $N_{Rk,c,seis} = \alpha_{seis} N_{Rk,c,seis}^0 / \gamma_{Msp}$ (kN) $\gamma_{Msp} = 1.5$, $f'_c = 30$ MPa, $\alpha_{seis} = 0.75$ where $N_{Rk,c}^0 = k_1 * \sqrt{f'_c} * h_{ef}^{1.5}$

Anchor size, d_b	M10	M12	M16	M20
Drill hole dia, d_h (mm)	10	12	16	20
Effective depth, h (mm)				
60	9.8			
70		12.3		
85			16.5	
100				21.0

For single anchor values: Multiply $N_{Rk,c,seis}$ *1.13

For optimised performance data, please use Ramset iExpert Anchoring Software.

Table 2b - Seismic cracked concrete compressive strength effect, tension, X_{nc} and Pull-out, X_{npc}

Anchor size, d_b	Tension X_{nc}	M10	M12	M16	M20
		Pull-out X_{npc}			
f'_c (MPa)					
20	0.81	0.93	0.93	0.87	0.82
25	0.91	0.97	0.97	0.94	0.92
30	1.00	1.00	1.00	1.00	1.00
40	1.15	1.06	1.06	1.10	1.16
50	1.29	1.11	1.11	1.20	1.30

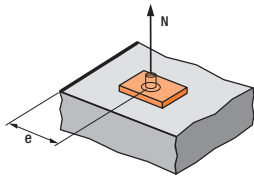

$$X_{ne} = 0.25 + 0.5 * (e/h)$$

Where $e_m \leq e \leq e_c$

$$e_c = 1.5 * h$$

Note: Tabled values are based on the nominal effective depth, h shown in the installation details. For other values of X_{ne} , please use equation shown above.

Table 2c - Seismic cracked concrete Edge distance effect, tension, X_{ne}

Anchor Size, d_b	10	12	16	20
Edge distance, e (mm)				
55	0.70			
60	0.75	0.67		
70	0.83	0.75		
80	0.91	0.82	0.72	
90	1	0.89	0.77	
100		0.96	0.83	0.75
110		1	0.89	0.80
120			0.95	0.85
130			1	0.90
150				1

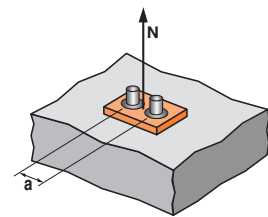

$$X_{na} = 0.5 + a / (6 * h)$$

Where $a_m \leq a \leq a_c$

$$a_c = 3 * h$$

Note: Tabled values are based on the nominal effective depth, h shown in the installation details. For other values of X_{na} , please use equation shown above.

Table 2d - Seismic cracked concrete anchor spacing effect, tension, X_{na}

Anchor Size, d_b	10	12	16	20
Anchor spacing, a (mm)				
55	0.65			
60	0.66	0.64		
70	0.69	0.66		
80	0.72	0.69		
90	0.75	0.71	0.67	
100	0.77	0.73	0.69	0.66
125	0.84	0.79	0.74	0.70
150	0.91	0.85	0.79	0.75
180	1.00	0.92	0.85	0.80
210		1.00	0.91	0.85
255			1.00	0.92
300				1.00

Checkpoint 2

Design cracked concrete cone resistance, $N_{Rd,c,seis}$

$$N_{Rd,c,seis} = N_{Rk,c,seis} * X_{nc} * X_{ne} * X_{na}$$

TruBolt™ Xtrem™

STRENGTH LIMIT STATE DESIGN

STEP 3

Verify cracked concrete tensile resistance tension - per anchor

Table 3a - Seismic (C1 & C2) Cracked Concrete steel resistance, tensile, $N_{Rk,s,seis} = \alpha_{seis} N_{Rk,s,seis} / \gamma_{Ms}$ (kN)
 where $\alpha_{seis} = 1.0$

Anchor size, d_b	M10	M12	M16	M20
Carbon Steel	19.5	25.5	43.1	66.1
Stainless Steel	20.5	29.7	43.2	-

Carbon Steel: $\gamma_{Ms} = 1.5$
 Stainless Steel: $\gamma_{Ms} = 1.76$ (M10-M12)
 $\gamma_{Ms} = 2.11$ (M16)

Table 3b-1 - Seismic (C1) Cracked concrete Pull-out resistance, $N_{Rd,p,seis}^0 = \alpha_{seis} N_{Rk,p,seis}^0 / \gamma_{Msp}$ (kN)**
 $\gamma_{Msp} = 1.5, \alpha_{seis} = 0.85, f'c = 30$ MPa

Anchor size, d_b	M10	M12	M16	M20*
Drill hole dia, d_h (mm)	10	18	24	20
Effective depth, h (mm)				
60	4.5			
70		9.7		
80			13.0	
100				20.7

**Cracked concrete Pull-out resistance is not influenced by reduced anchor spacing or edge distance.

For single anchor multiply $N_{Rd,p,seis}^0 * 1.17$

Table 3b-2 - Seismic (C2) Cracked concrete Pull-out resistance, $N_{Rd,p,seis}^0 = \alpha_{seis} N_{Rk,p,seis}^0 / \gamma_{Msp}$ (kN)**
 $\gamma_{Msp} = 1.5, \alpha_{seis} = 0.85, f'c = 30$ MPa

Anchor size, d_b	M10	M12	M16	M20
Drill hole dia, d_h (mm)	10	18	24	20
Effective depth, h (mm)				
60	1.7			
70		3.6		
80			11.7	
100				17.6

** Cracked concrete Pull-out resistance is not influenced by reduced anchor spacing or edge distance.

For single anchor multiply $N_{Rd,p,seis}^0 * 1.17$

For M10 SS Multiply $N_{Rd,p,seis}^0 * 0.88$

For M12 SS Multiply $N_{Rd,p,seis}^0 * 1.0$

For M16 SS Multiply $N_{Rd,p,seis}^0 * 0.81$

Checkpoint 3a

Design Seismic cracked concrete pull-out resistance, $N_{Rd,p,seis}$

$$N_{Rd,p,seis} = N_{Rd,p,seis}^0 * X_{npc}$$

Checkpoint 3b

Design Seismic cracked concrete tensile resistance, $N_{Rd,seis}$

$$N_{Rd,seis} = \text{Minimum of } N_{Rd,c,seis}, N_{Rd,p,seis}, N_{Rd,s,seis}$$

Check $N^*/N_{Rd,seis} \leq 1$

if not satisfied return to step 1

TruBolt™ Xtrem™

STRENGTH LIMIT STATE DESIGN

Seismic Anchors - TruBolt™ Xtrem™

STEP 4

Verify cracked concrete edge shear resistance - per anchor

Table 4a - Seismic cracked concrete edge resistance, $V_{Rd,c,seis}^0 = \alpha_{seis} * V_{Rk,c,seis}^0 / \gamma_{Mc}$ (kN)

$\gamma_{Mc} = 1.5, \alpha_{seis} = 0.85, f'_c = 30 \text{ MPa}$

Anchor size, d_b	M10	M12	M16	M20
Effective depth, h (mm)	60	70	85	100
Edge distance, e_m				
55	1.8			
60		2.2		
80			3.5	
100				5.0

Note: Data includes annular gap reduction factor of 0.5

For single anchor values: Multiply $V_{Rd,c,seis}^0$ *1.17

For optimised performance data, please use Ramset iExpert Anchoring Software.

Table 4b - Seismic cracked concrete compressive strength effect, shear, X_{vc}

f'_c (MPa)	20	25	30	40	50
X_{vc}	0.82	0.91	1	1.15	1.29

Table 4c - Seismic cracked concrete load direction effect, concrete edge shear, X_{vd}

Angle, α°	0-55	60	70	80	90-180
X_{vd}	1	1.1	1.2	1.5	2

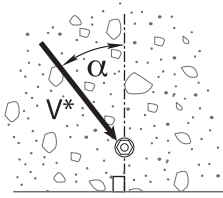

Load direction effect, conc. edge shear, X_{vd}

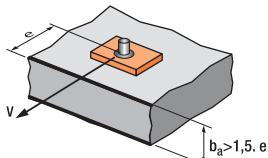

$$X_{ve} = e/e_m * \sqrt{e/e_m}$$

Table 4d - Seismic cracked concrete anchor spacing and edge distance effect, concrete edge shear, X_{ve}

For single anchor fastening X_{ve}

e/e_m	1.0	1.2	1.4	1.6	1.8	2.0	2.2	2.4	2.6	2.8	3.0	3.2
X_{ve}	1.00	1.31	1.66	2.02	2.41	2.83	3.26	3.72	4.19	4.69	5.20	5.72

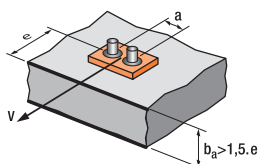

$$X_{ve} = \frac{3*e+a}{6*e_m} * \sqrt{e/e_m}$$

For 2 anchors fastening X_{ve}

e/e_m	1.0	1.2	1.4	1.6	1.8	2.0	2.2	2.4	2.6	2.8	3.0	3.2
a/e_m												
1.0	0.67	0.84	1.03	1.22	1.43	1.65	1.88	2.12	2.36	2.62	2.89	3.16
1.5	0.75	0.93	1.12	1.33	1.54	1.77	2.00	2.25	2.50	2.76	3.03	3.31
2.0	0.83	1.02	1.22	1.43	1.65	1.89	2.12	2.38	2.63	2.90	3.18	3.46
2.5	0.92	1.11	1.32	1.54	1.77	2.00	2.25	2.50	2.77	3.04	3.32	3.61
3.0	1.00	1.20	1.42	1.64	1.88	2.12	2.37	2.63	2.90	3.18	3.46	3.76
3.5		1.30	1.52	1.75	1.99	2.24	2.50	2.76	3.04	3.32	3.61	3.91
4.0			1.62	1.86	2.10	2.36	2.62	2.89	3.17	3.46	3.75	4.05
4.5				1.96	2.21	2.47	2.74	3.02	3.31	3.60	3.90	4.20
5.0					2.33	2.59	2.87	3.15	3.44	3.74	4.04	4.35
5.5						2.71	2.99	3.28	3.71	4.02	4.33	4.65
6.0						2.83	3.11	3.41	3.71	4.02	4.33	4.65

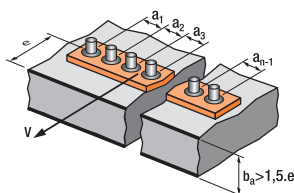

For 3 anchors fastening and more X_{ve}

$$X_{ve} = \frac{3*e + a_1 + a_2 + a_3 + \dots + a_{n-1}}{3*n*e_m} * \sqrt{e/e_m}$$

TruBolt™ Xtrem™

STRENGTH LIMIT STATE DESIGN

Seismic Anchors - TruBolt™ Xtrem™

Table 4e - Seismic Cracked concrete Pryout failure, $V_{Rd,cp,seis}^o = \alpha_{seis} V_{Rk,cp,seis} / \gamma_{Mpr}$ (kN)

$\gamma_{Mpr} = 1.5, \alpha_{seis} = 0.75, f'_c = 30 \text{ MPa}$

Anchor size, d_b	M10	M12	M16	M20
Effective depth, h (mm)				
60	9.8			
70		12.4		
85			16.5	
100				21.1

Note: Data includes annular gap reduction factor of 0.5

For single anchor values: Multiply $V_{Rd,c,seis}^o$ *1.13

Table 4f Anchor at a corner effect, concrete edge shear, X_{VS}

Note: For $e_1/e_2 > 1.25, X_{VS} = 1.0$

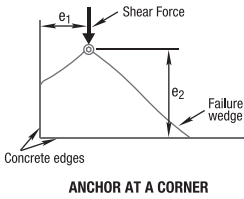

Edge distance, e_2 (mm)	25	30	35	50	60	75	125	200	300	400	600	900
Edge distance, e_1 (mm)												
25	0.86	0.77	0.70	0.58	0.53	0.49	0.41	0.37	0.35	0.34	0.32	0.32
30	0.97	0.86	0.78	0.64	0.58	0.52	0.43	0.38	0.36	0.34	0.33	0.32
35	1.00	0.95	0.86	0.69	0.63	0.56	0.46	0.40	0.37	0.35	0.33	0.32
50	1.00	1.00	1.00	0.86	0.77	0.67	0.52	0.44	0.39	0.37	0.35	0.33
60	1.00	1.00	1.00	0.97	0.86	0.75	0.57	0.47	0.41	0.38	0.36	0.34
75	1.00	1.00	1.00	1.00	1.00	0.86	0.64	0.51	0.44	0.41	0.37	0.35
125	1.00	1.00	1.00	1.00	1.00	1.00	0.86	0.65	0.53	0.48	0.42	0.38
200	1.00	1.00	1.00	1.00	1.00	1.00	1.00	0.86	0.67	0.58	0.49	0.42
300	1.00	1.00	1.00	1.00	1.00	1.00	1.00	1.00	0.86	0.72	0.58	0.49
400	1.00	1.00	1.00	1.00	1.00	1.00	1.00	1.00	1.00	0.86	0.67	0.55
500	1.00	1.00	1.00	1.00	1.00	1.00	1.00	1.00	1.00	1.00	0.77	0.61
600	1.00	1.00	1.00	1.00	1.00	1.00	1.00	1.00	1.00	1.00	0.86	0.67
900	1.00	1.00	1.00	1.00	1.00	1.00	1.00	1.00	1.00	1.00	1.00	0.86

Checkpoint **4a**

Design seismic cracked concrete edge shear resistance, $V_{Rd,c,seis}$

$$V_{Rd,c,seis} = V_{Rd,c,seis}^o * X_{vc} * X_{vd} * X_{ve} * X_{vs}$$

Checkpoint **4b**

Design seismic cracked concrete Pryout failure, $V_{Rd,cp,seis}$

$$V_{Rd,cp,seis} = V_{Rd,cp,seis}^o * X_{nc} * X_{ne} * X_{na}$$

STEP **5**

Verify cracked concrete shear resistance - per anchor

Table 5a-1 - Seismic (C1) Cracked Concrete steel shear resistance, $V_{Rk,s,seis} = \alpha_{seis} V_{Rk,s,seis} / \gamma_{Ms}$ (kN) where $\alpha_{seis} = 0.85$,

Anchor size, d_b	M10	M12	M16	M20
Carbon Steel	5.4	7.7	15.3	17.3
Stainless Steel	3.5	5.1	8.2	-

Carbon Steel:

$\gamma_{Ms,c1} = 1.27$ (M10 - M12)

$\gamma_{Ms,c1} = 1.25$ (M16)

$\gamma_{Ms,c1} = 1.5$ (M20)

Stainless Steel:

$\gamma_{Ms,c1} = 1.47$ (M10 - M12)

$\gamma_{Ms,c1} = 1.75$ (M16)

Note: Data includes annular gap reduction factor of 0.5

For single anchor values: Multiply $V_{Rk,c,seis}$ *1.17

Table 5a-2 - Seismic (C2) Cracked Concrete steel shear resistance, $V_{Rk,s,seis} = \alpha_{seis} V_{Rk,s,seis} / \gamma_{Ms}$ (kN) where $\alpha_{seis} = 0.85$,

Anchor size, d_b	M10	M12	M16	M20
Carbon Steel	3.2	4.7	11.5	12.7
Stainless Steel	2.1	3.1	6.1	-

Carbon Steel:

$\gamma_{Ms,c2} = 1.27$ (M10 - M12)

$\gamma_{Ms,c2} = 1.25$ (M16)

$\gamma_{Ms,c2} = 1.5$ (M20)

Stainless Steel:

$\gamma_{Ms,c2} = 1.47$ (M10 - M12)

$\gamma_{Ms,c2} = 1.75$ (M16)

Note: Data includes annular gap reduction factor of 0.5

For single anchor values: Multiply $V_{Rk,c,seis}$ *1.17

Checkpoint **5**

Design Seismic cracked concrete shear resistance, $V_{Rd,seis}$

$$V_{Rd,seis} = \text{Minimum of } V_{Rd,c,seis}, V_{Rd,cp,seis}, V_{Rd,s,seis}$$

Check $V^*/V_{Rd,seis} \leq 1$

if not satisfied return to step 1

TruBolt™ Xtrem™

STRENGTH LIMIT STATE DESIGN

STEP 6 Combined Loading

Checkpoint 6

Check

$N^*/N_{Rd,seis} + V^*/V_{Rd,seis} \leq 1.0,$
if not satisfied return to step 1

Specify

Ramset™ TruBolt™ Xtrem™ Anchor,
(Anchor Size) (Part Number)
Maximum fixed thickness to be (t) mm.

Example

Ramset™ TruBolt™ Xtrem™ Anchor, M12 T12115X.
Maximum fixed thickness to be 20mm. To be installed in
accordance with Ramset Installation Instructions.

Ramset™ iExpert Anchor Software for optimised calculation or where a greater range of anchor layout detail is needed.

AnkaScrew™ Xtrem™

SEISMIC - MECHANICAL SCREW-IN ANCHORS

[Back to index](#)

GENERAL INFORMATION

Performance Related	Material	Installation Related

Product

A seismic certified heavy duty screw-in anchor for permanent anchoring into concrete. Certified for seismic C1 & C2 applications.



Compliance

European Technical Assessment (option1) - ETA-20/0731

Design According to:

- AS5216 (formerly TS101)
- AS1170.4 - Earthquake Actions
- EN1992-4 (formerly ETAG001 Annex C, E & TR045)
- NZS3101 (A3) Section 17 - Seismic Design C1 & C2

For optimised performance data, please use Ramset iExpert Anchoring Software.

Benefits, Advantages and Features

Fire tested to TR020

- Fire rated performance up to 120 minutes
- Highest level of European assessment for mechanical screw-in anchors
- Approved for all directions (floor, wall, overhead)
- Maximum Tensile & Shear capacities in cracked concrete
- Zinc Flake Coating ($\geq 5\mu\text{m}$)
- Anchor diameters 6mm to 12mm

Fast and easy to use:

- Install, simply screws into hole.
- Remove leaving an empty hole.

Close to edge and for close anchor spacing:

- Does not expand and burst concrete.

Installation

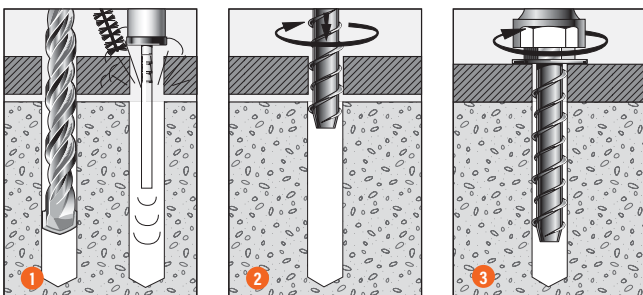

- Drill hole to correct diameter and depth. Important: Use **Ramset™ Dustless Drilling System** to ensure holes are clean. Alternatively, clean thoroughly with brush and remove debris by way of vacuum or hand pump, compressed air etc.
- Using a socket wrench, screw the AnkaScrew™ Xtrem™ into the hole using slight pressure until the self tapping action starts.
- Tighten the AnkaScrew™ Xtrem™ until flush with fixture. If resistance is experienced when tightening, unscrew anchor one turn and re-tighten. Ensure not to over tighten. Refer to tightening torque for limitations.



Principal Applications

- Seismic anchoring to Category C1/C2
- Anchoring into cracked & non cracked concrete
- Steel framing
- Mechanical services
- Pallet racking
- Safety barriers
- Conveyors
- Hand rails
- Bottom plates

Seismic Anchors - AnkaScrew™ Xtrem™

AnkaScrew™ Xtrem™

SEISMIC - MECHANICAL SCREW-IN ANCHORS

Seismic Anchors - AnkaScrew™ Xtrem™

Installation and performance details

Anchor size, d _b (mm)	Drilled hole diameter, d _h (mm)	Fixture hole diameter, d _f (mm)	Anchor effective depth, h (mm)	Depth of drill hole, h ₁ (mm)	Tightening torque, T _r (Nm)	Concrete substrate thickness, b _m (mm)#	C1 & C2-Seismic Cracked Concrete reduced characteristic tensile capacity*							
							Shear capacity, V _{Rd,seis} (kN)		Tensile capacity, N ⁰ _{Rd,c,seis} Or N ⁰ _{Rd,p,seis} (kN) **					
									Concrete Compressive Strength, f' _c					
							where f' _c ≥ 30 MPa		20 MPa		30 MPa		40 MPa	
C1	C2	C1	C2	C1	C2	C1	C2							
6	6	8	31	45	10	80	1.6	N/A	1.1	N/A	1.4	N/A	1.6	N/A
			44	60		90	1.9	N/A	2.3	N/A	2.8	N/A	3.2	N/A
8	8	12	52	75	20	105	2.9	3.5	6.5	1.31	7.9	1.60	9.1	1.85
10	10	14	43	65	40	90	3.0	N/A	4.8	N/A	5.9	N/A	6.8	N/A
			68	95		136	5.2	7.4	9.6	3.02	11.8	3.70	13.6	4.27
12	12	16	80	110	60	160	7.1	8.3	12.2	4.00	15.0	4.90	17.3	5.66

*Data is based on optimal dimensions, anchor spacing = 3*h, edge distance = 1.5*h

*For shear loads acting towards an edge or where optimum dimensions are not achievable, please use the simplified strength limit state design process to verify capacity.

**Note: For C1 values concrete cone capacity governs and for C2 values pull-out capacity governs.

Note: For performance based on smaller concrete substrate thickness, refer to iExpert Anchor Software or Ramset™ Engineer.

For shear loads acting towards an edge or where optimum dimensions are not achievable, please use the simplified strength limit state design process to verify capacity.

DESCRIPTION AND PART NUMBERS

Anchor size, d _b (mm)	Drilled hole diameter, d _h (mm)	Effective Length, L _e (mm)	Maximum Fixture Thickness, t _{fix,max} (mm)	AnkaScrew™ Xtrem™ Description	Part Number
6	6	41	10	6mmx50mm zinc flake coated	AS06050X
		71	40	6mmx80mm zinc flake coated	AS06080X
8	8	67	15	8mmx80mm zinc flake coated	AS08080X
10	10	48	5	10mmx60mm zinc flake coated	AS10060X
		88	45	10mmx100mm zinc flake coated	AS10100X
12	12	95	15	12mmx110mm zinc flake coated	AS12110X
		135	55	12mmx150mm zinc flake coated	AS12150X

Effective depth, h (mm)

$$h = L_e - t$$

t = total thickness of material(s) being fixed

ENGINEERING PROPERTIES

Anchor size, d _b (mm)	Minimum cross sectional diameter (mm)	Stress area, A _s (mm ²)	Yield strength, f _y (MPa)	UTS, f _u (Mpa)
6	5.1	20.4	560	700
8	7.1	39.6	560	700
10	9.1	65.0	560	700
12	11.1	96.8	560	700

AnkaScrew™ Xtrem™

SEISMIC - MECHANICAL SCREW-IN ANCHORS

STEP 1

Select anchor to be evaluated

Table 1a Indicative combined loading - interaction diagram

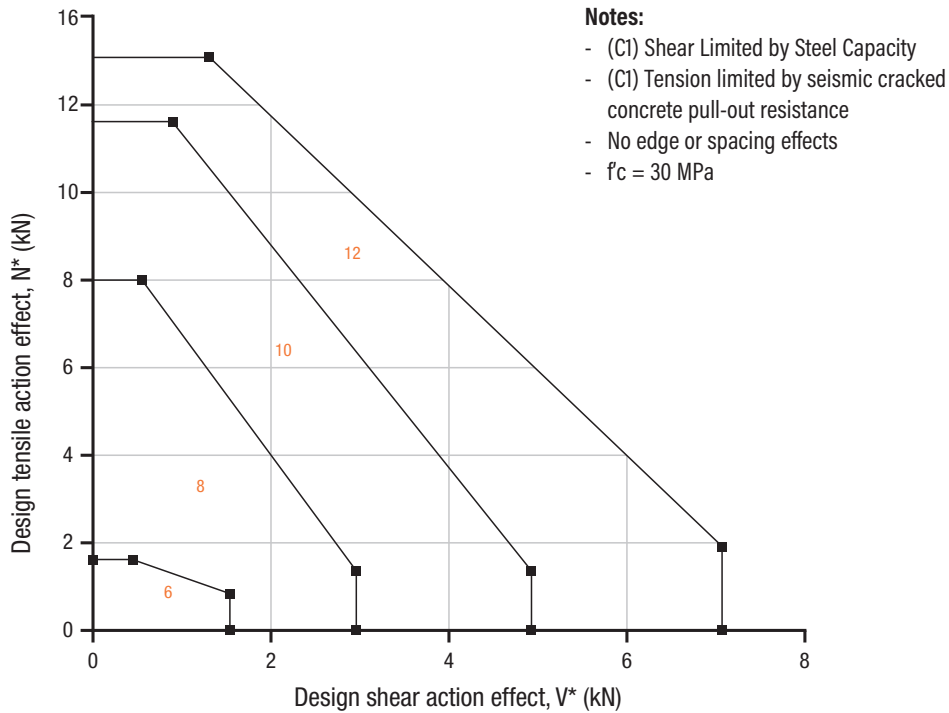

Table 1b Absolute minimum edge distance and anchor spacing values, e_m and a_m (mm)

Anchor size, d_b	6	8	10	12		
Effective depth, h (mm)	31	44	52	43	68	80
*Min. member thickness (mm)	80	90	105	90	136	160
Min. Anchor spacing - a_m	40	40	50	50	50	70
Min. Edge Distance - e_m	40	40	50	50	50	70

*Note: For calculations based on smaller member thickness, refer to iExpert Anchor Software or Ramset™ Engineer.

Step 1c Calculate anchor effective depth, h (mm)

Refer to "Description and Part Numbers" table in the SARB ANZ on the previous page .

Effective depth, h (mm)

$$h = L_e - t$$

t = total thickness of material(s) being fixed

Checkpoint 1

Anchor size determined, absolute minima compliance achieved, effective depth (h) calculated.

AnkaScrew™ Xtrem™

STRENGTH LIMIT STATE DESIGN

Seismic Anchors - AnkaScrew™ Xtrem™

STEP 2

Verify seismic cracked concrete cone tensile resistance - per anchor

Table 2a - Seismic Cracked concrete cone resistance, $N_{Rk,c,seis} = \alpha_{seis} N^0_{Rk,c,seis} / \gamma_{Msp}$ (kN), $\gamma_{Msp} = 1.5$, $f'_c = 30$ MPa, $\alpha_{seis} = 0.75$ where $N^0_{Rk,c} = k_1 * \sqrt{f'_c} * h_{ef}^{1.5}$

Anchor size, d_b	6	8	10	12
Drill hole dia, d_h (mm)	6	8	10	12
Effective depth, h (mm)				
31	3.6			
43			5.9	
44	6.1			
52		7.9		
68			11.8	
80				15.0

For single anchor values: Multiply $N_{Rk,c,seis}$ *1.13

For optimised performance data, please use Ramset iExpert Anchoring Software.

Table 2b - Seismic cracked concrete compressive strength effect, tension, X_{nc} and Pull-out, X_{npc}

f'_c (MPa)	20	25	30	40	50
Tension X_{nc}	0.82	0.91	1.00	1.15	1.29
Pull-out X_{npc}	0.82	0.91	1.00	1.15	1.29

Table 2c - Seismic cracked concrete Edge distance effect, tension, X_{ne}

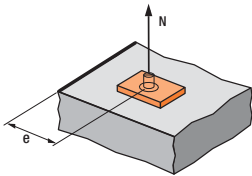

$$X_{ne} = 0.25 + 0.5 * (e/h)$$

Where $e_m \leq e \leq e_c$

$$e_c = 1.5 * h$$

Note: Tabled values are based on the nominal effective depth, h shown in the installation details. For other values of X_{ne} , please use equation shown above.

Anchor size, d_b	6		8	10		12
Effective depth, h (mm)	31	44	52	43	68	80
Edge distance, e (mm)						
40	0.90	0.70				
45	0.98	0.76				
50	1	0.82	0.73	0.83	0.62	
55		0.88	0.78	0.89	0.65	
65		0.99	0.88	1	0.73	
70		1	0.92		0.76	0.69
80			1		0.84	0.75
85					0.88	0.78
90					0.91	0.81
105					1	0.91
120						1

Table 2d - Seismic cracked concrete anchor spacing effect, tension, X_{na}

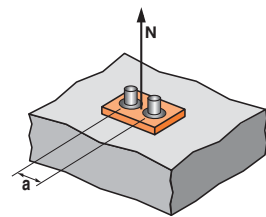

$$X_{na} = 0.5 + a / (6 * h)$$

Where $a_m \leq a \leq a_c$

$$a_c = 3 * h$$

Note: Tabled values are based on the nominal effective depth, h shown in the installation details. For other values of X_{na} , please use equation shown above.

Anchor size, d_b	6		8	10		12
Effective depth, h (mm)	31	44	52	43	68	80
Anchor spacing, a (mm)						
40	0.72	0.65				
45	0.74	0.67				
50	0.77	0.69	0.66	0.69	0.62	
65	0.85	0.75	0.71	0.75	0.66	
70	0.88	0.77	0.72	0.77	0.67	0.65
80	0.93	0.80	0.76	0.81	0.70	0.67
85	0.96	0.82	0.77	0.83	0.71	0.68
90	0.98	0.84	0.79	0.85	0.72	0.69
100	1	0.88	0.82	0.89	0.75	0.71
130		0.99	0.92	1	0.82	0.77
155		1	1		0.88	0.82
195					0.98	0.91
205					1	0.93
240						1

Checkpoint 2

Design cracked concrete cone resistance, $N_{Rd,c,seis}$

$$N_{Rd,c,seis} = N_{Rk,c,seis} * X_{nc} * X_{ne} * X_{na}$$

AnkaScrew™ Xtrem™

STRENGTH LIMIT STATE DESIGN

STEP 3

Verify cracked concrete tensile resistance tension - per anchor

Table 3a - Seismic (C1 & C2) Cracked Concrete steel resistance, tensile, $N_{Rd,s,seis} = \alpha_{seis} N_{Rk,s,seis} / \gamma_{Ms}$ (kN) where $\alpha_{seis} = 1.0$, $\gamma_{Ms} = 1.5$

Anchor size, d_b	6	8	10	12
Carbon Steel	9.3	18.0	30.0	44.7

Table 3b-1 - Seismic (C1) Cracked concrete Pull-out resistance**, $N_{Rd,p,seis}^0 = \alpha_{seis} N_{Rk,p,seis}^0 / \gamma_{Msp}$ (kN)
 $\gamma_{Msp} = 1.5, \alpha_{seis} = 0.85, f'_c = 30 \text{ MPa}$

Anchor size, d_b	6	8	10	12
Drill hole dia, d_h (mm)	6	8	10	12
Effective depth, h (mm)				
31	1.4			
43			6.2	
44	2.8			
52		8.2		
68			N/A	
80				N/A

**Cracked concrete Pull-out resistance is not influenced by reduced anchor spacing or edge distance.

For single anchor values: Multiply $N_{Rk,p,seis}$ *1.17

Table 3b-2 - Seismic (C2) Cracked concrete Pull-out resistance**, $N_{Rd,p,seis}^0 = \alpha_{seis} N_{Rk,p,seis}^0 / \gamma_{Msp}$ (kN)
 $\gamma_{Msp} = 1.5, \alpha_{seis} = 0.85, f'_c = 30 \text{ Mpa}$

Anchor size, d_b	8	10	12
Drill hole dia, d_h (mm)	8	10	12
Effective depth, h (mm)			
52	1.6		
68		3.7	
80			4.9

** Cracked concrete Pull-out resistance is not influenced by reduced anchor spacing or edge distance.

For single anchor values: Multiply $N_{Rd,c,seis}$ *1.17

Checkpoint 3a

Design Seismic cracked concrete pull-out resistance, $N_{Rd,p,seis}$

$$N_{Rd,p,seis} = N_{Rd,p,seis}^0 * X_{npc}$$

Checkpoint 3b

Design Seismic cracked concrete tensile resistance, $N_{Rd,seis}$

$$N_{Rd,seis} = \text{Minimum of } N_{Rd,c,seis}, N_{Rd,p,seis}, N_{Rd,s,seis}$$

Check $N^*/N_{Rd,seis} \leq 1$

if not satisfied return to step 1

AnkaScrew™ Xtrem™

STRENGTH LIMIT STATE DESIGN

Seismic Anchors - AnkaScrew™ Xtrem™

STEP 4

Verify cracked concrete edge shear resistance - per anchor

Table 4a - Seismic cracked concrete edge resistance, $V_{Rd,c,seis}^0 = \alpha_{seis} * V_{Rk,c,seis}^0 / \gamma_{Mc}$ (kN)

$\gamma_{Mc} = 1.5, \alpha_{seis} = 0.85, f'_c = 30 \text{ MPa}$

Anchor size, d_b	6	8	10	12
Effective depth, h (mm)	31	44	52	80
Edge distance, e_m				
40	1.0	1.0		
50		1.5	1.5	1.7
70				2.7

Note: Data includes annular gap reduction factor of 0.5

For single anchor values: Multiply $V_{Rd,c,seis}^0 * 1.17$

For optimised performance data, please use Ramset iExpert Anchoring Software.

Table 4b - Seismic cracked concrete compressive strength effect, shear, X_{vc}

f'_c (MPa)	20	25	30	40	50
X_{vc}	0.82	0.91	1	1.15	1.29

Table 4c - Seismic cracked concrete load direction effect, concrete edge shear, X_{vd}

Angle, α°	0-55	60	70	80	90-180
X_{vd}	1	1.1	1.2	1.5	2

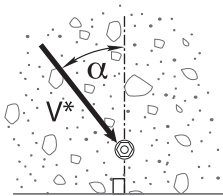

Load direction effect, conc. edge shear, X_{vd}

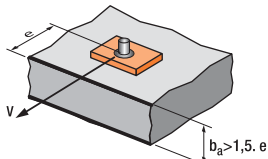

$$X_{ve} = e/e_m * \sqrt{e/e_m}$$

Table 4d - Seismic cracked concrete anchor spacing and edge distance effect, concrete edge shear, X_{ve}

For single anchor fastening X_{ve}

e/e_m	1.0	1.2	1.4	1.6	1.8	2.0	2.2	2.4	2.6	2.8	3.0	3.2
X_{ve}	1.00	1.31	1.66	2.02	2.41	2.83	3.26	3.72	4.19	4.69	5.20	5.72

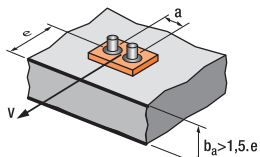

$$X_{ve} = \frac{3 * e + a}{6 * e_m} * \sqrt{e/e_m}$$

For 2 anchors fastening X_{ve}

e/e_m	1.0	1.2	1.4	1.6	1.8	2.0	2.2	2.4	2.6	2.8	3.0	3.2
a/e_m												
1.0	0.67	0.84	1.03	1.22	1.43	1.65	1.88	2.12	2.36	2.62	2.89	3.16
1.5	0.75	0.93	1.12	1.33	1.54	1.77	2.00	2.25	2.50	2.76	3.03	3.31
2.0	0.83	1.02	1.22	1.43	1.65	1.89	2.12	2.38	2.63	2.90	3.18	3.46
2.5	0.92	1.11	1.32	1.54	1.77	2.00	2.25	2.50	2.77	3.04	3.32	3.61
3.0	1.00	1.20	1.42	1.64	1.88	2.12	2.37	2.63	2.90	3.18	3.46	3.76
3.5		1.30	1.52	1.75	1.99	2.24	2.50	2.76	3.04	3.32	3.61	3.91
4.0			1.62	1.86	2.10	2.36	2.62	2.89	3.17	3.46	3.75	4.05
4.5				1.96	2.21	2.47	2.74	3.02	3.31	3.60	3.90	4.20
5.0					2.33	2.59	2.87	3.15	3.44	3.74	4.04	4.35
5.5						2.71	2.99	3.28	3.71	4.02	4.33	4.65
6.0							2.83	3.11	3.41	3.71	4.02	4.33

For 3 anchors fastening and more X_{ve}

$$X_{ve} = \frac{3 * e + a_1 + a_2 + a_3 + \dots + a_{n-1}}{3 * n * e_m} * \sqrt{e/e_m}$$

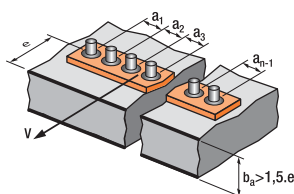

AnkaScrew™ Xtrem™

STRENGTH LIMIT STATE DESIGN

Seismic Anchors - AnkaScrew™ Xtrem™

Table 4e - Seismic Cracked concrete Pryout failure, $V_{Rd,cp,seis}^0 = \alpha_{seis} V_{Rk,cp,seis} / \gamma_{Mpr}$ (kN)

$\gamma_{Mpr} = 1.5, \alpha_{seis} = 0.75, f'_c = 30 \text{ MPa}$

Anchor size, d_b	6	8	10	12
Effective depth, h (mm)				
31	1.8			
43			3.0	
44	3.1			
52		4.0		
68			11.8	
80				15.1

Note: Data includes annular gap reduction factor of 0.5

For single anchor values: Multiply $V_{Rd,c,seis}^0 * 1.13$

Table 4f - Anchor at a corner effect, concrete edge shear, X_{VS}

Note: For $e_1/e_2 > 1.25, X_{VS} = 1.0$

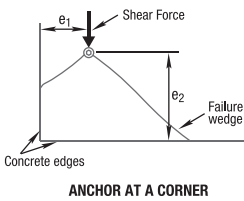

Edge distance, e_2 (mm)	25	30	35	50	60	75	125	200	300	400	600	900
Edge distance, e_1 (mm)												
25	0.86	0.77	0.70	0.58	0.53	0.49	0.41	0.37	0.35	0.34	0.32	0.32
30	0.97	0.86	0.78	0.64	0.58	0.52	0.43	0.38	0.36	0.34	0.33	0.32
35	1.00	0.95	0.86	0.69	0.63	0.56	0.46	0.40	0.37	0.35	0.33	0.32
50	1.00	1.00	1.00	0.86	0.77	0.67	0.52	0.44	0.39	0.37	0.35	0.33
60	1.00	1.00	1.00	0.97	0.86	0.75	0.57	0.47	0.41	0.38	0.36	0.34
75	1.00	1.00	1.00	1.00	1.00	0.86	0.64	0.51	0.44	0.41	0.37	0.35
125	1.00	1.00	1.00	1.00	1.00	1.00	0.86	0.65	0.53	0.48	0.42	0.38
200	1.00	1.00	1.00	1.00	1.00	1.00	1.00	0.86	0.67	0.58	0.49	0.42
300	1.00	1.00	1.00	1.00	1.00	1.00	1.00	1.00	0.86	0.72	0.58	0.49
400	1.00	1.00	1.00	1.00	1.00	1.00	1.00	1.00	1.00	0.86	0.67	0.55
500	1.00	1.00	1.00	1.00	1.00	1.00	1.00	1.00	1.00	1.00	0.77	0.61
600	1.00	1.00	1.00	1.00	1.00	1.00	1.00	1.00	1.00	1.00	0.86	0.67
900	1.00	1.00	1.00	1.00	1.00	1.00	1.00	1.00	1.00	1.00	1.00	0.86

Checkpoint 4a

Design seismic cracked concrete edge shear resistance, $V_{Rd,c,seis}$

$$V_{Rd,c,seis} = V_{Rd,c,seis}^0 * X_{vc} * X_{vd} * X_{ve} * X_{vs}$$

Checkpoint 4b

Design seismic cracked concrete Pryout failure, $V_{Rd,cp,seis}$

$$V_{Rd,cp,seis} = V_{Rd,cp,seis}^0 * X_{nc} * X_{ne} * X_{na}$$

STEP 5

Verify cracked concrete shear resistance - per anchor

Table 5a-1 - Seismic (C1) Cracked Concrete steel shear resistance, $V_{Rd,s,seis} = \alpha_{seis} V_{Rk,s,seis} / \gamma_{Ms}$ (kN) where

$\alpha_{seis} = 0.85, \gamma_{Ms} = 1.25$

Anchor size, d_b	6	8	10	12
Effective depth, h (mm)	31	44	52	68
Carbon Steel	1.6	1.9	2.9	4.6

Note: Data includes annular gap reduction factor of 0.5.

For single anchor multiply $V_{Rd,c,seis} \times 1.17$

Table 5a-2 - Seismic (C2) Cracked Concrete steel shear resistance, $V_{Rd,s,seis} = \alpha_{seis} V_{Rk,s,seis} / \gamma_{Ms}$ (kN) where

$\alpha_{seis} = 0.85, \gamma_{Ms} = 1.25$

Anchor size, d_b	8	10	12
Effective depth, h (mm)	52	68	80
Carbon Steel (with annular gap)	3.5	7.4	8.3
Carbon Steel (annular gap being filled)	6.7	12.6	21.5

For single anchor multiply $V_{Rd,s,seis} \times 1.17$

Checkpoint 5

Design Seismic cracked concrete shear resistance, $V_{Rd,seis}$

$$V_{Rd,seis} = \text{Minimum of } V_{Rd,c,seis}, V_{Rd,cp,seis}, V_{Rd,s,seis}$$

Check $V^*/V_{Rd,seis} \leq 1$

if not satisfied return to step 1

AnkaScrew™ Xtrem™

STRENGTH LIMIT STATE DESIGN

Seismic Anchors - AnkaScrew™ Xtrem™

STEP 6

Combined Loading

Checkpoint 6

Check

$$N^*/N_{Rd,seis} + V^*/V_{Rd,seis} \leq 1.0,$$
 if not satisfied return to step 1

Specify
 Ramset™ AnkaScrew™ Xtrem™ Anchor,
 (Anchor Size) (Part Number)
 Maximum fixed thickness to be (t) mm.

Example
 Ramset™ AnkaScrew™ Xtrem™ Anchor, 12mm AS12110X.
 Maximum fixed thickness to be 15mm. To be installed in
 accordance with Ramset Installation Instructions.

Ramset™ iExpert Anchor Software for optimised calculation or where a greater range of anchor layout detail is needed.

Introduction

SEISMIC ANCHORS - COMPOSITE FLOORING APPLICATION



AnkaScrew™ & TruBolt™ Xtrem™

Anchoring Solutions for
Composite Flooring Application



MULTI
DIRECTIONAL
APPLICATION



Seismic Anchors - Composite Flooring Application



Composite steel floor decking system (such as ComFlor®) is highly popular due to its performance, simplicity & Efficiency. Ramset™ had conducted testing on a range of seismic mechanical anchors, installed on the ComFlor® system to determine their performance and enable Engineers to design these anchors into their projects.

The anchors included in this technical datasheet are TruBolt™ Xtrem™ and AnkaScrew™ Xtrem Range. The data presented has been analysed and interpreted in alignment with the ACI355.2, ACI193, NZS4219 and the European Technical Assessment (ETA) documents of the products.

Anchor Design

Scan for more information

Specifiers
Anchoring
Resource Book



AnkaScrew™ Xtrem™

SEISMIC - MECHANICAL SCREW-IN ANCHORS COMPOSITE FLOORING APPLICATION

Back to index



Installation and Seismic Performance Details for Composite Flooring System

Seismic Anchors - AnkaScrew™ Xtrem™

Anchor Designation		Installation details								Optimum dimensions*		Composite Metal Deck Detail (ComFlor® 60 & ComFlor® 80)				
Anchor Size, d _a (mm)	Anchor Location	Drilled hole diam., d _h (mm)	Fixture hole diameter, d _f (mm)	Max. Fixture Thickness, t _{max} (mm)	Anchor effective depth, h _{ef} (mm)	Drill hole depth, h _d (mm)	Tight'g torque, T (Nm)	***Edge distance, e _c (mm)	***Anchor spacing, a _c (mm)	Min. Steel gauge thk (mm)	Section Dimensions					
											Min. concrete thickness h _{min,deck} (mm)	Max. Offset from Centre of lower flute (mm)	Max. depth of lower flute, h _{l,max} (mm)	Min. width of lower flute, W _{min} (mm)		
6	Upper Flute	6	8	9	31	45	10	47	93	0.9	90	N/A	N/A	N/A		
	Lower Flute										N/A	10	80	120		
8	Upper Flute	8	12	14	52	75	20	78	156	0.9	90	N/A	N/A	N/A		
	Lower Flute										N/A	10	80	120		
10	Upper Flute	10	14	4	43	65	40	65	129	0.9	90	N/A	N/A	N/A		
	Lower Flute										N/A	10	80	120		

Anchor Designation		Seismic C1 Cracked Concrete reduced characteristic capacity (per anchor) #									
Anchor Size, d _a (mm)	Anchor Location	Tension, N _{Rd,deck,seis} (kN)						Shear PARALLEL to deck, V _{Rd,deck,seis,PAR.} (kN) **		Shear PERPENDICULAR to deck, V _{Rd,deck,seis,PERP.} (kN) **	
		Concrete compressive strength, f'c						Concrete compressive strength, f'c		Concrete compressive strength, f'c	
		30 MPa		35 MPa		40 MPa		≥ 30 MPa		≥ 30 MPa	
		Single Anchor	Anchor Group	Single Anchor	Anchor Group	Single Anchor	Anchor Group	Single Anchor	Anchor Group	Single Anchor	Anchor Group
6	Upper Flute	2.6	2.2	2.8	2.4	3.0	2.5	3.8	3.2	3.8	3.2
	Lower Flute	3.5	3.1	3.8	3.4	4.1	3.6	3.8	3.2	3.8	3.2
8	Upper Flute	18.0						6.8	5.8	6.8	5.8
	Lower Flute	18.0						6.8	5.8	6.8	5.8
10	Upper Flute	7.6	6.5	8.2	7.0	8.8	7.5	10.8	9.2	10.8	9.2
	Lower Flute	5.4	4.7	5.8	5.1	6.2	5.5	11.8	10.0	11.8	10.0

NOTE: Performance Data is based on test program in accordance with ACI 355.2 and conducted at University of Auckland in June 2021. Refer to report FTA-21/0005 for the Fastener Technical Assessment of the test results.

* Where optimum dimensions are not achievable please contact Ramset to verify capacities.

** For applications where the annular gap between the fastener and the fixture cannot be eliminated, multiply V_{Rd,deck,seis} x 0.5

*** Optimum dimensions for the lower flute are along the longitudinal direction where anchors are located within the Maximum Offset from the centre of the lower flute.

Note 1. N_{Rd,deck,seis} = α_{seis} * N_{Rk,seis} / γ_{1a} where N_{Rk,seis} is the basic characteristic seismic resistance for a given tensile failure mode and α_{seis} is the seismic reduction factor associated with cracking of concrete cone resistance for single anchors and groups of anchors. Furthermore γ_{1a} is the partial safety factor relevant for the tensile failure mode.

Note 2. V_{Rd,deck,seis} = α_{seis} * V_{Rk,seis} / γ_{1a} where V_{Rk,seis} is the basic characteristic seismic resistance for a given shear failure mode and α_{seis} is the seismic reduction factor associated with cracking of concrete cone resistance for single anchors and groups of anchors. Furthermore γ_{1a} is the partial safety factor relevant for the shear failure mode.

Installation

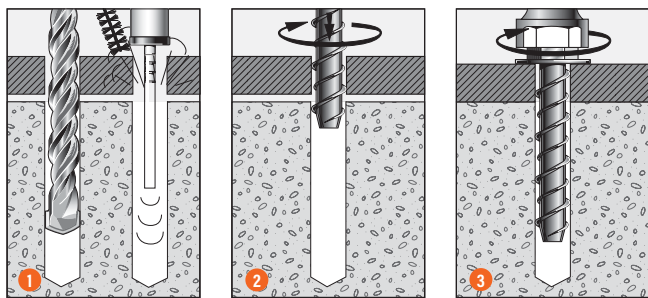

1. Drill hole to correct diameter and depth. Important: Use Ramset™ Dustless Drilling System to ensure holes are clean. Alternatively, clean clean thoroughly with brush and remove debris by way of vacuum or hand pump, compressed air etc.
2. Using a socket wrench, screw the AnkaScrew™ Xtrem™ into the hole using slight pressure until the self tapping action starts.
3. Tighten the AnkaScrew™ Xtrem™ until flush with fixture.
If resistance is experienced when tightening, unscrew anchor one turn and re-tighten. Ensure not to over tighten. Refer to tightening torque for limitations.

AnkaScrew™ Xtrem™

Anchor fixing location to composite/metal deck slab soffit

(ComFlor 60 & ComFlor 80 shown below)

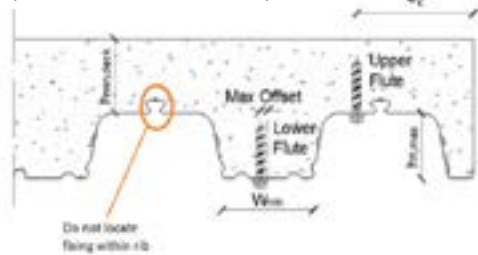

Anchor Size d _a (mm)	Drilled hole diam., d _h (mm)	Effective Length, L _e (mm)	Max. Fixture Thickness, t _{max} (mm)	Min. Steel Gauge thk for Steel Deck t _{sd} (mm)	AnkaScrew™ Xtrem™ Description	Part Number
6	6	41	9	0.9	6mm x 50mm zinc	AS06050X
8	8	67	14	0.9	8mm x 80mm zinc	AS08080X
10	10	48	4	0.9	10mm x 60mm zinc	AS10060X

Effective depth h_{ef} (mm)

$$h_{ef} = L_e - t$$

t = total thickness of material(s) being fixed (t_{max} + t_{sd})

AnkaScrew™ Xtrem™ Rod Holder™

SEISMIC - MECHANICAL SCREW-IN ANCHORS COMPOSITE FLOORING APPLICATION

[Back to index](#)



Seismic

Installation and Seismic Performance Details for Composite Flooring System

Anchor Designation		Installation details					Optimum dimensions*			Composite Metal Deck Detail (ComFlor® 60 & ComFlor® 80)				
Anchor Size, d _a (mm)	Anchor Location	Drilled hole diam., d _h (mm)	**Metric Threads suitable for Rod Holder Fixing	Anchor effective depth, h _{ef} (mm)	Drill hole depth, h _t (mm)	Tight'g torque, T _t (Nm)	***Edge distance, e _c (mm)	***Anchor spacing, a _c (mm)	Section Dimensions					
									Min. Steel Gauge thk (mm)	Min. concrete thickness h _{min,deck} (mm)	Max. Offset from Centre of lower flute (mm)	Max. depth of lower flute, h _{l,max} (mm)	Min. width of lower flute, W _{min} (mm)	
6	Upper Flute	6	M8 and M10	44	60	10	66	132	0.9	90	N/A	N/A	N/A	
	Lower Flute									N/A	10	80	120	

Anchor Designation		Seismic CI Cracked Concrete reduced characteristic capacity (per anchor) #					
Anchor Size, d _a (mm)	Anchor Location	Tension, N _{Rd,deck,seis} (kN)		Shear PARALLEL to deck, V _{Rd,deck,seis,PAR.} (kN)		Shear PERPENDICULAR to deck, V _{Rd,deck,seis,PERP.} (kN)	
		Concrete compressive strength, f _c		Concrete compressive strength, f _c		Concrete compressive strength, f _c	
		≥ 30 MPa		≥ 30 MPa		≥ 30 MPa	
		Single Anchor	Anchor Group	Single Anchor	Anchor Group	Single Anchor	Anchor Group
6	Upper Flute	9.3	9.3	4.4	3.7	4.4	3.7
	Lower Flute	9.3	9.3	4.4	3.7	4.4	3.7

NOTE: Performance Data is based on test program in accordance with ACI 355.2 and conducted at University of Auckland in June 2021. Refer to report FTA-21/0005 for the Fastener Technical Assessment of the test results.

* Where optimum dimensions are not achievable please contact Ramset to verify capacities

** Metric Threaded Rod Steel Tensile and Shear Capacities need to be checked against the AnkaScrew Rod Hanger Tensile and Shear Capacities and use the Minimum value of the two.

*** Optimum dimensions for the lower flute are along the longitudinal direction where anchors are located within the Maximum Offset from the centre of the lower flute

Note 1. $N_{Rd,deck,seis} = \alpha_{seis} * N_{Rd,seis} / \gamma_{Rd}$ where $N_{Rd,seis}$ is the basic characteristic seismic resistance for a given tensile failure mode and α_{seis} is the seismic reduction factor associated with cracking of concrete cone resistance for single anchors and groups of anchors. Furthermore γ_{Rd} is the partial safety factor relevant for the tensile failure mode.

Note 2. $V_{Rd,deck,seis} = \alpha_{seis} * V_{Rd,seis} / \gamma_{Rd}$ where $V_{Rd,seis}$ is the basic characteristic seismic resistance for a given shear failure mode and α_{seis} is the seismic reduction factor associated with cracking of concrete cone resistance for single anchors and groups of anchors. Furthermore γ_{Rd} is the partial safety factor relevant for the shear failure mode.

Installation

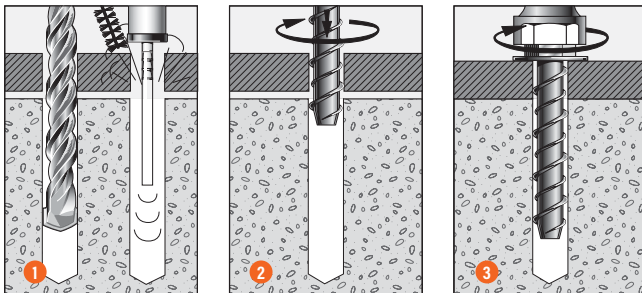

1. Drill hole to correct diameter and depth. Important: Use Ramset™ Dustless Drilling System to ensure holes are clean. Alternatively, clean clean thoroughly with brush and remove debris by clean of vacuum or hand pump, compressed air etc.
2. Using a socket wrench, screw the AnkaScrew™ Xtrem™ into the hole using slight pressure until the self tapping action starts.
3. Tighten the AnkaScrew™ Xtrem™ until flush with fixture.
If resistance is experienced when tightening, unscrew anchor one turn and re-tighten. Ensure not to over tighten. Refer to tightening torque for limitations.

AnkaScrew™ Xtrem™ Rod Holder

Anchor fixing location to composite/metal deck slab soffit

(ComFlor 60 & ComFlor 80 shown below)

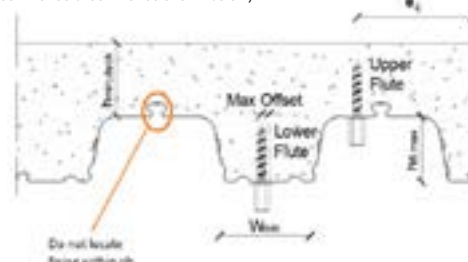

Description and Part Numbers

Anchor Size d _a (mm)	Drilled hole diam., d _h (mm)	Metric Threads suitable for Rod Holder Fixing	AnkaScrew™ Xtrem™ Rod Holder Description	Part Number
6	6	M8 and M10	6mm x 55mm zinc	AS06055XM810

TruBolt™ Xtrem™

SEISMIC - MECHANICAL ANCHORS COMPOSITE FLOORING APPLICATION

Back to index



Seismic Anchors - TruBolt™ Xtrem™

Installation and Seismic Performance Details for Composite Flooring System

Anchor Designation		Installation details						Optimum dimensions*		Composite Metal Deck Detail (ComFlor® 60 & ComFlor® 80)				
Anchor Size, d _s (mm)	Anchor Location	Drilled hole diam., d _h (mm)	Fixture hole diameter, d _f (mm)	Max. Fixture Thickness, t _{max} (mm)	Anchor effective depth, h _{ef} (mm)	Drill hole depth, h _i (mm)	Tight'g torque, T _r (Nm)	***Edge distance, e _c (mm)	***Anchor spacing, a _c (mm)	Section Dimensions				
										Min. Steel Gauge thk (mm)	Min. concrete thickness h _{min,deck} (mm)	Max. Offset from Centre of lower flute (mm)	Max. depth of lower flute, h _{l,max} (mm)	Min. width of lower flute, W _{min} (mm)
M10	Upper Flute	10	12	Refer Description Part No. Table	60	75	45	90	180	0.9	100	N/A	N/A	N/A
	Lower Flute										N/A	No offset tested	80	120
M12	Upper Flute	12	14	Refer Description Part No. Table	70	90	60	105	210	0.9	100	N/A	N/A	N/A
	Lower Flute										N/A	No offset tested	80	120

Anchor Designation		Seismic CI Cracked Concrete reduced characteristic capacity (per anchor) #																	
Anchor Size, d _s (mm)	Anchor Location	Tension, N _{Rd,deck,seis} (kN)						Shear PARALLEL to deck, V _{Rd,deck,seis,PAR} (kN) **						Shear PERPENDICULAR to deck, V _{Rd,deck,seis,PERP} (kN)**					
		Concrete compressive strength, f _c						Concrete compressive strength, f _c						Concrete compressive strength, f _c					
		30 MPa		35 MPa		40 MPa		30 MPa		35 MPa		40 MPa		30 MPa		35 MPa		40 MPa	
		Single Anchor	Anchor Group	Single Anchor	Anchor Group	Single Anchor	Anchor Group	Single Anchor	Anchor Group	Single Anchor	Anchor Group	Single Anchor	Anchor Group	Single Anchor	Anchor Group	Single Anchor	Anchor Group	Single Anchor	Anchor Group
M10	Upper Flute	2.1	1.8	2.3	2.0	2.5	2.1	12.6	10.7	12.6	10.7	12.6	10.7	12.6	10.7	12.6	10.7	12.6	10.7
	Lower Flute	3.8	3.3	3.9	3.5	4.0	3.5	3.2	2.7	3.3	2.8	3.4	2.9	6.8	5.8	7.1	6.0	7.2	6.1
M12	Upper Flute	8.8	7.5	9.5	8.0	10.1	8.6	18.1	15.4	18.1	15.4	18.1	15.4	18.1	15.4	18.1	15.4	18.1	15.4
	Lower Flute	5.1	4.5	5.3	4.7	5.4	4.8	7.2	6.1	7.4	6.3	7.6	6.5	5.8	4.9	6.0	5.1	6.1	5.2

NOTE: Performance Data is based on test program in accordance with ACI 355.2 and conducted at University of Auckland in October 2017. Refer to report FTA-21/0005 for the Fastener Technical Assessment of the test results.
 * Where optimum dimensions are not achievable please contact Ramset to verify capacities.
 ** For applications where the annular gap between the fastener and the fixture cannot be eliminated, multiply V_{Rd,deck,seis} x 0.5
 *** Optimum dimensions for the lower flute are along the longitudinal direction where anchors are located within the Maximum Offset from the centre of the lower flute.
 # Note 1. N_{Rd,deck,seis} = α_{seis} N_{Rk,seis} / γ_M where N_{Rk,seis} is the basic characteristic seismic resistance for a given tensile failure mode and α_{seis} is the seismic reduction factor associated with cracking of concrete cone resistance for single anchors and groups of anchors. Furthermore γ_M is the partial safety factor relevant for the tensile failure mode.
 # Note 2. V_{Rd,deck,seis} = α_{seis} V_{Rk,seis} / γ_M where V_{Rk,seis} is the basic characteristic seismic resistance for a given shear failure mode and α_{seis} is the seismic reduction factor associated with cracking of concrete cone resistance for single anchors and groups of anchors. Furthermore γ_M is the partial safety factor relevant for the shear failure mode.

Installation

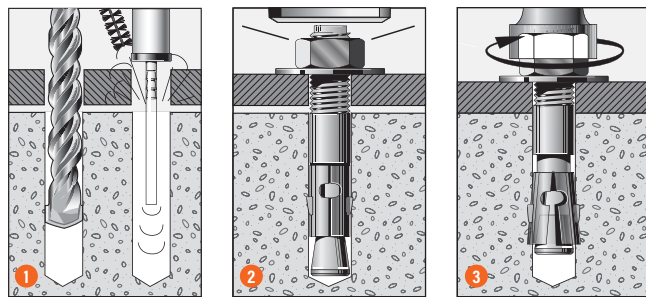

1. Drill hole to correct diameter and depth. Important: Use Ramset™ Dustless Drilling System to ensure holes are clean. Alternatively, clean thoroughly with brush and remove debris by way of vacuum or hand pump, compressed air etc.
2. Insert the TruBolt™ Xtrem™ through the fixture and drive with a hammer until washer contacts the fixture.
3. Tighten the TruBolt™ Xtrem™ nut with a torque wrench to specified assembly torque.

TruBolt™ Xtrem™

Anchor fixing location to composite/metal deck slab soffit

(ComFlor 60 & ComFlor 80 shown below)

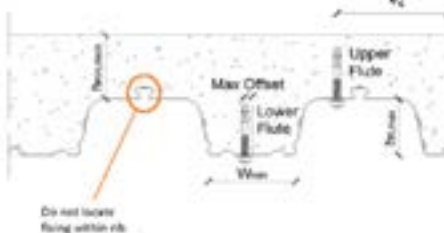

Anchor Size d _s (mm)	Drilled hole diam., d _h (mm)	Effective Length, L _e (mm)	Max. Fixture Thickness, t _{max} (mm)	Min. Steel Gauge thk for Steel Deck t _{sd} (mm)	TruBolt™ Xtrem™ Description	Part Number
M10	10	65	4	0.9	10mm x 85mm zinc	T10085X
		80	19		10mm x 100mm zinc	T10100X
M12	12	80	9	0.9	12mm x 105mm zinc	T12105X
		90	19		12mm x 115mm zinc	T12115X

Effective depth h_{ef} (mm)

$$h_{ef} = L_e - t$$

t = total thickness of material(s) being fixed (t_{max} + t_{sd})

Introduction

CHEMICAL ANCHORING - ANCHOR STUDS

[Back to index](#)

Chemical Anchoring - Anchor Studs

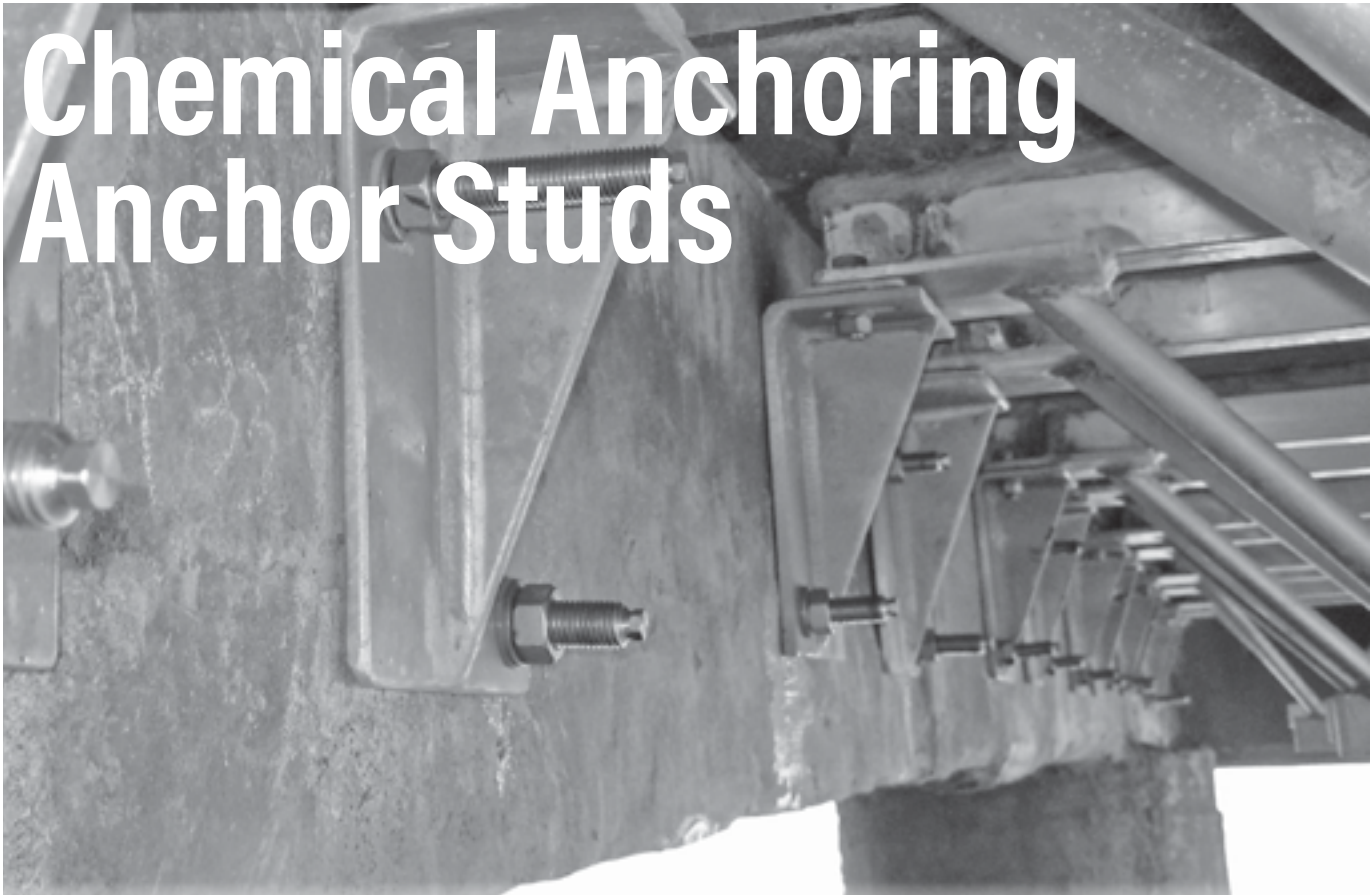

Chemical Anchoring Anchor Studs

The key advantage of ChemSet™ chemical anchors is that they do not impact an expansion stress on the surrounding substrate. This makes chemical anchoring ideal for close to edge fixings or for close anchor spacings.

The superior bond of ChemSet™ chemical anchors makes them ideal for installing starter bars, because the required pull out strength is achieved in shallower holes than is possible with cementitious mortars.

The ability of ChemSet™ chemical anchors to sustain cyclic tensile loads depends on adhesive bond, not on preload or tightening torque.

The adhesive bond does not deteriorate or change over time making ChemSet™ chemical anchors ideal for cyclic and vibrating load cases.

The superior strength of grade 5.8 carbon steel threaded stud anchors gives the ChemSet™ chemical anchor systems greater steel capacity than regular grade 4.6 threaded rod.

The Ramset™ ChemSet™ range of chemical anchoring systems provide different options of cost and performance for the designer and for the applicator.

For the designer, selection of the correct chemical anchoring solution to his or her design problem will often be based upon the strength capacity of the system, but may also involve issues such as chemical resistance.

The following section introduces the designer and/or engineer to the components of the ChemSet™ chemical anchoring range and provides information to allow selection of the anchor with the right capacity for various environmental conditions.

Estimating Chart

Fixings per cartridge for ChemSet™ Injection:

Anchor size	Nominal hole diameter (mm)	Nominal hole depth mm	Number of fixings						
			Epcon™ C8	Reo 502™ Plus	Epcon™ C6 Plus	ChemSet™ 801		ChemSet™ 101	
			450ml	600ml	600ml	Cartridge	Jumbo	Cartridge	Jumbo
M10	12	90	76	103	103	62	132	66	133
M12	14	110	49	67	67	41	86	43	87
M16	18	125	31	43	43	26	54	27	55
M20	24	150	12	17	17	10	22	11	22
M24	26	160	13	18	18	11	24	12	24

ChemSet™ Anchor Studs

CHEMICAL ANCHORING - ANCHOR STUDS

General Information

Product

Steel threaded studs for use with all ChemSet™ anchoring products, capsules and injection adhesives.

Benefits, Advantages and Features

Ensures maximum performance from ChemSet™ chemical anchors:

Zinc plated and Hot Dip Gal ChemSet™ Anchor studs made from high performance Grade 5.8 Steel.

Superior corrosion resistance:

Stainless Steel ChemSet™ Anchor studs made from AISI 316(A4) Stainless Steel

Outstanding exterior resistance:

- 42 micron Hot Dip Galvanised.

Convenient:

- Supplied with nuts and washers and setting tool for spin capsules.
- Depth setting mark to ensure correct embedment.

Material Specification

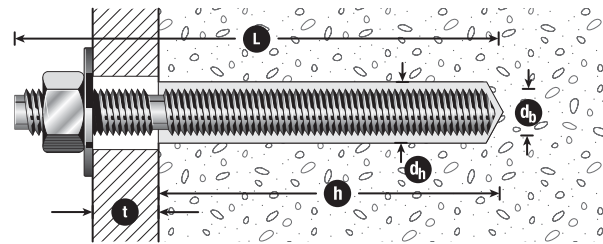

Description and Part Numbers

ChemSet™ Anchor Studs

Thread Size	Description	Zn ZINC	GAL Galvanised	A4 316 Stainless Steel 316	Box Quantity
M10	ChemSet™ Anchor Stud M10 x 130	CS10130	CS10130GH	CS10130SS	10
M12	ChemSet™ Anchor Stud M12 x 160	CS12160	CS12160GH	CS12160SS	10
M12	ChemSet™ Anchor Stud M12 x 180	CS12180			10
M16	ChemSet™ Anchor Stud M16 x 190	CS16190	CS16190GH	CS16190SS	10
M20	ChemSet™ Anchor Stud M20 x 260	CS20260	CS20260GH	CS20260SS	6
M24	ChemSet™ Anchor Stud M24 x 300	CS24300	CS24300GH	CS24300SS	6

Other sizes and steel types available on request. (Maybe subject to lead time)

Engineering Properties

ChemSet™ Anchor Studs - Typical Properties

See working loads of each anchoring adhesive in previous pages				Carbon Steel		Stainless Steel		Section Modulus, Z (mm³)
Thread Size	Overall Length, L (mm)	Effective Length, L _e (mm)	Max Fixture Thickness, t (mm)	Yield Strength, f _y (MPa)	Carbon Steel UTS, f _u (MPa)	Yield Strength, f _y (MPa)	Stainless Steel UTS, f _u (MPa)	
M10	130	115	25	430	540	450	650	62.3
M12	160	140	30	430	540	450	650	109.2
M12	180	160	50	430	540	450	650	109.2
M16	190	165	40	420	520	450	650	277.5
M20	260	225	80	420	520	450	650	540.9
M24	300	265	105	420	520	450	650	935.5

ChemSet™ Reo 502™ PLUS

CHEMICAL INJECTION - NON-CRACKED & CRACKED CONCRETE

Back to index

AVAILABLE IN AUSTRALIA ONLY

(New Zealand refer to EPCON™ C6 PLUS range)

GENERAL INFORMATION

Performance Related	Material Specification	Installation Related

Product

ChemSet™ Reo 502™ PLUS is a heavy duty pure Epoxy for anchoring threaded studs and reinforcing bar into cracked and uncracked concrete.



Compliance

European Technical Assessment (option 1) - ETA-18/0675

Design according to:

- AS5216 (formerly TS101)
- EN1992-4 (formerly ETAG001 Annex C, E & TR045)
- Use enclosed data for simplified calculation method

Use Ramset™ iExpert Anchor Software for optimised calculation or where a greater range of anchor layout detail is needed.

Benefits, Advantages and Features

- 100 year working Life

Greater productivity:

- Anchors in dry, damp, wet or flooded holes
- Easy dispensing even in cold weather

Greater security:

- Strong bond
- Rated for sustained loading

Versatile:

- Anchors in carbide drilled and diamond drilled holes*
- Cold and temperate climates

Greater safety:

- Low odour
- VOC Compliant
- Suitable for contact with drinking water



Principal Applications

- Threaded Studs
- Starter Bars
- Threaded Inserts
- Over-head installation
- Steel Columns
- Hand Rails
- Road Stitching

Recommended Installation Temperatures

	Minimum	Maximum
Substrate	5°C	40°C
Adhesive	10°C	40°C

Service Temperature Limits

-40°C to 70°C

Setting Times

Temperature of base material	Cartridge Temperature	Gel Time	Curing time in dry and wet concrete
5°C	Minimum 10°C	300 min	24 h
10°C	10°C	150 min	18 h
15°C	15°C	40 min	12 h
20°C	20°C	25 min	8 h
25°C	25°C	18 min	6 h
30°C	30°C	12 min	4 h
40°C	40°C	6 min	2 h

Note: Cartridge temperature minimum +10°C

Note

*Performance of cored & oversized holes was not included in the ETAG test program and therefore is based on testing conducted at Ramset™ Product Engineering Laboratory.

Installation

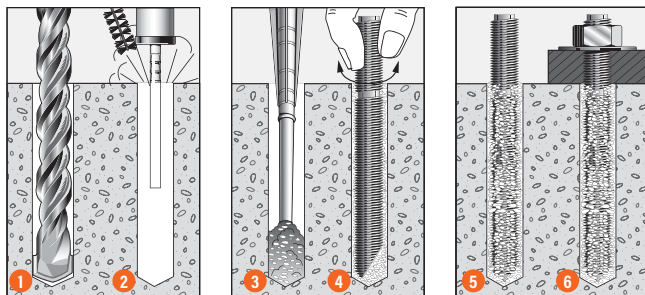

- Drill recommended diameter and depth hole.
- Important:** Use Ramset™ Dustless Drilling System to ensure holes are clean. Alternatively clean dust and debris from hole with stiff wire or nylon brush and blower in the following sequence: blow x 2, brush x 2, blow x 2, brush x 2, blow x 2.
- Screw mixing nozzle onto cartridge and dispense adhesive to waste until colour is uniform light grey (2-3 trigger pulls). Insert mixing nozzle to bottom of hole. Fill hole to 3/4 the hole depth slowly, ensuring no air pockets form.
- Insert Ramset™ ChemSet™ Anchor Stud/rebar to bottom of hole while turning.
- Allow ChemSet™ Reo 502™ PLUS to cure as per setting times.
- Attach fixture.

ChemSet™ Reo 502™ PLUS

CHEMICAL INJECTION - NON-CRACKED & CRACKED CONCRETE

AVAILABLE IN AUSTRALIA ONLY

Installation and performance details: ChemSet™ Reo 502™ PLUS and ChemSet™ Anchor Studs

Anchor size, d _b (mm)	Installation Details				Optimum dimensions*		
	Drilled hole diameter, d _h (mm)	Fixture hole diameter, d _f (mm)	Anchor effective depth, h (mm)	Tightening torque, T _r (Nm)	Edge distance, e _c (mm)	Anchor spacing, a _c (mm)	Concrete substrate thickness, b _m (mm)
M10	12	12	90	20	135	270	120
M12	14	14	110	40	165	330	140
M16	18	18	125	80	187.5	375	160
M20	22	22	150	120	225	450	190
			170		255	510	220
M24	26	26	160	160	240	480	200
			210		315	630	270
M30	35	33	280	200	420	840	350

* Note: For shear loads acting towards an edge or where these optimum dimensions are not achievable, please use the simplified strength limit state design process to verify capacity.

Anchor size, d _b (mm)	Reduced Characteristic Capacity#								
	Grade 5.8 Steel Studs		Grade 8.8 Steel Studs		ANSI 316 Stainless Steel Studs		Non-Cracked Concrete		
	Shear, φV _{us} (kN)	Tension, φN _{us} (kN)***	Shear, φV _{us} (kN)	Tension, φN _{us} (kN)***	Shear, φV _{us} (kN)	Tension, φN _{us} (kN)***	Tension, φN _{uc} (kN)**		
							Concrete Compressive Strength, f' _c		
	20 MPa			32 MPa			40 MPa		
M10	11.8	18.9	17.5	28.2	14.2	19.8	28.0	29.4	30.3
M12	17.5	28.1	26.0	41.9	21.1	29.5	37.8	43.1	44.4
M16	33.1	53.9	50.9	82.1	41.4	57.7	45.8	52.3	53.8
M20	49.9	81.3	76.8	123.9	62.4	87.1	60.2	76.2	80.7
							72.6	88.9	91.4
M24	72.3	117.8	111.3	179.5	90.4	126.2	66.3	84.0	94.0
							99.7	126.2	135.5
M30	-	-	185.5	299.2	-	-	153.5	173.8	178.8

**Note: Reduced characteristic ultimate concrete tensile capacity = φN_{uc} where φ = 0.67 and N_{uc} = Characteristic ultimate concrete tensile capacity.

For conversion to Working Load Limit MULTIPLY φN_{uc} x 0.5

***Note: Reduced characteristic ultimate steel tensile capacity = φN_{us} where φ = 0.67 and N_{us} = Characteristic ultimate steel tensile capacity.

For conversion to Working Load Limit MULTIPLY φN_{us} x 0.67 for Gr 5.8 & Gr 8.8

#Note: Design Tensile Capacity φN_{ur} = minimum of φN_{uc} and φN_{us}

For Cracked Concrete performance, please use the simplified strength limit state design process to verify capacity.

Data is based on a Service temperature limit of -40°C to +70°C

All data relevant for Dry, Wet and Flooded Holes.

For optimised performance data, please use Ramset iExpert Anchoring Software.

DESCRIPTION AND PART NUMBERS

Description	Cartridge Size	Part No.
ChemSet Reo 502 PLUS	600ml	RE0502P600

ENGINEERING PROPERTIES

ChemSet™ Anchor Studs and Threaded Rod

Anchor Size, d _b	Grade 8.8 Threaded Rod				Stainless Steel High Corrosion Resistance HCR Grade 1.4529/1.4565 Threaded Rod				Section modulus Z (mm ³)
	Shank diameter, d _s (mm)	Stressed Area (mm ²)	Yield Strength f _y MPa	UTS f _u MPa	Shank diameter, d _s (mm)	Stressed Area (mm ²)	Yield Strength f _y MPa	UTS f _u MPa	
M10	8.6	58	640	800	8.2	52.8	450	650	62.3
M12	10.4	84.3	640	800	10	78.5	450	650	109.2
M16	14.1	157	640	800	14	153.9	450	650	277.5
M20	17.7	245	640	800	17.2	232.4	450	650	540.9
M24	21.2	353	640	800	20.7	336.5	450	650	935.5
M30	26.7	561	640	800	-	-	-	-	-

Refer to "Engineering Properties" for ChemSet™ Anchor Studs Grade 5.8 and AISI 316 Stainless Steel in the SARB ANZ on page 141.

Chemical Anchoring - Anchor Studs

ChemSet™ Reo 502™ PLUS

STRENGTH LIMIT STATE DESIGN

AVAILABLE IN AUSTRALIA ONLY

Chemical Anchoring - Anchor Studs

STEP 1 Select anchor to be evaluated

Table 1a Indicative combined loading - interaction diagram

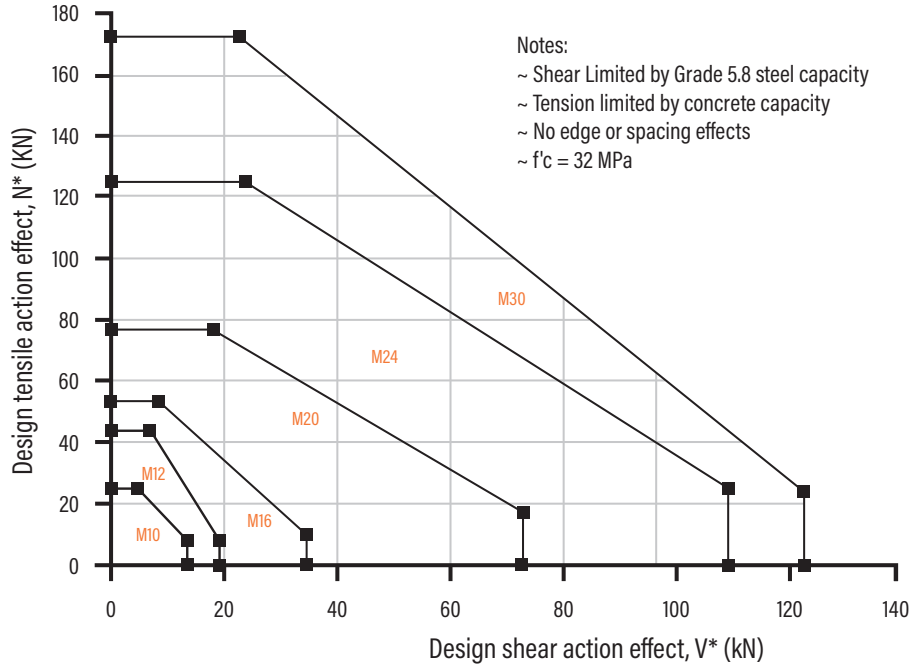

Table 1b Absolute minimum edge distance and anchor spacing values, e_m and a_m (mm)

Anchor size, d , M10	M10	M12	M16	M20	M24	M30
Min. Anchor Spacing - a_m	40	40	40	50	50	60
Min. Edge Distance - e_m	40	40	40	50	50	60

Step 1c Calculate anchor effective depth, h (mm)

Refer to "Description and Part Numbers" table for ChemSet Anchor Studs page in the SARB ANZ on page 141.

Effective depth, h (mm)

Preferred $h = h_n$ otherwise,

$h = L_e - t$

t = total thickness of material(s) being fastened.

Substrate thickness, b_m (mm)		
Anchor Stud Size (mm)		
M10	M12	M16 to M30
$h + 30\text{mm} \geq 100\text{mm}$		$h + (2 \times d_h)$

Checkpoint 1 Anchor size determined, absolute minima compliance achieved, effective depth (h) calculated.

ChemSet™ Reo 502™ PLUS

STRENGTH LIMIT STATE DESIGN

AVAILABLE IN AUSTRALIA ONLY

STEP 2 Verify concrete tensile capacity - per anchor

Table 2a Reduced characteristic ultimate concrete tensile capacity, ϕN_{uc} (kN), $\phi_c = 1/1.5 = 0.67$, $f'_c = 32$ MPa

Anchor Size, d_b	Combined pull-out and concrete cone resistance - ϕN_{ucp}						Concrete Cone Resistance - ϕN_{ucc}
	M10	M12	M16	M20	M24	M30	
Drilled Hole Dia, d_h (mm)	12	14	18	22	26	35	
Effective Depth, h (mm)							
70	22.9						24.3
80	26.1						29.7
90	29.4	35.3					35.4
100	32.7	39.2					41.5
110	35.9	43.1	46.0				47.9
120	39.2	47.0	50.2				54.5
125	40.8	49.0	52.3				58.0
140	45.7	54.9	58.5				68.7
150	49.0	58.8	62.7	78.4			76.2
160	52.3	62.7	66.9	83.6	100.4		84.0
170	55.5	66.7	71.1	88.9	106.6		91.9
180	58.8	70.6	75.3	94.1	112.9		100.2
190	62.1	74.5	79.5	99.3	119.2		108.6
200	65.3	78.4	83.6	104.6	125.5		117.3
210		82.3	87.8	109.8	131.7	130.4	126.2
240		94.1	100.4	125.5	150.6	149.0	154.2
280			117.1	146.4	175.6	173.8	194.4
320			133.8	167.3	200.7	198.6	237.5
350				183.0	219.6	217.3	271.6
400				209.1	250.9	248.3	331.9
450					282.3	279.4	396.0
480					301.1	298.0	436.3
550						341.4	535.1
600						372.5	609.7

For optimised performance data, please use Ramset iExpert Anchoring Software.

Table 2a-2 Cracked Concrete effect, tension, X_{ncr}

Anchor Size, d_b	Cracked Concrete Effect - X_{ncr}						X_{ncr}
	where $\phi N_{uc} = \phi N_{ucp}$ (from Table 2a)						
f'_c (MPa)	M10	M12	M16	M20	M24	M30	where $\phi N_{uc} = \phi N_{ucc}$ (from Table 2a)
20 to 50	0.67	0.67	0.79	0.75	0.75	0.63	0.70

Bold values are at Chemset Anchor Stud nominal Depths

For Sustained Loads MULTIPLY ϕN_{uc} x 0.6 (100 years) or ϕN_{uc} x 0.72 (50 years)

All data relevant for Dry, Wet and Flooded Holes

For Non-cracked concrete $X_{ncr} = 1$.

Calculate ϕN_{urc} for both ϕN_{ucp} and ϕN_{ucc} then choose the minimum - Refer to Checkpoint 2

Table 2b-1 Concrete service temperature limits effect, tension, X_{ns}

Anchor Size, d_b	Service temperature limits effect, tension, X_{ns}						X_{ns}
	M10	M12	M16	M20	M24	M30	
Service temperature (°C)							where $\phi N_{uc} = \phi N_{ucc}$ (from Table 2a)
-40 °C to +70 °C				1.00			1.00

Table 2b-2 Concrete compressive strength effect, tension, X_{nc}

Anchor Size, d_b	Cracked & Non-Cracked Concrete - X_{nc}						X_{nc}
	where $\phi N_{uc} = \phi N_{ucp}$ (from Table 2a)						
f'_c (MPa)	M10	M12	M16	M20	M24	M30	where $\phi N_{uc} = \phi N_{ucc}$ (from Table 2a)
20	0.96	0.96	0.96	0.96	0.96	0.96	0.79
25	0.98	0.98	0.98	0.98	0.98	0.98	0.88
32	1.00	1.00	1.00	1.00	1.00	1.00	1.00
40	1.03	1.03	1.03	1.03	1.03	1.03	1.12
50	1.05	1.05	1.05	1.05	1.05	1.05	1.25

Chemical Anchoring - Anchor Studs

ChemSet™ Reo 502™ PLUS

STRENGTH LIMIT STATE DESIGN

AVAILABLE IN AUSTRALIA ONLY

Chemical Anchoring - Anchor Studs

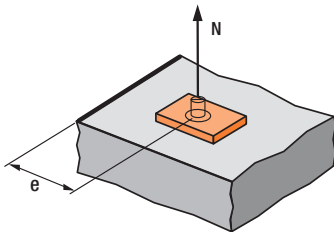

$$X_{ne} = 0.25 + 0.5*(e/h)$$

Where $e_m \leq e \leq e_c$

$$e_c = 1.5*h$$

Note: Tabled values are based on the nominal effective depth, h shown in the installation details. For other values of X_{ne} , please use equation shown above.

Table 2c - Concrete Edge distance effect, tension, X_{ne}

Anchor size, d_b	M10	M12	M16	M20	M24	M30
Edge distance, e (mm)						
40	0.47	0.43	0.41			
45	0.50	0.45	0.43			
50	0.53	0.48	0.45	0.40	0.36	
55	0.56	0.50	0.47	0.41	0.38	
65	0.61	0.55	0.51	0.44	0.40	0.37
70	0.64	0.57	0.53	0.46	0.42	0.38
80	0.69	0.61	0.57	0.49	0.44	0.39
100	0.81	0.70	0.65	0.54	0.49	0.43
115	0.89	0.77	0.71	0.59	0.52	0.46
135	1	0.86	0.79	0.65	0.57	0.49
165		1	0.91	0.74	0.64	0.54
187			1	0.80	0.70	0.58
255				1	0.86	0.71
315					1	0.81
420						1

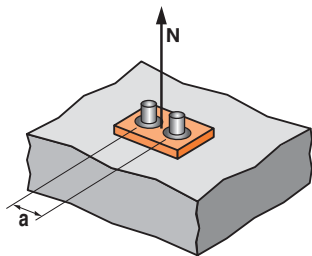

$$X_{na} = 0.5 + a/(6*h)$$

Where $a_m \leq a \leq a_c$

$$a_c = 3*h$$

Note: Tabled values are based on the nominal effective depth, h shown in the installation details. For other values X_{na} , please use equation shown above.

Table 2d - Concrete anchor spacing effect, tension, X_{na}

Anchor size, d_b	M10	M12	M16	M20	M24	M30
Anchor spacing, a (mm)						
40	0.57	0.56	0.55			
45	0.58	0.57	0.56			
50	0.59	0.58	0.57	0.55	0.53	
55	0.60	0.58	0.57	0.55	0.54	
65	0.62	0.60	0.59	0.56	0.55	0.54
85	0.66	0.63	0.61	0.58	0.57	0.55
100	0.69	0.65	0.63	0.60	0.58	0.56
125	0.73	0.69	0.67	0.62	0.60	0.57
150	0.78	0.73	0.70	0.65	0.62	0.59
200	0.87	0.80	0.77	0.70	0.66	0.62
270	1	0.91	0.86	0.76	0.71	0.66
330		1	0.94	0.82	0.76	0.70
375			1	0.87	0.80	0.72
510				1	0.90	0.80
630					1	0.88
840						1

Checkpoint 2

Design reduced ultimate concrete tensile capacity, ϕN_{urc}

$$\phi N_{urc} = \text{minimum of } \phi N_{ucp} * X_{ncr} * X_{ns} * X_{nc} * X_{ne} * X_{na} \text{ and } \phi N_{ucc} * X_{ncr} * X_{ns} * X_{nc} * X_{ne} * X_{na}$$

STEP 3

Verify anchor tensile capacity - per anchor

Table 3a Reduced characteristic ultimate steel tensile capacity, ϕN_{us} (kN) where $\phi_n = 0.67$ for Gr 5.8 & Gr 8.8

Anchor size, d_b	M10	M12	M16	M20	M24	M30
ChemSet™ Anchor Stud Grade 5.8 Carbon Steel	18.9	28.1	53.9	81.3	117.8	-
ChemSet™ Anchor Stud A4/316 Stainless Steel	19.8	29.5	57.7	87.1	126.2	-
ChemSet™ Anchor Stud Grade 8.8 Carbon Steel	28.2	41.9	82.1	123.9	179.5	299.2

Note: $\phi_n = 0.58$ for ChemSet™ Anchor Stud A4/316 Stainless Steel

Checkpoint 3

Design reduced ultimate tensile capacity, ϕN_{ur}

$$\phi N_{ur} = \text{minimum of } \phi N_{urc} \text{ and } \phi N_{us}$$

Check $N^*/\phi N_{ur} \leq 1.0$,

if not satisfied return to step 1

ChemSet™ Reo 502™ PLUS

STRENGTH LIMIT STATE DESIGN

AVAILABLE IN AUSTRALIA ONLY

Chemical Anchoring - Anchor Studs

STEP 4

Step 4 - Verify concrete shear capacity - per anchor

Table 4a Reduced characteristic ultimate concrete edge shear capacity, ϕV_{uc} (kN), $\phi = 1/1.5 = 0.67$, $f'_c = 32$ MPa

Anchor size, d_b	M10	M12	M16	M20	M24	M30
Effective depth, h (mm)	70 - 200	90 - 240	110 - 320	150 - 400	160 - 480	210 - 600
Edge distance, e_m						
40	4.3	4.7	5.4			
50				8.2	8.8	
60						12.7

For optimised performance data, please use Ramset iExpert Anchoring Software.

Table 4a-2 Cracked Concrete effect, shear, X_{vcr}

Anchor size, d_b	M10	M12	M16	M20	M24	M30
X_{vcr}	0.70					

For Non-cracked concrete $X_{vcr} = 1.0$

Table 4b - Concrete compressive strength effect, shear, X_{vc}

f'_c (MPa)	20	25	32	40	50
X_{vc}	0.79	0.86	1	1.11	1.22

Table 4c - Concrete load direction effect, concrete edge shear, X_{vd}

Angle, α°	0-55	60	70	80	90-180
X_{vd}	1	1.1	1.2	1.5	2

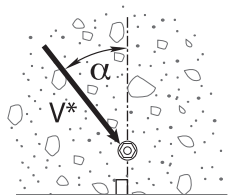

Load direction effect, conc. edge shear, X_{vd}

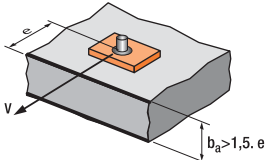

$$X_{ve} = e/e_m * \sqrt{e/e_m}$$

Table 4d - Concrete anchor spacing and edge distance effect, concrete edge shear, X_{ve}

For single anchor fastening X_{ve}

e/e_m	1.0	1.2	1.4	1.6	1.8	2.0	2.2	2.4	2.6	2.8	3.0	3.2
X_{ve}	1.00	1.31	1.66	2.02	2.41	2.83	3.26	3.72	4.19	4.69	5.20	5.72

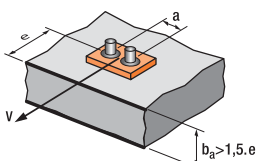

$$X_{ve} = \frac{3 * e + a}{6 * e_m} * \sqrt{e/e_m}$$

For 2 anchors fastening X_{ve}

e/e_m	1.0	1.2	1.4	1.6	1.8	2.0	2.2	2.4	2.6	2.8	3.0	3.2
a/e_m												
1.0	0.67	0.84	1.03	1.22	1.43	1.65	1.88	2.12	2.36	2.62	2.89	3.16
1.5	0.75	0.93	1.12	1.33	1.54	1.77	2.00	2.25	2.50	2.76	3.03	3.31
2.0	0.83	1.02	1.22	1.43	1.65	1.89	2.12	2.38	2.63	2.90	3.18	3.46
2.5	0.92	1.11	1.32	1.54	1.77	2.00	2.25	2.50	2.77	3.04	3.32	3.61
3.0	1.00	1.20	1.42	1.64	1.88	2.12	2.37	2.63	2.90	3.18	3.46	3.76
3.5		1.30	1.52	1.75	1.99	2.24	2.50	2.76	3.04	3.32	3.61	3.91
4.0			1.62	1.86	2.10	2.36	2.62	2.89	3.17	3.46	3.75	4.05
4.5				1.96	2.21	2.47	2.74	3.02	3.31	3.60	3.90	4.20
5.0					2.33	2.59	2.87	3.15	3.44	3.74	4.04	4.35
5.5						2.71	2.99	3.28	3.71	4.02	4.33	4.65
6.0							2.83	3.11	3.41	3.71	4.02	4.33

For 3 anchors fastening and more

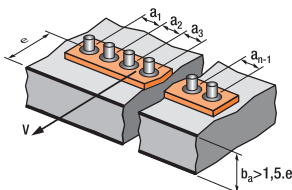

$$X_{ve} = \frac{3 * e + a_1 + a_2 + a_3 + \dots + a_{n-1}}{3 * n * e_m} * \sqrt{e/e_m}$$

ChemSet™ Reo 502™ PLUS

STRENGTH LIMIT STATE DESIGN

AVAILABLE IN AUSTRALIA ONLY

Chemical Anchoring - Anchor Studs

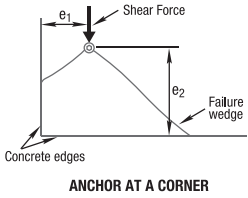

Table 4e Reduced characteristic ultimate concrete pryout capacity, ϕV_{ucp} (kN), $\phi = 1/1.5 = 0.67$, $f'_c = 32$ MPa

Anchor size, d_b	M10	M12	M16	M20	M24	M30
Effective depth, h (mm)	90	110	125	170	210	280
-40 °C to +70 °C	58.8	86.3	104.6	177.7	263.5	335.2

Table 4f Anchor at a corner effect, concrete edge shear, X_{vs}

Note: For $e_1/e_2 > 1.25$, $X_{vs} = 1.0$

Edge distance, e_2 (mm)	25	30	35	50	60	75	125	200	300	400	600	900
Edge distance, e_1 (mm)												
25	0.86	0.77	0.70	0.58	0.53	0.49	0.41	0.37	0.35	0.34	0.32	0.32
30	0.97	0.86	0.78	0.64	0.58	0.52	0.43	0.38	0.36	0.34	0.33	0.32
35	1.00	0.95	0.86	0.69	0.63	0.56	0.46	0.40	0.37	0.35	0.33	0.32
50	1.00	1.00	1.00	0.86	0.77	0.67	0.52	0.44	0.39	0.37	0.35	0.33
60	1.00	1.00	1.00	0.97	0.86	0.75	0.57	0.47	0.41	0.38	0.36	0.34
75	1.00	1.00	1.00	1.00	1.00	0.86	0.64	0.51	0.44	0.41	0.37	0.35
125	1.00	1.00	1.00	1.00	1.00	1.00	0.86	0.65	0.53	0.48	0.42	0.38
200	1.00	1.00	1.00	1.00	1.00	1.00	1.00	0.86	0.67	0.58	0.49	0.42
300	1.00	1.00	1.00	1.00	1.00	1.00	1.00	1.00	0.86	0.72	0.58	0.49
400	1.00	1.00	1.00	1.00	1.00	1.00	1.00	1.00	1.00	0.86	0.67	0.55
500	1.00	1.00	1.00	1.00	1.00	1.00	1.00	1.00	1.00	1.00	0.77	0.61
600	1.00	1.00	1.00	1.00	1.00	1.00	1.00	1.00	1.00	1.00	0.86	0.67
900	1.00	1.00	1.00	1.00	1.00	1.00	1.00	1.00	1.00	1.00	1.00	0.86

Checkpoint **4a**

Design reduced ultimate concrete edge shear capacity, ϕV_{urc}
 $\phi V_{urc} = \phi V_{uc} * X_{vcr} * X_{vc} * X_{vd} * X_{ve} * X_{vs}$

Checkpoint **4b**

Design reduced ultimate concrete pryout capacity, ϕV_{urcp}
 $\phi V_{urcp} = \phi V_{ucp} * X_{ncr} * X_{nc} * X_{ne} * X_{na}$

STEP **5**

Verify anchor shear capacity - per anchor

Table 5a Reduced characteristic ultimate steel shear capacity, ϕV_{us} (kN) where $\phi_v = 0.67$

Anchor size, d_b	M10	M12	M16	M20	M24	M30
ChemSet™ Anchor Stud Grade 5.8 Carbon Steel	11.8	17.5	33.1	49.9	72.3	-
ChemSet™ Anchor Stud A4/316 Stainless Steel	14.2	21.1	41.4	62.4	90.4	-
ChemSet™ Anchor Stud Grade 8.8 Carbon Steel	17.5	26.0	50.9	76.8	111.3	185.5

Checkpoint **5**

Design reduced ultimate shear capacity, ϕV_{ur}
 $\phi V_{ur} = \text{minimum of } \phi V_{urcr} \phi V_{urcp} \phi V_{us}$
 Check $V^*/\phi V_{ur} \leq 1.0$,
 if not satisfied return to step 1

ChemSet™ Reo 502™ PLUS

STRENGTH LIMIT STATE DESIGN

AVAILABLE IN AUSTRALIA ONLY

STEP 6 Combined Loading

Checkpoint 6

Check
 $N^*/\phi N_{ur} + V^*/\phi V_{ur} \leq 1.2$,
 if not satisfied return to step 1

Specify - Threaded Stud Anchors
 Ramset™ ChemSet™ Reo 502™ PLUS with
 (Anchor Size) grade 5.8 ChemSet™ Anchor
 Stud (Anchor Stud Part Number) Drilled
 Hole Depth to be (h) mm.

Example
 Ramset™ ChemSet™ Reo 502™ PLUS
 Injection with M16 grade 5.8 ChemSet™
 Anchor Stud (CS16190GH). Drilled hole depth
 to be 125mm. To be installed according to
 Ramset™ Installation Instructions.

Ramset™ iExpert Anchor Software for optimised calculation or where a greater range of anchor layout detail is needed.

EPCON™ C8 Xtrem™

CHEMICAL INJECTION - NON-CRACKED & CRACKED CONCRETE

[Back to index](#)

GENERAL INFORMATION

Performance Related	Material Specification	Installation Related

Product

EPCON™ C8 Xtrem™ is a High Performance Pure Epoxy Anchoring adhesive for use in Cracked and Non-Cracked concrete. For structures subject to external exposure, permanently damp or aggressive conditions.



Compliance

European Technical Assessment (option 1) - ETA-10/0309

Design according to:

- AS5216 (formerly TS101)
- EN1992-4 (formerly ETAG001 Annex C, E & TR045)
- Use enclosed data for simplified calculation method

Use Ramset™ iExpert Anchor Software for optimised calculation or where a greater range of anchor layout detail is needed.



Benefits, Advantages and Features

- 50 year working life

Greater productivity:

- Anchors in dry, damp, wet or flooded holes
- No weather delays
- Fast, easy dispensing with high flow mixer

Greater security:

- Highest performance in cracked concrete
- Rated for sustained loading

Versatile

- Anchors all stud & bar diameters in all directions
- Oversized holes*
- Anchors in carbide drilled and diamond cored holes*
- For tropical and Cold weather conditions

Greater safety:

- Low odour

Fire Rated : Refer Fire rated anchoring section

Installation

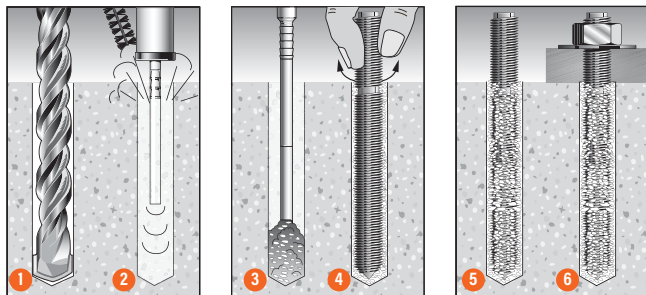

- Drill recommended diameter and depth hole.
- Important:** Use Ramset™ Dustless Drilling System to ensure holes are clean. Alternatively, clean dust and debris from hole with stiff wire or nylon brush and blower in the following sequence: blow x2, brush x2, blow x2, brush x2, blow x2.
- Screw mixing nozzle onto cartridge and dispense adhesive to waste until colour is uniform light grey (2-3 trigger pulls).
Insert mixing nozzle to bottom of hole.
Fill hole to 3/4 the hole depth slowly, ensuring no air pockets form.
- Insert Ramset™ ChemSet™ Anchor Stud/rebar to bottom of hole while turning.
- Allow EPCON™ C8 Xtrem™ to cure as per setting times.
- Attach fixture.

Principal Applications

- Anchoring into cracked & non cracked concrete
- Road barrier hold down bolts
- Bridge refurbishment
- Road & Rail tunnel construction
- Reinforcing bar from 10 to 32mm
- Starter Bars
- Threaded Studs from M8 to M30
- Threaded Stud material: Zn, A4 316, HCR steels
- Threaded Stud material: 5.8, 8.8, 10.9 grade

Recommended Installation Temperatures

	Minimum	Maximum
Substrate	5°C	40°C
Adhesive	5°C	40°C

Load should not be applied to anchor until the chemical has sufficiently cured as specified.

Service Temperature Limits

-40°C to 80°C

Setting Times EPCON™ C8 Xtrem™

Temperature of base material	Gel Time	Curing time in dry concrete	Curing time in wet concrete
5°C - 9°C	20 min	30 h	60 h
10°C - 19°C	14 min	23 h	46 h
20°C - 24°C	11 min	16 h	32 h
25°C - 29°C	8 min	12 h	24 h
30°C - 39°C	5 min	8 h	16 h
40°C	5 min	6 h	12 h

Note

*Performance of cored & oversized holes was not included in the ETAG test program and therefore is based on testing conducted at Ramset™ Product Engineering Laboratory.

EPCON™ C8 Xtrem™

CHEMICAL INJECTION - NON-CRACKED & CRACKED CONCRETE

Installation and performance details: EPCON™ C8 Xtrem™ and ChemSet™ Anchor Studs

Anchor size, d _b (mm)	Installation Details				Optimum dimensions*		
	Drilled hole diameter, d _h (mm)	Fixture hole diameter, d _f (mm)	Anchor effective depth, h (mm)	Tightening torque, T _r (Nm)	Edge distance, e _c (mm)	Anchor spacing, a _c (mm)	Concrete substrate thickness, b _m (mm)
M10	12	12	90	20	135	270	120
M12	14	14	110	30	165	330	140
M16	18	18	125	60	187.5	375	160
M20	25	22	150	120	225	450	190
			170		255		220
M24	28	26	160	200	240	480	200
			210		315		270
M30	35	33	280	400	420	840	350

* Note: For shear loads acting towards an edge or where these optimum dimensions are not achievable, please use the simplified strength limit state design process to verify capacity.

Anchor size, d _b (mm)	Reduced Characteristic Capacity#								
	Grade 5.8 Steel Studs		Grade 8.8 Steel Studs		ANSI 316 Stainless Steel Studs		Non-Cracked Concrete		
	Shear, φV _{us} (kN)	Tension, φN _{us} (kN)***	Shear, φV _{us} (kN)	Tension, φN _{us} (kN)***	Shear, φV _{us} (kN)	Tension, φN _{us} (kN)***	Tension, φN _{uc} (kN)**		
							Concrete Compressive Strength, f' _c		
						20 MPa	32 MPa	40 MPa	
M10	11.8	18.9	17.5	28.2	14.2	19.8	25.1	26.6	28.1
M12	17.5	28.1	26.0	41.9	21.1	29.5	36.9	39.4	41.7
M16	33.1	53.9	50.9	82.1	41.4	57.7	38.2	48.3	53.6
M20	49.9	81.3	76.8	123.9	62.4	87.1	50.2	63.5	70.5
							60.5	76.6	85.1
M24	72.3	117.8	111.3	179.5	90.4	126.2	55.3	70.0	77.7
							83.1	105.2	116.8
M30	-	-	185.5	299.2	-	-	128.0	162.0	179.8

**Note: Reduced characteristic ultimate concrete tensile capacity = φN_{uc} where φ = 0.56 and N_{uc} = Characteristic ultimate concrete tensile capacity.

For conversion to Working Load Limit MULTIPLY φN_{uc} x 0.6

***Note: Reduced characteristic ultimate steel tensile capacity = φN_{us} where φ = 0.67 and N_{us} = Characteristic ultimate steel tensile capacity.

For conversion to Working Load Limit MULTIPLY φN_{us} x 0.67 for Gr 5.8 & Gr 8.8

#Note: Design Tensile Capacity φN_{ur} = minimum of φN_{uc} and φN_{us}

For Cracked Concrete performance, please use the simplified strength limit state design process to verify capacity.

Data is based on a Service temperature limit of -40°C to +40°C

FLOODED HOLES: Multiply φN_{uc} x 0.69.

For optimised performance data, please use Ramset iExpert Anchoring Software.

DESCRIPTION AND PART NUMBERS

Description	Cartridge Size	Part No.
EPCON™ C8 Xtrem™	450ml	C8-450

Drilled hole depth, h₁ (mm)
 h₁ = h
 h = Effective depth

ENGINEERING PROPERTIES

ChemSet™ Anchor Studs and Threaded Rod

Anchor Size, d _b	Grade 8.8 Threaded Rod				Stainless Steel High Corrosion Resistance HCR Grade 1.4529/1.4565 Threaded Rod				Section modulus Z (mm ³)
	Shank diameter, d _s (mm)	Stressed Area (mm ²)	Yield Strength f _y MPa	UTS f _t MPa	Shank diameter, d _s (mm)	Stressed Area (mm ²)	Yield Strength f _y MPa	UTS f _t MPa	
M10	8.6	58	640	800	8.2	52.8	450	650	62.3
M12	10.4	84.3	640	800	10	78.5	450	650	109.2
M16	14.1	157	640	800	14	153.9	450	650	277.5
M20	17.7	245	640	800	17.2	232.4	450	650	540.9
M24	21.2	353	640	800	20.7	336.5	450	650	935.5
M30	26.7	561	640	800	-	-	-	-	-

Refer to "Engineering Properties" for ChemSet™ Anchor Studs Grade 5.8 and AISI 316 Stainless Steel in the SARB ANZ on page 141.

EPCON™ C8 Xtrem™

STRENGTH LIMIT STATE DESIGN

STEP 1 Select anchor to be evaluated

Table 1a - Indicative combined loading - interaction diagram

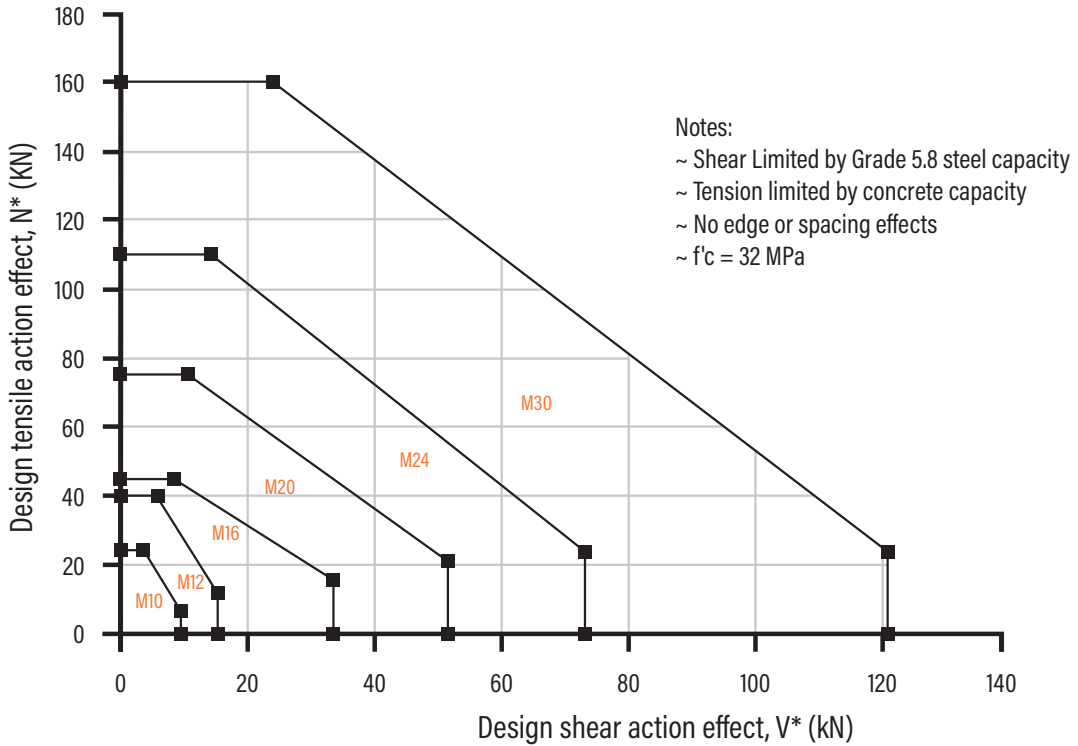

Table 1b - Absolute minimum edge distance and anchor spacing values, e_m and a_m (mm) for cracked concrete

Anchor size, d _b	M10	M12	M16	M20	M24	M30
Min. Anchor spacing - a _m	50	60	80	100	120	150
Min. Edge Distance - e _m	50	60	80	100	120	150

Step 1c Calculate anchor effective depth, h (mm)

Refer to "Description and Part Numbers" table for ChemSet Anchor Studs in the SARB ANZ on page 141.

Effective depth, h (mm)

Preferred $h = h_n$ otherwise,

$h = L_e - t$

t = total thickness of material(s) being fastened.

Substrate thickness b _m (mm)		
Anchor Stud Size (mm)		
M10	M12	M16 to M30
h + 30mm ≥ 100mm		h + (2 x d _b)

Checkpoint 1 Anchor size determined, absolute minima compliance achieved, effective depth (h) calculated.

EPCON™ C8 Xtrem™

STRENGTH LIMIT STATE DESIGN

STEP 2 Verify concrete tensile capacity - per anchor

Table 2a Reduced characteristic ultimate concrete tensile capacity, ϕN_{uc} (kN), $\phi_c = 1/1.8 = 0.56$, $f'_c = 32$ MPa

Anchor Size, d_b	Combined pull-out and concrete cone resistance - ϕN_{ucp}						Concrete Cone Resistance - ϕN_{ucc}
	M10	M12	M16	M20	M24	M30	
Drilled Hole Dia, d_h (mm)	12	14	18	25	28	35	
Effective Depth, h (mm)							
70	20.7						20.2
80	23.7						24.7
90	26.6	32.3					29.5
100	29.6	35.9					34.6
110	32.6	39.4	50.2				39.9
120	35.5	43.0	54.8				45.4
125	37.0	44.8	57.1				48.3
140	41.4	50.2	63.9				57.3
150	44.4	53.8	68.5	81.4			63.5
160	47.4	57.4	73.1	86.8	98.5		70.0
170	50.3	61.0	77.6	92.2	104.6		76.6
180	53.3	64.5	82.2	97.6	110.8		83.5
190	56.2	68.1	86.7	103.1	116.9		90.5
200	59.2	71.7	91.3	108.5	123.1		97.8
210		75.3	95.9	113.9	129.2	165.8	105.2
240		86.1	109.6	130.2	147.7	189.5	128.5
280			127.8	151.9	172.3	221.1	162.0
320			146.1	173.6	196.9	252.7	197.9
350				189.9	215.4	276.4	226.4
400				217.0	246.1	315.8	276.6
450					276.9	355.3	330.0
480					295.4	379.0	363.5
550						434.3	445.9
600						473.8	508.1

For optimised performance data, please use Ramset iExpert Anchoring Software.

Table 2a-2 Cracked Concrete effect, tension, X_{ncr}

Anchor Size, d_b	Cracked Concrete Effect - X_{ncr}						X_{ncr}
	M10	M12	M16	M20	M24	M30	
f'_c (MPa)	where $\phi N_{uc} = \phi N_{ucp}$ (from Table 2a)						where $\phi N_{uc} = \phi N_{ucc}$ (from Table 2a)
20 to 50	0.59	0.55	0.52	0.56	0.60	0.53	0.70

Bold values are at Chemset Anchor Stud nominal Depths

For Sustained Loads MULTIPLY $\phi N_{uc} \times 0.6$ FLOODED HOLES: Multiply $\phi N_{uc} \times 0.69$ For Non-cracked concrete $X_{ncr} = 1$

If Service temperature limit is -40°C to +40°C then Refer to Checkpoint 2	If Service temperature limit is -40°C to +80°C then $\phi N_{uc} = \phi N_{ucp}$
---	--

Table 2b-1 Concrete service temperature limits effect, tension, X_{ns}

Anchor Size, d_b	Service temperature limits effect, tension, X_{ns}						X_{ns}
	M10	M12	M16	M20	M24	M30	
Service temperature (°C)	where $\phi N_{uc} = \phi N_{ucp}$ (from Table 2a)						where $\phi N_{uc} = \phi N_{ucc}$ (from Table 2a)
-40 °C to +40 °C	1.00	1.00	1.00	1.00	1.00	1.00	1.00
-40 °C to +80 °C	0.56	0.55	0.52	0.52	0.52	0.53	1.00

Table 2b-2 Concrete compressive strength effect, tension, X_{nc}

Anchor Size, d_b	Non-Cracked Concrete - X_{nc}						X_{nc}
	M10	M12	M16	M20	M24	M30	
f'_c (MPa)	where $\phi N_{uc} = \phi N_{ucp}$ (from Table 2a)						where $\phi N_{uc} = \phi N_{ucc}$ (from Table 2a)
20	0.94	0.93	0.92	0.90	0.88	0.86	0.79
25	0.97	0.96	0.95	0.95	0.94	0.92	0.86
32	1.00	1.00	1.00	1.00	1.00	1.00	1.00
40	1.06	1.06	1.07	1.09	1.11	1.13	1.11
50	1.08	1.09	1.12	1.14	1.17	1.22	1.22

Anchor Size, d_b	Cracked Concrete - X_{nc}						X_{nc}
	M10	M12	M16	M20	M24	M30	
f'_c (MPa)	where $\phi N_{uc} = \phi N_{ucp}$ (from Table 2a)						where $\phi N_{uc} = \phi N_{ucc}$ (from Table 2a)
20	0.95	0.95	0.94	0.93	0.92	0.91	0.79
25	0.97	0.97	0.97	0.96	0.95	0.95	0.86
32	1.00	1.00	1.00	1.00	1.00	1.00	1.00
40	1.03	1.04	1.05	1.07	1.06	1.08	1.11
50	1.05	1.07	1.08	1.09	1.10	1.14	1.22

EPCON™ C8 Xtrem™

STRENGTH LIMIT STATE DESIGN

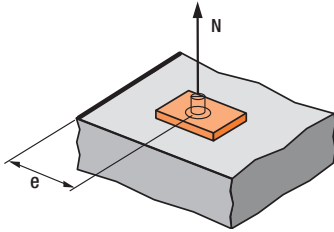

$$X_{ne} = 0.25 + 0.5 \cdot (e/h)$$

Where $e_m \leq e \leq e_c$

$$e_c = 1.5 \cdot h$$

Note: Tabled values are based on the nominal effective depth, h shown in the installation details. For other values of X_{ne} , please use equation shown above.

Table 2c - Concrete Edge distance effect, tension, X_{ne}

Anchor size, d_b	M10	M12	M16	M20	M24	M30
Edge distance, e (mm)						
50	0.53					
60	0.58	0.52				
80	0.69	0.61	0.57			
90	0.75	0.66	0.61			
100	0.81	0.70	0.65	0.54		
120	0.92	0.80	0.73	0.60	0.54	
135	1.00	0.86	0.79	0.65	0.57	
150		0.93	0.85	0.69	0.61	0.52
165		1.00	0.91	0.74	0.64	0.54
187			1.00	0.80	0.70	0.58
255				1.00	0.86	0.71
315					1.00	0.81
420						1.00

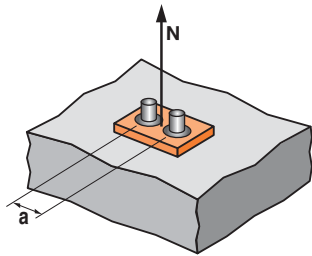

$$X_{na} = 0.5 + a/(6 \cdot h)$$

Where $a_m \leq a \leq a_c$

$$a_c = 3 \cdot h$$

Note: Tabled values are based on the nominal effective depth, h shown in the installation details. For other values X_{na} , please use equation shown above.

Table 2d - Concrete anchor spacing effect, tension, X_{na}

Anchor size, d_b	M10	M12	M16	M20	M24	M30
Anchor spacing, a (mm)						
50	0.59					
60	0.61	0.59				
80	0.65	0.62	0.61			
100	0.69	0.65	0.63	0.60		
120	0.72	0.68	0.66	0.62	0.60	
150	0.78	0.73	0.70	0.65	0.62	0.59
200	0.87	0.80	0.77	0.70	0.66	0.62
270	1.00	0.91	0.86	0.76	0.71	0.66
330		1.00	0.94	0.82	0.76	0.70
375			1.00	0.87	0.80	0.72
510				1.00	0.90	0.80
630					1.00	0.88
840						1.00

Checkpoint 2

Design reduced ultimate concrete tensile capacity, ϕN_{urc}

$$\phi N_{urc} = \phi N_{uc} * X_{ncr} * X_{ns} * X_{nc} * X_{ne} * X_{na}$$

If Service temperature limit is -40°C to +40°C then

$$\phi N_{urc} = \text{minimum of } \phi N_{ucp} * X_{ncr} * X_{ns} * X_{nc} * X_{ne} * X_{na} \text{ and } \phi N_{ucc} * X_{ncr} * X_{ns} * X_{nc} * X_{ne} * X_{na}$$

STEP 3

Verify anchor tensile capacity - per anchor

Table 3a Reduced characteristic ultimate steel tensile capacity, ϕN_{usr} (kN) where $\phi_n = 0.67$ for Gr 5.8 & Gr 8.8

Anchor size, d_b	M10	M12	M16	M20	M24	M30
ChemSet™ Anchor Stud Grade 5.8 Carbon Steel	18.9	28.1	53.9	81.3	117.8	-
ChemSet™ Anchor Stud A4/316 Stainless Steel	19.8	29.5	57.7	87.1	126.2	-
ChemSet™ Anchor Stud Grade 8.8 Carbon Steel	28.2	41.9	82.1	123.9	179.5	299.2

Note $\phi_n = 0.58$ for ChemSet™ Anchor Stud A4/316 Stainless Steel

Checkpoint 3

Design reduced ultimate tensile capacity, ϕN_{ur}

$$\phi N_{ur} = \text{minimum of } \phi N_{urc} \text{ and } \phi N_{usr}$$

Check $N^*/\phi N_{ur} \leq 1.0$, if not satisfied return to step 1

EPCON™ C8 Xtrem™

STRENGTH LIMIT STATE DESIGN

STEP 4

Step 4 - Verify concrete shear capacity - per anchor

Table 4a Reduced characteristic ultimate concrete edge shear capacity, $\phi V_{uc(kN)}, \phi = 1/1.5 = 0.67, f'_c = 32 \text{ MPa}$

Anchor size, d_b	M10	M12	M16	M20	M24	M30
Effective depth, h (mm)	70 - 200	90 - 240	110 - 320	150 - 400	160 - 480	210 - 600
Edge distance, e_m						
50	5.7					
60		7.9				
80			12.6			
100				18.8		
120					24.8	
150						36.6

For optimised performance data, please use Ramset iExpert Anchoring Software.

Table 4a-2 Cracked Concrete effect, shear, X_{vcr}

Anchor size, d_b	M10	M12	M16	M20	M24	M30
X_{vcr}	0.70					

For Non-cracked concrete $X_{vcr} = 1.0$

Table 4b - Concrete compressive strength effect, shear, X_{vc}

f'_c (MPa)	20	25	32	40	50
X_{vc}	0.79	0.86	1.0	1.11	1.22

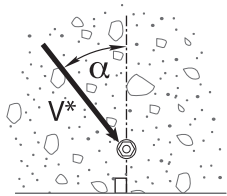

Load direction effect, conc. edge shear, X_{vld}

Table 4c - Concrete load direction effect, concrete edge shear, X_{vld}

Angle, α°	0-55	60	70	80	90-180
X_{vld}	1	1.1	1.2	1.5	2

Table 4d - Concrete anchor spacing and edge distance effect, concrete edge shear, X_{ve}

For single anchor fastening X_{ve}

e/e_m	1.0	1.2	1.4	1.6	1.8	2.0	2.2	2.4	2.6	2.8	3.0	3.2
X_{ve}	1.00	1.31	1.66	2.02	2.41	2.83	3.26	3.72	4.19	4.69	5.20	5.72

For 2 anchors fastening X_{ve}

e/e_m	1.0	1.2	1.4	1.6	1.8	2.0	2.2	2.4	2.6	2.8	3.0	3.2
a/e_m												
1.0	0.67	0.84	1.03	1.22	1.43	1.65	1.88	2.12	2.36	2.62	2.89	3.16
1.5	0.75	0.93	1.12	1.33	1.54	1.77	2.00	2.25	2.50	2.76	3.03	3.31
2.0	0.83	1.02	1.22	1.43	1.65	1.89	2.12	2.38	2.63	2.90	3.18	3.46
2.5	0.92	1.11	1.32	1.54	1.77	2.00	2.25	2.50	2.77	3.04	3.32	3.61
3.0	1.00	1.20	1.42	1.64	1.88	2.12	2.37	2.63	2.90	3.18	3.46	3.76
3.5		1.30	1.52	1.75	1.99	2.24	2.50	2.76	3.04	3.32	3.61	3.91
4.0			1.62	1.86	2.10	2.36	2.62	2.89	3.17	3.46	3.75	4.05
4.5				1.96	2.21	2.47	2.74	3.02	3.31	3.60	3.90	4.20
5.0					2.33	2.59	2.87	3.15	3.44	3.74	4.04	4.35
5.5						2.71	2.99	3.28	3.71	4.02	4.33	4.65
6.0							2.83	3.11	3.41	3.71	4.02	4.33

For 3 anchors fastening and more

$$X_{ve} = \frac{3 \cdot e + a_1 + a_2 + a_3 + \dots + a_{n-1}}{3 \cdot n \cdot e_m} \cdot \sqrt{e/e_m}$$

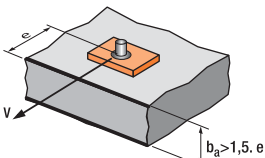

$$X_{ve} = e/e_m \cdot \sqrt{e/e_m}$$

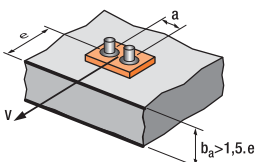

$$X_{ve} = \frac{3 \cdot e + a}{6 \cdot e_m} \cdot \sqrt{e/e_m}$$

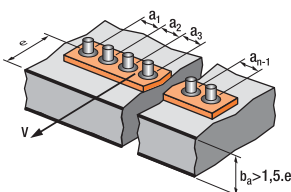

EPCON™ C8 Xtrem™

STRENGTH LIMIT STATE DESIGN

Table 4e Reduced characteristic ultimate concrete pryout capacity, ϕV_{ucp} (kN), $\phi = 1/1.5 = 0.67$, $f'_c = 32$ MPa

Anchor size, d_b	M10	M12	M16	M20	M24	M30
Effective depth, h (mm)	90	110	125	170	210	280
-40 °C to +40 °C	60.3	88.5	125.7	199.4	274.4	457.4
-40 °C to +80 °C	33.9	49.8	71.2	113.9	158.3	246.3

Table 4f - Anchor at a corner effect, concrete edge shear, X_{VS}

Note: For $e_1/e_2 > 1.25$, $X_{VS} = 1.0$

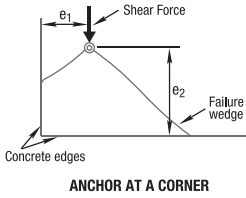

Edge distance, e_2 (mm)	50	60	75	125	200	300	400	600	900
Edge distance, e_1 (mm)									
50	0.86	0.77	0.67	0.52	0.44	0.39	0.37	0.35	0.33
60	0.97	0.86	0.75	0.57	0.47	0.41	0.38	0.36	0.34
75	1.00	1.00	0.86	0.64	0.51	0.44	0.41	0.37	0.35
125	1.00	1.00	1.00	0.86	0.65	0.53	0.48	0.42	0.38
200	1.00	1.00	1.00	1.00	0.86	0.67	0.58	0.49	0.42
300	1.00	1.00	1.00	1.00	1.00	0.86	0.72	0.58	0.49
400	1.00	1.00	1.00	1.00	1.00	1.00	0.86	0.67	0.55
500	1.00	1.00	1.00	1.00	1.00	1.00	1.00	0.77	0.61
600	1.00	1.00	1.00	1.00	1.00	1.00	1.00	0.86	0.67
900	1.00	1.00	1.00	1.00	1.00	1.00	1.00	1.00	0.86

Checkpoint 4a

Design reduced ultimate concrete edge shear capacity, ϕV_{urc}

$$\phi V_{urc} = \phi V_{uc} * X_{vcr} * X_{vc} * X_{vd} * X_{ve} * X_{vs}$$

Checkpoint 4b

Design reduced ultimate concrete pryout capacity, ϕV_{urcp}

$$\phi V_{urcp} = \phi V_{ucp} * X_{ncr} * X_{nc} * X_{ne} * X_{na}$$

STEP 5

Verify concrete shear capacity - per anchor

Table 5a Reduced characteristic ultimate steel shear capacity, ϕV_{usr} (kN) where $\phi_v = 0.67$

Anchor size, d_b	M10	M12	M16	M20	M24	M30
ChemSet™ Anchor Stud Grade 5.8 Carbon Steel	11.8	17.5	33.1	49.9	72.3	-
ChemSet™ Anchor Stud A4/316 Stainless Steel	14.2	21.1	41.4	62.4	90.4	-
ChemSet™ Anchor Stud Grade 8.8 Carbon Steel	17.5	26.0	50.9	76.8	111.3	185.5

Checkpoint 5

Design reduced ultimate shear capacity, ϕV_{ur}

$$\phi V_{ur} = \text{minimum of } \phi V_{urc}, \phi V_{urcp}, \phi V_{usr}$$

Check $V^*/\phi V_{ur} \leq 1$,

if not satisfied return to step 1

EPCON™ C8 Xtrem™

STRENGTH LIMIT STATE DESIGN

STEP 6 Combined Loading

Checkpoint 6

Check
 $N^*/\phi N_{ur} + V^*/\phi V_{ur} \leq 1.2$,
 if not satisfied return to step 1

Specify - Threaded Stud Anchors
 Ramset™ EPCON™ C8 Xtrem™ with (Anchor Size) grade 5.8 ChemSet™ Anchor Stud (Anchor Stud Part Number) Drilled Hole Depth to be (h) mm.

Example
 Ramset™ EPCON™ C8 Xtrem™ with M16 grade 5.8 ChemSet™ Anchor Stud (CS16I90GH). Drilled hole depth to be 125mm. To be installed according to Ramset™ Installation Instructions.

Ramset™ iExpert Anchor Software for optimised calculation or where a greater range of anchor layout detail is needed.

EPCON™ C6 PLUS

CHEMICAL INJECTION - NON-CRACKED & CRACKED CONCRETE

Back to index

AVAILABLE IN NEW ZEALAND ONLY

(Australia refer to ChemSet™ Reo502™ PLUS range)

GENERAL INFORMATION

Performance Related



Material Specification



Installation Related



Product

EPCON™ C6 PLUS is a heavy duty pure Epoxy for anchoring threaded studs and reinforcing bar into cracked and uncracked concrete.



Compliance

European Technical Assessment (option 1) - ETA-18/0675

Design according to:

- EN1992-4 (formerly ETAG001 Annex C, E & TR045)
- Use enclosed data for simplified calculation method

Use Ramset™ iExpert Anchor Software for optimised calculation or where a greater range of anchor layout detail is needed.

Benefits, Advantages and Features

- 100 year working Life

Greater productivity:

- Anchors in dry, damp, wet or flooded holes
- Easy dispensing even in cold weather

Greater security:

- Strong bond
- Rated for sustained loading

Versatile:

- Anchors in carbide drilled and diamond drilled holes*
- Cold and temperate climates

Greater safety:

- Low odour
- VOC Compliant
- Suitable for contact with drinking water



Principal Applications

- Threaded Studs
- Starter Bars
- Threaded Inserts
- Over-head installation
- Steel Columns
- Hand Rails
- Road Stitching

Recommended Installation Temperatures

	Minimum	Maximum
Substrate	5°C	40°C
Adhesive	10°C	40°C

Service Temperature Limits

-40°C to 70°C

Setting Times

Temperature of base material	Cartridge Temperature	Gel Time	Curing time in dry and wet concrete
5°C	Minimum 10°C	300 min	24 h
10°C	10°C	150 min	18 h
15°C	15°C	40 min	12 h
20°C	20°C	25 min	8 h
25°C	25°C	18 min	6 h
30°C	30°C	12 min	4 h
40°C	40°C	6 min	2 h

Note: Cartridge temperature minimum +10°C

Note

*Performance of cored & oversized holes was not included in the ETAG test program and therefore is based on testing conducted at Ramset™ Product Engineering Laboratory.

Installation

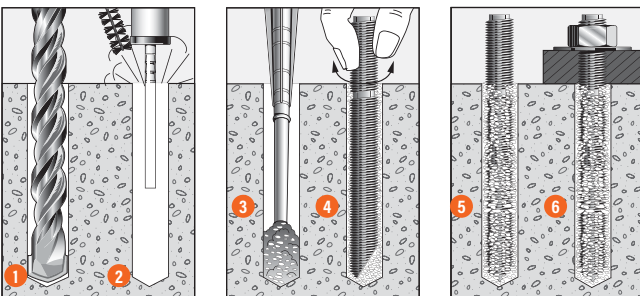

1. Drill recommended diameter and depth hole.
2. **Important:** Use Ramset™ Dustless Drilling System to ensure holes are clean. Alternatively clean dust and debris from hole with stiff wire or nylon brush and blower in the following sequence: blow x 2, brush x 2, blow x 2, brush x 2, blow x 2.
3. Screw mixing nozzle onto cartridge and dispense adhesive to waste until colour is uniform light grey (2-3 trigger pulls). Insert mixing nozzle to bottom of hole. Fill hole to 3/4 the hole depth slowly, ensuring no air pockets form.
4. Insert Ramset™ ChemSet™ Anchor Stud/rebar to bottom of hole while turning.
5. Allow EPCON™ C6 PLUS to cure as per setting times.
6. Attach fixture.

EPCON™ C6 PLUS

CHEMICAL INJECTION - NON-CRACKED & CRACKED CONCRETE

AVAILABLE IN NEW ZEALAND ONLY

Installation and performance details: EPCON™ C6 PLUS and ChemSet™ Anchor Studs

Anchor size, d _b (mm)	Installation Details				Optimum dimensions*		
	Drilled hole diameter, d _h (mm)	Fixture hole diameter, d _f (mm)	Anchor effective depth, h (mm)	Tightening torque, T _r (Nm)	Edge distance, e _c (mm)	Anchor spacing, a _c (mm)	Concrete substrate thickness, b _m (mm)
M10	12	12	90	20	135	270	120
M12	14	14	110	40	165	330	140
M16	18	18	125	80	187.5	375	160
M20	22	22	150	120	225	450	190
			170		255	510	220
M24	26	26	160	160	240	480	200
			210		315	630	270
M30	35	33	280	200	420	840	350

* Note: For shear loads acting towards an edge or where these optimum dimensions are not achievable, please use the simplified strength limit state design process to verify capacity.

Anchor size, d _b (mm)	Reduced Characteristic Capacity#								
	Grade 5.8 Steel Studs		Grade 8.8 Steel Studs		ANSI 316 Stainless Steel Studs		Non-Cracked Concrete		
	Shear, φV _{us} (kN)	Tension, φN _{us} (kN)***	Shear, φV _{us} (kN)	Tension, φN _{us} (kN)***	Shear, φV _{us} (kN)	Tension, φN _{us} (kN)***	Tension, φN _{uc} (kN)**		
							Concrete Compressive Strength, f _c		
							20 MPa	32 MPa	40 MPa
M10	11.8	18.9	17.5	28.2	14.2	19.8	28.0	29.4	30.3
M12	17.5	28.1	26.0	41.9	21.1	29.5	37.8	43.1	44.4
M16	33.1	53.9	50.9	82.1	41.4	57.7	45.8	52.3	53.8
M20	49.9	81.3	76.8	123.9	62.4	87.1	60.2	76.2	80.7
							72.6	88.9	91.4
M24	72.3	117.8	111.3	179.5	90.4	126.2	66.3	84.0	94.0
							99.7	126.2	135.5
M30	-	-	185.5	299.2	-	-	153.5	173.8	178.8

**Note: Reduced characteristic ultimate concrete tensile capacity = φN_{uc} where φ = 0.67 and N_{uc} = Characteristic ultimate concrete tensile capacity.

For conversion to Working Load Limit MULTIPLY φN_{uc} x 0.5

***Note: Reduced characteristic ultimate steel tensile capacity = φN_{us} where φ = 0.67 and N_{us} = Characteristic ultimate steel tensile capacity .

For conversion to Working Load Limit MULTIPLY φN_{us} x 0.67 for Gr 5.8 & Gr 8.8

#Note: Design Tensile Capacity φN_{ur} = minimum of φN_{uc} and φN_{us}

For Cracked Concrete performance, please use the simplified strength limit state design process to verify capacity.

Data is based on a Service temperature limit of -40°C to +70°C

All data relevant for Dry, Wet and Flooded Holes

For optimised performance data, please use Ramset iExpert Anchoring Software.

DESCRIPTION AND PART NUMBERS

Description	Cartridge Size	Part No.
EPCON C6 PLUS	600ml	EC6P600

ENGINEERING PROPERTIES

ChemSet™ Anchor Studs and Threaded Rod

Anchor Size, d _b	Grade 8.8 Threaded Rod				Stainless Steel High Corrosion Resistance HCR Grade 1.4529/1.4565 Threaded Rod				Section modulus Z (mm ³)
	Shank diameter, d _s (mm)	Stressed Area (mm ²)	Yield Strength f _y MPa	UTS f _u MPa	Shank diameter, d _s (mm)	Stressed Area (mm ²)	Yield Strength f _y MPa	UTS f _u MPa	
M10	8.6	58	640	800	8.2	52.8	450	650	62.3
M12	10.4	84.3	640	800	10	78.5	450	650	109.2
M16	14.1	157	640	800	14	153.9	450	650	277.5
M20	17.7	245	640	800	17.2	232.4	450	650	540.9
M24	21.2	353	640	800	20.7	336.5	450	650	935.5
M30	26.7	561	640	800	-	-	-	-	-

Refer to "Engineering Properties" for ChemSet™ Anchor Studs Grade 5.8 and AISI 316 Stainless Steel in the SARB ANZ on page 141.

EPCON™ C6 PLUS

STRENGTH LIMIT STATE DESIGN

AVAILABLE IN NEW ZEALAND ONLY

STEP 1 Select anchor to be evaluated

Table 1a Indicative combined loading - interaction diagram

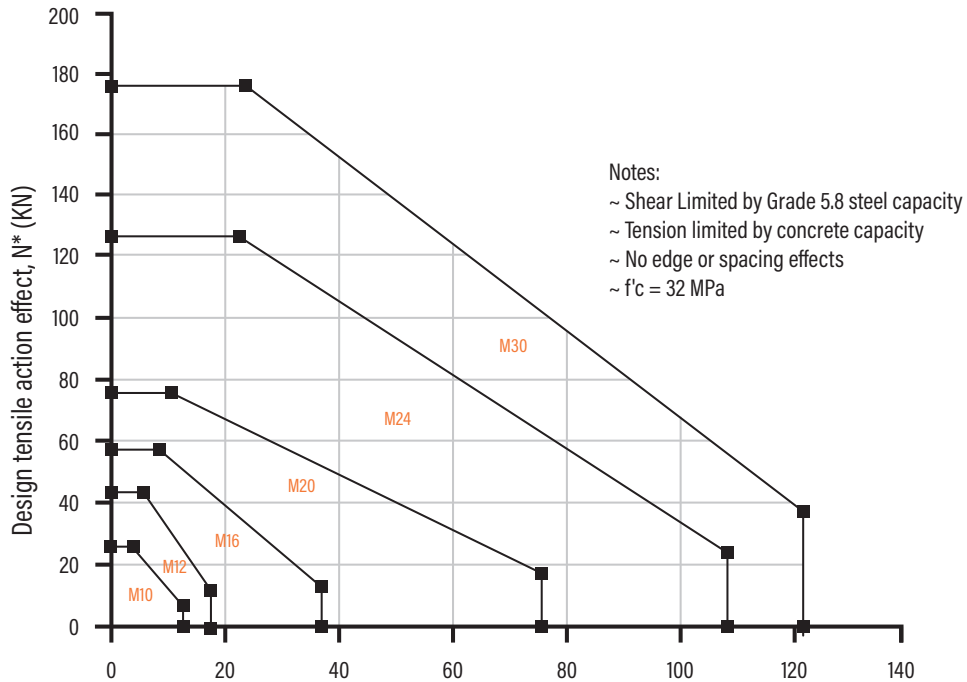

Table 1b Absolute minimum edge distance and anchor spacing values, e_m and a_m (mm)

Anchor size, d_s M10	M10	M12	M16	M20	M24	M30
Min. Anchor Spacing - a_m	40	40	40	50	50	60
Min. Edge Distance - e_m	40	40	40	50	50	60

Step 1c Calculate anchor effective depth, h (mm)

Refer to "Description and Part Numbers" table for ChemSet Anchor Studs page in the SARB ANZ on page 141.

Effective depth, h (mm)
 Preferred $h = h_n$ otherwise,
 $h = L_e - t$
 t = total thickness of material(s) being fastened.

Substrate thickness b_m (mm)		
Anchor Stud Size (mm)		
M10	M12	M16 to M30
$h + 30\text{mm} \geq 100\text{mm}$		$h + (2 \times d_s)$

Checkpoint 1 Anchor size determined, absolute minima compliance achieved, effective depth (h) calculated.

EPCON™ C6 PLUS

STRENGTH LIMIT STATE DESIGN

AVAILABLE IN NEW ZEALAND ONLY

STEP 2 Verify concrete tensile capacity - per anchor

Table 2a Reduced characteristic ultimate concrete tensile capacity, ϕN_{uc} (kN), $\phi_c = 1/1.5 = 0.67$, $f'_c = 32$ MPa

Anchor Size, d_b	Combined pull-out and concrete cone resistance - ϕN_{ucp}						Concrete Cone Resistance - ϕN_{ucc}
	M10	M12	M16	M20	M24	M30	
Drilled Hole Dia, d_h (mm)	12	14	18	22	26	35	
Effective Depth, h (mm)							
70	22.9						24.3
80	26.1						29.7
90	29.4	35.3					35.4
100	32.7	39.2					41.5
110	35.9	43.1	46.0				47.9
120	39.2	47.0	50.2				54.5
125	40.8	49.0	52.3				58.0
140	45.7	54.9	58.5				68.7
150	49.0	58.8	62.7	78.4			76.2
160	52.3	62.7	66.9	83.6	100.4		84.0
170	55.5	66.7	71.1	88.9	106.6		91.9
180	58.8	70.6	75.3	94.1	112.9		100.2
190	62.1	74.5	79.5	99.3	119.2		108.6
200	65.3	78.4	83.6	104.6	125.5		117.3
210		82.3	87.8	109.8	131.7	130.4	126.2
240		94.1	100.4	125.5	150.6	149.0	154.2
280			117.1	146.4	175.6	173.8	194.4
320			133.8	167.3	200.7	198.6	237.5
350				183.0	219.6	217.3	271.6
400				209.1	250.9	248.3	331.9
450					282.3	279.4	396.0
480					301.1	298.0	436.3
550						341.4	535.1
600						372.5	609.7

For optimised performance data, please use Ramset iExpert Anchoring Software.

Table 2a-2 Cracked Concrete effect, tension, X_{ncr}

Anchor Size, d_b	Cracked Concrete Effect - X_{ncr}						X_{ncr}
	where $\phi N_{uc} = \phi N_{ucp}$ (from Table 2a)						
f'_c (MPa)	M10	M12	M16	M20	M24	M30	where $\phi N_{uc} = \phi N_{ucc}$ (from Table 2a)
20 to 50	0.67	0.67	0.79	0.75	0.75	0.63	0.70

Bold values are at Chemset Anchor Stud nominal Depths

For Sustained Loads MULTIPLY ϕN_{uc} x 0.6 (100 years) or ϕN_{uc} x 0.72 (50 years)

All data relevant for Dry, Wet and Flooded Holes.

For Non-cracked concrete $X_{ncr} = 1$.

Calculate ϕN_{urc} for both ϕN_{ucp} and ϕN_{ucc} then choose the minimum - Refer to Checkpoint 2

Table 2b-1 Concrete service temperature limits effect, tension, X_{ns}

Anchor Size, d_b	Service temperature limits effect, tension, X_{ns}						X_{ns}
	M10	M12	M16	M20	M24	M30	
Service temperature (°C)							where $\phi N_{uc} = \phi N_{ucc}$ (from Table 2a)
-40°C to +70°C	1.00						1.00

Table 2b-2 Concrete compressive strength effect, tension, X_{nc}

Anchor Size, d_b	Cracked & Non-Cracked Concrete - X_{nc}						X_{nc}
	where $\phi N_{uc} = \phi N_{ucp}$ (from Table 2a)						
f'_c (MPa)	M10	M12	M16	M20	M24	M30	where $\phi N_{uc} = \phi N_{ucc}$ (from Table 2a)
20	0.96	0.96	0.96	0.96	0.96	0.96	0.79
25	0.98	0.98	0.98	0.98	0.98	0.98	0.88
32	1.00	1.00	1.00	1.00	1.00	1.00	1.00
40	1.03	1.03	1.03	1.03	1.03	1.03	1.12
50	1.05	1.05	1.05	1.05	1.05	1.05	1.25

Chemical Anchoring - Anchor Studs

EPCON™ C6 PLUS

STRENGTH LIMIT STATE DESIGN

AVAILABLE IN NEW ZEALAND ONLY

Chemical Anchoring - Anchor Studs

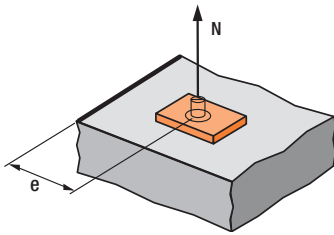

$$X_{ne} = 0.25 + 0.5*(e/h)$$

Where $e_m \leq e \leq e_c$

$$e_c = 1.5*h$$

Note: Tabled values are based on the nominal effective depth, h shown in the installation details. For other values of X_{ne} , please use equation shown above.

Table 2c - Concrete Edge distance effect, tension, X_{ne}

Anchor size, d_b	M10	M12	M16	M20	M24	M30
Edge distance, e (mm)						
40	0.47	0.43	0.41			
45	0.50	0.45	0.43			
50	0.53	0.48	0.45	0.40	0.36	
55	0.56	0.50	0.47	0.41	0.38	
65	0.61	0.55	0.51	0.44	0.40	0.37
70	0.64	0.57	0.53	0.46	0.42	0.38
80	0.69	0.61	0.57	0.49	0.44	0.39
100	0.81	0.70	0.65	0.54	0.49	0.43
115	0.89	0.77	0.71	0.59	0.52	0.46
135	1	0.86	0.79	0.65	0.57	0.49
165		1	0.91	0.74	0.64	0.54
187			1	0.80	0.70	0.58
255				1	0.86	0.71
315					1	0.81
420						1

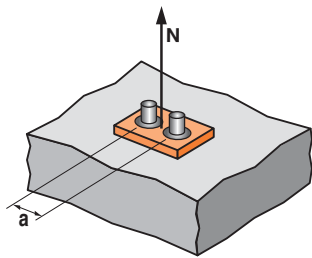

$$X_{na} = 0.5 + a/(6*h)$$

Where $a_m \leq a \leq a_c$

$$a_c = 3*h$$

Note: Tabled values are based on the nominal effective depth, h shown in the installation details. For other values X_{na} , please use equation shown above.

Table 2d - Concrete anchor spacing effect, tension, X_{na}

Anchor size, d_b	M10	M12	M16	M20	M24	M30
Anchor spacing, a (mm)						
40	0.57	0.56	0.55			
45	0.58	0.57	0.56			
50	0.59	0.58	0.57	0.55	0.53	
55	0.60	0.58	0.57	0.55	0.54	
65	0.62	0.60	0.59	0.56	0.55	0.54
85	0.66	0.63	0.61	0.58	0.57	0.55
100	0.69	0.65	0.63	0.60	0.58	0.56
125	0.73	0.69	0.67	0.62	0.60	0.57
150	0.78	0.73	0.70	0.65	0.62	0.59
200	0.87	0.80	0.77	0.70	0.66	0.62
270	1	0.91	0.86	0.76	0.71	0.66
330		1	0.94	0.82	0.76	0.70
375			1	0.87	0.80	0.72
510				1	0.90	0.80
630					1	0.88
840						1

Checkpoint 2

Design reduced ultimate concrete tensile capacity, ϕN_{urc}

$$\phi N_{urc} = \text{minimum of } \phi N_{ucp} * X_{ncr} * X_{ns} * X_{nc} * X_{ne} * X_{na} \text{ and } \phi N_{ucc} * X_{ncr} * X_{ns} * X_{nc} * X_{ne} * X_{na}$$

STEP 3

Verify anchor tensile capacity - per anchor

Table 3a Reduced characteristic ultimate steel tensile capacity, ϕN_{us} (kN) where $\phi_n = 0.67$ for Gr 5.8 & Gr 8.8

Anchor size, d_b	M10	M12	M16	M20	M24	M30
ChemSet™ Anchor Stud Grade 5.8 Carbon Steel	18.9	28.1	53.9	81.3	117.8	-
ChemSet™ Anchor Stud A4/316 Stainless Steel	19.8	29.5	57.7	87.1	126.2	-
ChemSet™ Anchor Stud Grade 8.8 Carbon Steel	28.2	41.9	82.1	123.9	179.5	299.2

Note $\phi_n = 0.58$ for ChemSet™ Anchor Stud A4/316 Stainless Steel

Checkpoint 3

Design reduced ultimate tensile capacity, ϕN_{ur}

$$\phi N_{ur} = \text{minimum of } \phi N_{urc} \text{ and } \phi N_{us}$$

Check $N^*/\phi N_{ur} \leq 1.0$,

if not satisfied return to step 1

EPCON™ C6 PLUS

STRENGTH LIMIT STATE DESIGN

AVAILABLE IN NEW ZEALAND ONLY

STEP 4

Step 4 - Verify concrete shear capacity - per anchor

Table 4a Reduced characteristic ultimate concrete edge shear capacity, ϕV_{uc} (kN), $\phi = 1/1.5 = 0.67$, $f'_c = 32$ MPa

Anchor size, d_b	M10	M12	M16	M20	M24	M30
Effective depth, h (mm)	70 - 200	90 - 240	110 - 320	150 - 400	160 - 480	210 - 600
Edge distance, e_m						
40	4.3	4.7	5.4			
50				8.2	8.8	
60						12.7

For optimised performance data, please use Ramset iExpert Anchoring Software.

Table 4a-2 Cracked Concrete effect, shear, X_{vcr}

Anchor size, d_b	M10	M12	M16	M20	M24	M30
X_{vcr}	0.70					

For Non-cracked concrete $X_{vcr} = 1.0$

Table 4b - Concrete compressive strength effect, shear, X_{vc}

f'_c (MPa)	20	25	32	40	50
X_{vc}	0.79	0.86	1	1.11	1.22

Table 4c - Concrete load direction effect, concrete edge shear, X_{vd}

Angle, α°	0-55	60	70	80	90-180
X_{vd}	1	1.1	1.2	1.5	2

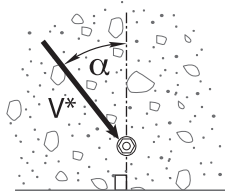

Load direction effect, conc. edge shear, X_{vd}

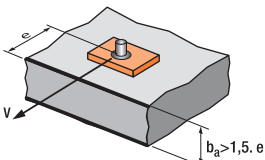

$$X_{ve} = e/e_m * \sqrt{e/e_m}$$

Table 4d - Concrete anchor spacing and edge distance effect, concrete edge shear, X_{ve}

For single anchor fastening X_{ve}

e/e_m	1.0	1.2	1.4	1.6	1.8	2.0	2.2	2.4	2.6	2.8	3.0	3.2
X_{ve}	1.00	1.31	1.66	2.02	2.41	2.83	3.26	3.72	4.19	4.69	5.20	5.72

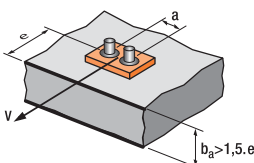

$$X_{ve} = \frac{3*e+a}{6*e_m} * \sqrt{e/e_m}$$

For 2 anchors fastening X_{ve}

e/e_m	1.0	1.2	1.4	1.6	1.8	2.0	2.2	2.4	2.6	2.8	3.0	3.2
a/e_m												
1.0	0.67	0.84	1.03	1.22	1.43	1.65	1.88	2.12	2.36	2.62	2.89	3.16
1.5	0.75	0.93	1.12	1.33	1.54	1.77	2.00	2.25	2.50	2.76	3.03	3.31
2.0	0.83	1.02	1.22	1.43	1.65	1.89	2.12	2.38	2.63	2.90	3.18	3.46
2.5	0.92	1.11	1.32	1.54	1.77	2.00	2.25	2.50	2.77	3.04	3.32	3.61
3.0	1.00	1.20	1.42	1.64	1.88	2.12	2.37	2.63	2.90	3.18	3.46	3.76
3.5		1.30	1.52	1.75	1.99	2.24	2.50	2.76	3.04	3.32	3.61	3.91
4.0			1.62	1.86	2.10	2.36	2.62	2.89	3.17	3.46	3.75	4.05
4.5				1.96	2.21	2.47	2.74	3.02	3.31	3.60	3.90	4.20
5.0					2.33	2.59	2.87	3.15	3.44	3.74	4.04	4.35
5.5						2.71	2.99	3.28	3.71	4.02	4.33	4.65
6.0							2.83	3.11	3.41	3.71	4.02	4.33

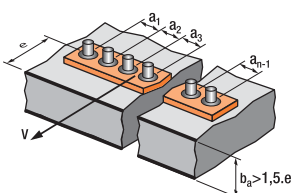

For 3 anchors fastening and more

$$X_{ve} = \frac{3*e + a_1 + a_2 + a_3 + \dots + a_{n-1}}{3*n*e_m} * \sqrt{e/e_m}$$

EPCON™ C6 PLUS

STRENGTH LIMIT STATE DESIGN

AVAILABLE IN NEW ZEALAND ONLY

Table 4e Reduced characteristic ultimate concrete pryout capacity, ϕV_{ucp} (kN), $\phi = 1/1.5 = 0.67$, $f'_c = 32$ MPa

Anchor size, d_b	M10	M12	M16	M20	M24	M30
Effective depth, h (mm)	90	110	125	170	210	280
-40 °C to +70 °C	58.8	86.3	104.6	177.7	263.5	335.2

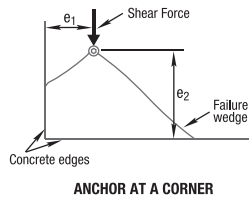

Table 4f Anchor at a corner effect, concrete edge shear, X_{vs}

Note: For $e_1/e_2 > 1.25$, $X_{vs} = 1.0$

Edge distance, e_2 (mm)	25	30	35	50	60	75	125	200	300	400	600	900
Edge distance, e_1 (mm)												
25	0.86	0.77	0.70	0.58	0.53	0.49	0.41	0.37	0.35	0.34	0.32	0.32
30	0.97	0.86	0.78	0.64	0.58	0.52	0.43	0.38	0.36	0.34	0.33	0.32
35	1.00	0.95	0.86	0.69	0.63	0.56	0.46	0.40	0.37	0.35	0.33	0.32
50	1.00	1.00	1.00	0.86	0.77	0.67	0.52	0.44	0.39	0.37	0.35	0.33
60	1.00	1.00	1.00	0.97	0.86	0.75	0.57	0.47	0.41	0.38	0.36	0.34
75	1.00	1.00	1.00	1.00	1.00	0.86	0.64	0.51	0.44	0.41	0.37	0.35
125	1.00	1.00	1.00	1.00	1.00	1.00	0.86	0.65	0.53	0.48	0.42	0.38
200	1.00	1.00	1.00	1.00	1.00	1.00	1.00	0.86	0.67	0.58	0.49	0.42
300	1.00	1.00	1.00	1.00	1.00	1.00	1.00	1.00	0.86	0.72	0.58	0.49
400	1.00	1.00	1.00	1.00	1.00	1.00	1.00	1.00	1.00	0.86	0.67	0.55
500	1.00	1.00	1.00	1.00	1.00	1.00	1.00	1.00	1.00	1.00	0.77	0.61
600	1.00	1.00	1.00	1.00	1.00	1.00	1.00	1.00	1.00	1.00	0.86	0.67
900	1.00	1.00	1.00	1.00	1.00	1.00	1.00	1.00	1.00	1.00	1.00	0.86

Checkpoint **4a**

Design reduced ultimate concrete edge shear capacity, ϕV_{urc}

$$\phi V_{urc} = \phi V_{uc} * X_{vcr} * X_{vc} * X_{vd} * X_{ve} * X_{vs}$$

Checkpoint **4b**

Design reduced ultimate concrete pryout capacity, ϕV_{urcp}

$$\phi V_{urcp} = \phi V_{ucp} * X_{ncr} * X_{nc} * X_{ne} * X_{na}$$

STEP **5**

Verify anchor shear capacity - per anchor

Table 5a Reduced characteristic ultimate steel shear capacity, ϕV_{usr} (kN) where $\phi_v = 0.67$

Anchor size, d_b	M10	M12	M16	M20	M24	M30
ChemSet™ Anchor Stud Grade 5.8 Carbon Steel	11.8	17.5	33.1	49.9	72.3	-
ChemSet™ Anchor Stud A4/316 Stainless Steel	14.2	21.1	41.4	62.4	90.4	-
ChemSet™ Anchor Stud Grade 8.8 Carbon Steel	17.5	26.0	50.9	76.8	111.3	185.5

Checkpoint **5**

Design reduced ultimate shear capacity, ϕV_{ur}

$$\phi V_{ur} = \text{minimum of } \phi V_{urc} \phi V_{urcp} \phi V_{usr}$$

Check $V^*/\phi V_{ur} \leq 1.0$,

if not satisfied return to step 1

EPCON™ C6 PLUS

STRENGTH LIMIT STATE DESIGN

AVAILABLE IN NEW ZEALAND ONLY

STEP 6 Combined Loading

Checkpoint 6

Check

$N^*/\phi N_{ur} + V^*/\phi V_{ur} \leq 1.2$,
if not satisfied return to step 1

Specify - Threaded Stud Anchors
Ramset™ EPCON™ C6 PLUS with (Anchor Size)
grade 5.8 Chemset™ Anchor Stud (Anchor
Stud Part Number) Drilled Hole Depth to be
(h) mm.

Example
Ramset™ EPCON™ C6 PLUS Injection with
M16 grade 5.8 Chemset™ Anchor Stud
(CS16190GH). Drilled hole depth to be
125mm. To be installed according to
Ramset™ Installation Instructions.

Ramset™ iExpert Anchor Software for optimised calculation or where a greater range of anchor layout detail is needed.

ChemSet™ 801 Xtrem™ XC²

CHEMICAL INJECTION - NON-CRACKED & CRACKED CONCRETE

[Back to index](#)

GENERAL INFORMATION

Performance Related	Material Specification	Installation Related

Product

Chemset™ 801 Xtrem™ XC² is a heavy duty Vinylester for anchoring threaded studs and reinforcing bar into cracked and uncracked concrete.



Compliance

European Technical Assessment (option 1) - ETA-18/0045

Design according to:

- AS5216 (formerly TS101)
- EN1992-4 (formerly ETAG001 Annex C, E & TR045)
- Use enclosed data for simplified calculation method

Use Ramset™ iExpert Anchor Software for optimised calculation or where a greater range of anchor layout detail is needed.

Benefits, Advantages and Features

- 50 year working Life
- Flooded Holes
- Fire rated

Greater productivity:

- Easy dispensing even in cold weather
- Apply torque in 2 hours @ 20°C

Greater security:

- Strong bond
- Rated for sustained loading

Versatile:

- Earthquake, Fire & Flooded Conditions
- Cold and temperate climates

Greater safety:

- Low odour
- VOC Compliant
- Suitable for contact with drinking water

Made in Australia



Principal Applications

- Threaded Studs
- Starter Bars
- Threaded Inserts
- Over-head installation
- Steel Columns
- Hand Rails
- Road Stitching

Recommended Installation Temperatures

	Minimum	Maximum
Substrate	5°C	40°C
Adhesive	5°C	40°C

Service Temperature Limits

-40°C to 80°C

Setting Times

Temperature of base material	Gel Time	Curing time in dry concrete	Curing time in wet concrete
+5°C	60 min	240 min	480 min
6°C - 10°C	40 min	180 min	360 min
11°C - 20°C	15 min	120 min	240 min
21°C - 30°C	8 min	90 min	180 min
31°C - 40°C	4 min	60 min	120 min

Note: Cartridge temperature minimum +5°C

Installation

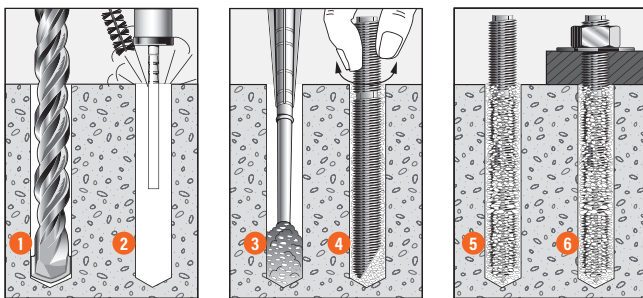

- Drill recommended diameter and depth hole.
- Important:** Use Ramset™ Dustless Drilling System to ensure holes are clean. Alternatively clean dust and debris from hole with stiff wire or nylon brush and blower in the following sequence: blow x 2, brush x 2, blow x 2.
- Dispense adhesive to waste until colour is uniform light grey (2-3 trigger pulls). Insert mixing nozzle to bottom of hole. Fill hole to 3/4 the hole depth slowly, ensuring no air pockets form.
- Insert Ramset™ ChemSet™ Anchor Stud/rebar to bottom of hole while turning.
- Allow Chemset™ 801 Xtrem™ XC² to cure as per setting times.
- Attach fixture.

ChemSet™ 801 Xtrem™ XC²

CHEMICAL INJECTION - NON-CRACKED & CRACKED CONCRETE

Installation and performance details: ChemSet™ 801 Xtrem™ XC² and ChemSet™ Anchor Studs

Anchor size, d _b (mm)	Installation Details				Optimum dimensions*		
	Drilled hole diameter, d _h (mm)	Fixture hole diameter, d _f (mm)	Anchor effective depth, h (mm)	Tightening torque, T _r (Nm)	Edge distance, e _c (mm)	Anchor spacing, a _c (mm)	Concrete substrate thickness, b _m (mm)
M10	12	12	90	20	135	270	120
M12	14	14	110	30	165	330	140
M16	18	18	125	60	187	375	160
M20	25	22	150	120	225	450	190
			170		255	510	220
M24	28	26	160	200	240	480	200
			210		315	630	270
M30	35	33	280	400	420	840	350

* Note: For shear loads acting towards an edge or where these optimum dimensions are not achievable, please use the simplified strength limit state design process to verify capacity.

Anchor size, d _b (mm)	Reduced Characteristic Capacity#								
	Grade 5.8 Steel Studs		Grade 8.8 Steel Studs		ANSI 316 Stainless Steel Studs		Non-Cracked Concrete		
	Shear, φV _{us} (kN)	Tension, φN _{us} (kN)***	Shear, φV _{us} (kN)	Tension, φN _{us} (kN)***	Shear, φV _{us} (kN)	Tension, φN _{us} (kN)***	Tension, φN _{uc} (kN)**		
							Concrete Compressive Strength, f' _c		
20 MPa			32 MPa			40 MPa			
M10	11.8	18.9	17.5	28.2	14.2	19.8	28.0	29.4	30.3
M12	17.5	28.1	26.0	41.9	21.1	29.5	37.8	43.1	44.4
M16	33.1	53.9	50.9	82.1	41.4	57.7	45.8	56.6	58.3
M20	49.9	81.3	76.8	123.9	62.4	87.1	60.2	76.2	85.0
							72.6	87.7	96.3
M24	72.3	117.8	111.3	179.5	90.4	126.2	66.3	84.0	94.0
							93.4	118.2	129.8
M30	-	-	185.5	299.2	-	-	149.5	175.0	197.4

**Note: Reduced characteristic ultimate concrete tensile capacity = φN_{uc} where φ = 0.67 and N_{uc} = Characteristic ultimate concrete tensile capacity.

For conversion to Working Load Limit MULTIPLY φN_{uc} x 0.5

***Note: Reduced characteristic ultimate steel tensile capacity = φN_{us} where φ = 0.67 and N_{us} = Characteristic ultimate steel tensile capacity.

For conversion to Working Load Limit MULTIPLY φN_{us} x 0.67 for Gr 5.8 & Gr 8.8

#Note: Design Tensile Capacity φN_{ur} = minimum of φN_{uc} and φN_{us}

For Cracked Concrete performance, please use the simplified strength limit state design process to verify capacity.

Data is based on a Service temperature limit of -40°C to +70°C

Flooded Holes: Multiply φN_{uc} x 0.75, Max Embedment is limited to 12d for flooded holes.

For optimised performance data, please use Ramset iExpert Anchoring Software.

DESCRIPTION AND PART NUMBERS

Description	Cartridge Size	Part No.
ChemSet™ 801 Xtrem™ XC ²	750ml	C801X750 (AU & NZ)
ChemSet™ 801 Xtrem™ XC ²	380ml	C801X380 (AU Only)

ENGINEERING PROPERTIES

ChemSet™ Anchor Studs and Threaded Rod

Anchor Size, d _b	Grade 8.8 Threaded Rod				Stainless Steel High Corrosion Resistance HCR Grade 1.4529/1.4565 Threaded Rod				Section modulus Z (mm ³)
	Shank diameter, d _s (mm)	Stressed Area (mm ²)	Yield Strength f _y MPa	UTS f _u MPa	Shank diameter, d _s (mm)	Stressed Area (mm ²)	Yield Strength f _y MPa	UTS f _u MPa	
M10	8.6	58	640	800	8.2	52.8	450	650	62.3
M12	10.4	84.3	640	800	10	78.5	450	650	109.2
M16	14.1	157	640	800	14	153.9	450	650	277.5
M20	17.7	245	640	800	17.2	232.4	450	650	540.9
M24	21.2	353	640	800	20.7	336.5	450	650	935.5
M30	26.7	561	640	800	-	-	-	-	-

Refer to "Engineering Properties" for ChemSet™ Anchor Studs Grade 5.8 and AISI 316 Stainless Steel in the SARB ANZ on page 143

ChemSet™ 801 Xtrem™ XC²

STRENGTH LIMIT STATE DESIGN

STEP 1 Select anchor to be evaluated

Table 1a Indicative combined loading - interaction diagram

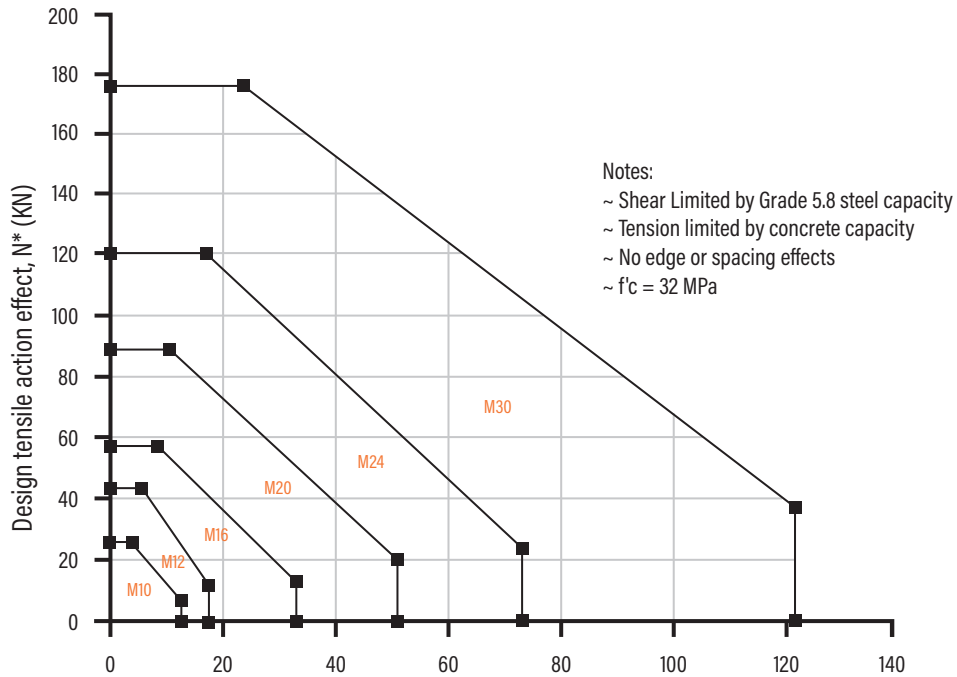

Table 1b Absolute minimum edge distance and anchor spacing values, e_m and a_m (mm)

Anchor size, d_s	M10	M12	M16	M20	M24	M30
Min. Anchor Spacing - a_m	50	60	75	90	115	140
Min. Edge Distance - e_m	45	45	50	55	60	80

Step 1c Calculate anchor effective depth, h (mm)

Refer to "Description and Part Numbers" table for ChemSet Anchor Studs page in the SARB ANZ on page 141.

Effective depth, h (mm)

Preferred $h = h_n$ otherwise,

$h = L_e - t$

t = total thickness of material(s) being fastened.

Substrate thickness b_m (mm)					
Anchor Stud Size (mm)					
M10	M12	M16	M20	M24	M30
$h + 30\text{mm} \geq 100\text{mm}$			$h + (2 \times d_s)$		

Checkpoint 1 Anchor size determined, absolute minima compliance achieved, effective depth (h) calculated.

ChemSet™ 801 Xtrem™ XC²

STRENGTH LIMIT STATE DESIGN

STEP

2

Verify concrete tensile capacity - per anchor

Table 2a Reduced characteristic ultimate concrete tensile capacity, ϕN_{uc} (kN), $\phi_c = 1/1.5 = 0.67$, $f'_c = 32$ MPa

Anchor Size, d_b	Combined pull-out and concrete cone resistance - ϕN_{ucp}						Concrete Cone Resistance - ϕN_{uc}
	M10	M12	M16	M20	M24	M30	
Drilled Hole Dia, d_h (mm)	12	14	18	25	28	35	
Effective Depth, h (mm)							
70	22.9						24.3
80	26.1						29.7
90	29.4	35.3					35.4
100	32.7	39.2					41.5
110	35.9	43.1	49.8				47.9
120	39.2	47.0	54.4				54.5
125	40.8	49.0	56.6				58.0
140	45.7	54.9	63.4				68.7
150	49.0	58.8	68.0	77.4			76.2
160	52.3	62.7	72.5	82.6			84.0
170	55.5	66.7	77.0	87.7	95.7		91.9
180	58.8	70.6	81.6	92.9	101.3		100.2
190	62.1	74.5	86.1	98.1	107.0		108.6
200	65.3	78.4	90.6	103.2	112.6		117.3
210		82.3	95.1	108.4	118.2	131.2	126.2
240		94.1	108.7	123.9	135.1	150.0	154.2
280			126.9	144.5	157.6	175.0	194.4
320			145.0	165.1	180.2	200.0	237.5
350				180.6	197.0	218.7	271.6
400				206.4	225.2	249.9	331.9
450					253.3	281.2	396.0
480					270.2	299.9	436.3
550						343.7	535.1
600						374.9	609.7

For optimised performance data, please use Ramset iExpert Anchoring Software.

Table 2a-2 Cracked Concrete effect, tension, X_{ncr}

Anchor Size, d_b	Cracked Concrete Effect - X_{ncr}						X_{ncr}
	M10	M12	M16	M20	M24	M30	
f'_c (MPa)							where $\phi N_{uc} = \phi N_{ucp}$ (from Table 2a)
20 to 50	0.43	0.43	0.50	0.59	0.65	0.68	0.70

Bold values are at Chemset Anchor Stud nominal Depths

For Sustained Loads MULTIPLY $\phi N_{uc} \times 0.6$

Flooded Holes: Multiply $\phi N_{uc} \times 0.75$

For Non-cracked concrete $X_{ncr} = 1$.

Note: The maximum embedment depth shall be reduced to $12d_b$ for installation in flooded holes

If Service temperature limit is -40°C to +40°C then Refer to Checkpoint 2	If Service temperature limit is -40°C to +80°C then $\phi N_{uc} = \phi N_{ucp}$
---	--

Table 2b-1 Concrete service temperature limits effect, tension, X_{ns}

Anchor Size, d_b	Service temperature limits effect, tension, X_{ns}						X_{ns}
	M10	M12	M16	M20	M24	M30	
Service temperature (°C)							where $\phi N_{uc} = \phi N_{ucp}$ (from Table 2a)
-40 °C to +40 °C				1.00			1.00
-40 °C to +80 °C				0.90			1.00

Table 2b-2 Concrete compressive strength effect, tension, X_{nc}

NON- CRACKED	Non-Cracked Concrete - X_{nc}						X_{nc}
	M10	M12	M16	M20	M24	M30	
Anchor Size, d_b							where $\phi N_{uc} = \phi N_{ucp}$ (from Table 2a)
f'_c (MPa)							
20	0.96	0.96	0.96	0.89	0.89	0.85	0.79
25	0.96	0.96	0.96	0.89	0.89	0.85	0.88
32	1.00	1.00	1.00	1.00	1.00	1.00	1.00
40	1.03	1.03	1.03	1.10	1.10	1.13	1.12
50	1.05	1.05	1.05	1.16	1.16	1.21	1.25

CRACKED	Cracked Concrete - X_{nc}						X_{nc}
	M10	M12	M16	M20	M24	M30	
Anchor Size, d_b							where $\phi N_{uc} = \phi N_{ucp}$ (from Table 2a)
f'_c (MPa)							
20							0.79
25							0.88
32	0.96	0.96	0.96	0.89	0.89	0.85	1.00
40							1.12
50							1.25

ChemSet™ 801 Xtrem™ XC²

STRENGTH LIMIT STATE DESIGN

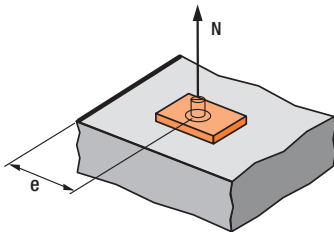

$$X_{ne} = 0.25 + 0.5 \cdot (e/h)$$

Where $e_m \leq e \leq e_c$

$$e_c = 1.5 \cdot h$$

Note: Tabled values are based on the nominal effective depth, h shown in the installation details. For other values of X_{ne} , please use equation shown above.

Table 2c - Concrete Edge distance effect, tension, X_{ne}

Anchor size, d_b	M10	M12	M16	M20	M24	M30
Edge distance, e (mm)						
45	0.50	0.45				
50	0.53	0.48	0.45			
55	0.56	0.50	0.47	0.41		
60	0.58	0.52	0.49	0.43	0.39	
80	0.69	0.61	0.57	0.49	0.44	0.39
90	0.75	0.66	0.61	0.51	0.46	0.41
100	0.81	0.70	0.65	0.54	0.49	0.43
120	0.92	0.80	0.73	0.60	0.54	0.46
135	1	0.86	0.79	0.65	0.57	0.49
165		1	0.91	0.74	0.64	0.54
187			1	0.80	0.70	0.58
255				1	0.86	0.71
315					1	0.81
420						1

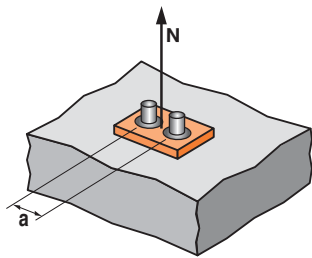

$$X_{na} = 0.5 + a/(6 \cdot h)$$

Where $a_m \leq a \leq a_c$

$$a_c = 3 \cdot h$$

Note: Tabled values are based on the nominal effective depth, h shown in the installation details. For other values X_{na} , please use equation shown above.

Table 2d - Concrete anchor spacing effect, tension, X_{na}

Anchor size, d_b	M10	M12	M16	M20	M24	M30
Anchor spacing, a (mm)						
50	0.59					
60	0.61	0.59				
75	0.64	0.61	0.60			
90	0.67	0.64	0.62	0.59		
115	0.71	0.67	0.65	0.61	0.59	
130	0.74	0.70	0.67	0.63	0.60	
140	0.76	0.71	0.69	0.64	0.61	0.58
150	0.78	0.73	0.70	0.65	0.62	0.59
200	0.87	0.80	0.77	0.70	0.66	0.62
270	1	0.91	0.86	0.76	0.71	0.66
330		1	0.94	0.82	0.76	0.70
375			1	0.87	0.80	0.72
510				1	0.90	0.80
630					1	0.88
840						1

Checkpoint 2

Design reduced ultimate concrete tensile capacity, ϕN_{urc}

$$\phi N_{urc} = \phi N_{uc} \cdot X_{ncr} \cdot X_{ns} \cdot X_{nc} \cdot X_{ne} \cdot X_{na}$$

If Service temperature limit is -40°C to +40°C then

$$\phi N_{urc} = \text{minimum of } \phi N_{ucp} \cdot X_{ncr} \cdot X_{ns} \cdot X_{nc} \cdot X_{ne} \cdot X_{na} \text{ and } \phi N_{ucc} \cdot X_{ncr} \cdot X_{ns} \cdot X_{nc} \cdot X_{ne} \cdot X_{na}$$

STEP 3

Verify anchor tensile capacity - per anchor

Table 3a Reduced characteristic ultimate steel tensile capacity, ϕN_{us} (kN) where $\phi_n = 0.67$ for Gr 5.8 & Gr 8.8

Anchor size, d_b	M10	M12	M16	M20	M24	M30
ChemSet™ Anchor Stud Grade 5.8 Carbon Steel	18.9	28.1	53.9	81.3	117.8	-
ChemSet™ Anchor Stud A4/316 Stainless Steel	19.8	29.5	57.7	87.1	126.2	-
ChemSet™ Anchor Stud Grade 8.8 Carbon Steel	28.2	41.9	82.1	123.9	179.5	299.2

Note: $\phi_n = 0.58$ for ChemSet™ Anchor Stud A4/316 Stainless Steel

Checkpoint 3

Design reduced ultimate tensile capacity, ϕN_{ur}

$$\phi N_{ur} = \text{minimum of } \phi N_{urc}, \phi N_{us}$$

Check $N^*/\phi N_{ur} \leq 1$,

if not satisfied return to step 1

ChemSet™ 801 Xtrem™ XC²

STRENGTH LIMIT STATE DESIGN

STEP 4

Step 4 - Verify Concrete Shear Capacity - per anchor

Table 4a-1 Reduced characteristic ultimate concrete edge shear capacity, ϕV_{uc} (kN), $\phi = 1/1.5 = 0.67$, $f'_c = 32$ MPa

Anchor size, d_b	M10	M12	M16	M20	M24	M30
Effective depth, h (mm)	70 - 200	90 - 240	110 - 320	150 - 400	170 - 480	210 - 600
Edge distance, e_m						
45	5.0	5.5				
50			7.0			
55				9.1		
60					11.0	
80						17.4

For optimised performance data, please use Ramset iExpert Anchoring Software.

Table 4a-2 Cracked Concrete effect, shear, X_{vcr}

Anchor size, d_b	M10	M12	M16	M20	M24	M30
X_{vcr}	0.70					

For Non-cracked concrete $X_{vcr} = 1.0$

Table 4b - Concrete compressive strength effect, shear, X_{vc}

f'_c (MPa)	20	25	32	40	50
X_{vc}	0.79	0.86	1.0	1.11	1.22

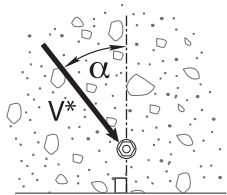

Load direction effect, conc. edge shear, X_{vd}

Table 4c - Concrete load direction effect, concrete edge shear, X_{vd}

Angle, α°	0-55	60	70	80	90-180
X_{vd}	1	1.1	1.2	1.5	2

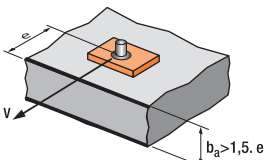

$$X_{ve} = e/e_m * \sqrt{e/e_m}$$

Table 4d - Concrete anchor spacing and edge distance effect, concrete edge shear, X_{ve}

For single anchor fastening X_{ve}

e/e_m	1.0	1.2	1.4	1.6	1.8	2.0	2.2	2.4	2.6	2.8	3.0	3.2
X_{ve}	1.00	1.31	1.66	2.02	2.41	2.83	3.26	3.72	4.19	4.69	5.20	5.72

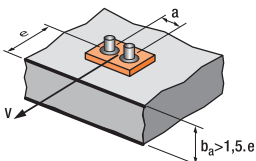

$$X_{ve} = \frac{3*e+a}{6*e_m} * \sqrt{e/e_m}$$

For 2 anchors fastening X_{ve}

e/e_m	1.0	1.2	1.4	1.6	1.8	2.0	2.2	2.4	2.6	2.8	3.0	3.2
a/e_m												
1.0	0.67	0.84	1.03	1.22	1.43	1.65	1.88	2.12	2.36	2.62	2.89	3.16
1.5	0.75	0.93	1.12	1.33	1.54	1.77	2.00	2.25	2.50	2.76	3.03	3.31
2.0	0.83	1.02	1.22	1.43	1.65	1.89	2.12	2.38	2.63	2.90	3.18	3.46
2.5	0.92	1.11	1.32	1.54	1.77	2.00	2.25	2.50	2.77	3.04	3.32	3.61
3.0	1.00	1.20	1.42	1.64	1.88	2.12	2.37	2.63	2.90	3.18	3.46	3.76
3.5		1.30	1.52	1.75	1.99	2.24	2.50	2.76	3.04	3.32	3.61	3.91
4.0			1.62	1.86	2.10	2.36	2.62	2.89	3.17	3.46	3.75	4.05
4.5				1.96	2.21	2.47	2.74	3.02	3.31	3.60	3.90	4.20
5.0					2.33	2.59	2.87	3.15	3.44	3.74	4.04	4.35
5.5						2.71	2.99	3.28	3.71	4.02	4.33	4.65
6.0						2.83	3.11	3.41	3.71	4.02	4.33	4.65

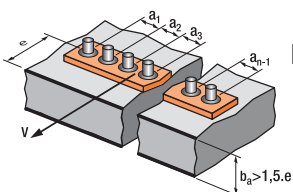

For 3 anchors fastening and more

$$X_{ve} = \frac{3*e + a_1 + a_2 + a_3 + \dots + a_{n-1}}{3*n*e_m} * \sqrt{e/e_m}$$

ChemSet™ 801 Xtrem™ XC²

STRENGTH LIMIT STATE DESIGN

Table 4e Reduced characteristic ultimate concrete pryout capacity, ϕV_{ucp} (kN), $\phi = 1/1.5 = 0.67$, $f'_c = 32$ MPa

Anchor size, d_b	M10	M12	M16	M20	M24	M30
Effective depth, h (mm)	90	110	125	170	210	280
-40 °C to +40 °C	56.5	82.9	108.9	156.7	211.1	288.4
-40 °C to +80 °C	52.8	77.4	100.5	142.4	190.0	271.4

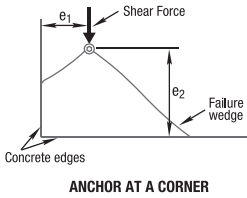

Table 4f Anchor at a corner effect, concrete edge shear, X_{vs}

Note: For $e_1/e_2 > 1.25$, $X_{vs} = 1.0$

Edge distance, e_2 (mm)	25	30	35	50	60	75	125	200	300	400	600	900
Edge distance, e_1 (mm)												
25	0.86	0.77	0.70	0.58	0.53	0.49	0.41	0.37	0.35	0.34	0.32	0.32
30	0.97	0.86	0.78	0.64	0.58	0.52	0.43	0.38	0.36	0.34	0.33	0.32
35	1.00	0.95	0.86	0.69	0.63	0.56	0.46	0.40	0.37	0.35	0.33	0.32
50	1.00	1.00	1.00	0.86	0.77	0.67	0.52	0.44	0.39	0.37	0.35	0.33
60	1.00	1.00	1.00	0.97	0.86	0.75	0.57	0.47	0.41	0.38	0.36	0.34
75	1.00	1.00	1.00	1.00	1.00	0.86	0.64	0.51	0.44	0.41	0.37	0.35
125	1.00	1.00	1.00	1.00	1.00	1.00	0.86	0.65	0.53	0.48	0.42	0.38
200	1.00	1.00	1.00	1.00	1.00	1.00	1.00	0.86	0.67	0.58	0.49	0.42
300	1.00	1.00	1.00	1.00	1.00	1.00	1.00	1.00	0.86	0.72	0.58	0.49
400	1.00	1.00	1.00	1.00	1.00	1.00	1.00	1.00	1.00	0.86	0.67	0.55
500	1.00	1.00	1.00	1.00	1.00	1.00	1.00	1.00	1.00	1.00	0.77	0.61
600	1.00	1.00	1.00	1.00	1.00	1.00	1.00	1.00	1.00	1.00	0.86	0.67
900	1.00	1.00	1.00	1.00	1.00	1.00	1.00	1.00	1.00	1.00	1.00	0.86

Checkpoint **4a**

Design reduced ultimate concrete edge shear capacity, ϕV_{urc}

$$\phi V_{urc} = \phi V_{uc} * X_{vcr} * X_{vc} * X_{vd} * X_{ve} * X_{vs}$$

Checkpoint **4b**

Design reduced ultimate concrete pryout capacity, ϕV_{urcp}

$$\phi V_{urcp} = \phi V_{ucp} * X_{ncr} * X_{nc} * X_{ne} * X_{na}$$

STEP **5**

Verify anchor shear capacity - per anchor

Table 5a Reduced characteristic ultimate steel shear capacity, ϕV_{us} (kN) where $\phi_v = 0.67$

Anchor size, d_b	M10	M12	M16	M20	M24	M30
ChemSet™ Anchor Stud Grade 5.8 Carbon Steel	11.8	17.5	33.1	49.9	72.3	-
ChemSet™ Anchor Stud A4/316 Stainless Steel	14.2	21.1	41.4	62.4	90.4	-
ChemSet™ Anchor Stud Grade 8.8 Carbon Steel	17.5	26.0	50.9	76.8	111.3	185.5

Checkpoint **5**

Design reduced ultimate shear capacity, ϕV_{ur}

$$\phi V_{ur} = \text{minimum of } \phi V_{urc}, \phi V_{urcp}, \phi V_{us}$$

Check $V/\phi V_{ur} \leq 1$,

if not satisfied return to step 1

ChemSet™ 801 Xtrem™ XC²

STRENGTH LIMIT STATE DESIGN

STEP 6 Combined Loading

Checkpoint 6

Check

$$N^*/\phi N_{ur} + V^*/\phi V_{ur} \leq 1.2,$$

if not satisfied return to step 1

Specify - Threaded Stud Anchors

Ramset™ 801 Xtrem™ XC² with (Anchor Size) grade 5.8 ChemSet™ Anchor Stud (Anchor Stud Part Number) Drilled Hole Depth to be (h) mm.

Example

Ramset™ 801 Xtrem™ XC² Injection with M16 grade 5.8 ChemSet™ Anchor Stud (CS16190GH). Drilled hole depth to be 125mm. To be installed according to Ramset™ Installation Instructions

Ramset™ iExpert Anchor Software for optimised calculation or where a greater range of anchor layout detail is needed.

ChemSet™ 101 PLUS

CHEMICAL INJECTION - NON-CRACKED CONCRETE

[Back to index](#)

GENERAL INFORMATION

Performance Related	Material Specification	Installation Related

Product

ChemSet™ Injection 101 PLUS is a marine grade polyester adhesive anchor.

Benefits, Advantages and Features

Design according to AS5216 (formerly TS101) and European design method EN1992-4 (formerly TR029)

- Certified Performance European Technical Assessment EAD 330499 - Option 7

Fast installation:

- Load in 50 minutes (at 20°C)
- Easy cold weather dispensing

Versatile:

- Suitable for anchoring into a wide variety of substrates
- Solid concrete, hollow block and brick
- Flooded holes
- Styrene Free
- Cold and temperate climates
- VOC Compliant

Australian Made

Installation

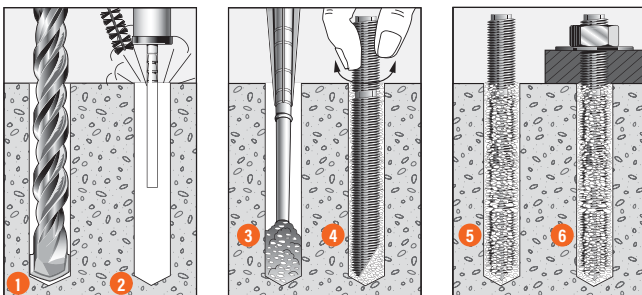

1. Drill recommended diameter and depth hole.
2. **Important:** Use **Ramset™** Dustless Drilling System to ensure holes are clean. Alternatively, clean dust and debris from hole with stiff wire or nylon brush and blower in the following sequence: blow x 4, brush x 3, blow x 4, brush x 3, blow x 4.
3. Dispense adhesive to waste until colour is uniform light grey (2-3 trigger pulls). Insert mixing nozzle to bottom of hole. Fill hole to 3/4 the hole depth slowly, ensuring no air pockets form.
4. Insert **Ramset™** ChemSet™ Anchor Stud/rebar to bottom of hole while turning.
5. ChemSet™ Injection to cure as per setting times.
6. Attach fixture.



Principal Applications

- Hollow brick and block
- Stadium seating
- Starter Bars
- Balustrades

Recommended Installation Temperatures

	Minimum	Maximum
Substrate	5°C	40°C
Adhesive	5°C	40°C

Service Temperature Limits

-40°C to 80°C

Setting Times

Temperature of base material	Cartridge Temperature	Gel Time	Curing time in dry and wet concrete
5°C	5°C	18 min	145 min
10°C	10°C	10 min	85 min
20°C	20°C	6 min	50 min
25°C	25°C	5 min	40 min
+30°C	+30°C	5 min	35 min

Note: Cartridge temperature minimum +5°C

ChemSet™ 101 PLUS

CHEMICAL INJECTION - NON-CRACKED CONCRETE

Installation and performance details: ChemSet™ 101 Plus and ChemSet™ Anchor Studs

Anchor size, d _b (mm)	Installation Details				Optimum dimensions*		
	Drilled hole diameter, d _h (mm)	Fixture hole diameter, d _f (mm)	Anchor effective depth, h (mm)	Tightening torque, T _r (Nm)	Edge distance, e _c (mm)	Anchor spacing, a _c (mm)	Concrete substrate thickness, b _m (mm)
M10	12	12	90	20	135	270	120
M12	14	14	110	40	165	330	140
M16	18	18	125	80	187	375	160
M20	22	22	170	150	255	510	220
M24	26	26	210	200	315	630	270

* Note: For shear loads acting towards an edge or where these optimum dimensions are not achievable, please use the simplified strength limit state design process to verify capacity.

Anchor size, d _b (mm)	Reduced Characteristic Capacity#								
	Grade 5.8 Steel Studs		Grade 8.8 Steel Studs		ANSI 316 Stainless Steel Studs		Non-Cracked Concrete		
	Shear, φV _{us} (kN)	Tension, φN _{us} (kN)***	Shear, φV _{us} (kN)	Tension, φN _{us} (kN)***	Shear, φV _{us} (kN)	Tension, φN _{us} (kN)***	Tension, φN _{uc} (kN)**		
							Concrete Compressive Strength, f' _c		
20-25 MPa			32-40 MPa			50 MPa			
M10	11.8	18.9	17.5	28.2	14.2	19.8	12.6	14.1	16.3
M12	17.5	28.1	26.0	41.9	21.1	29.5	20.7	23.2	27.0
M16	33.1	53.9	50.9	82.1	41.4	57.7	33.2	37.1	43.1
M20	49.9	81.3	76.8	123.9	62.4	87.1	50.4	56.5	65.6
M24	72.3	117.8	111.3	179.5	90.4	126.2	70.4	78.8	91.5

**Note: Reduced characteristic ultimate concrete tensile capacity = φN_{uc} where φ = 0.56 and N_{uc} = Characteristic ultimate concrete tensile capacity.

For conversion to Working Load Limit MULTIPLY φN_{uc} x 0.6

***Note: Reduced characteristic ultimate steel tensile capacity = φN_{us} where φ = 0.67 and N_{us} = Characteristic ultimate steel tensile capacity.

For conversion to Working Load Limit MULTIPLY φN_{us} x = 0.67 for Gr 5.8 & Gr 8.8

#Note: Design Tensile Capacity φN_{ur} = minimum of φN_{uc} and φN_{us}

For Cracked Concrete performance, please use the simplified strength limit state design process to verify capacity.

Data is based on a Service temperature limit of -40°C to +80°C

All data relevant for Non-Cracked Concrete, Dry, Wet and Flooded Holes

For optimised performance data, please use Ramset iExpert Anchoring Software.

DESCRIPTION AND PART NUMBERS

Description	Cartridge Size	Part No.
ChemSet™ 101 PLUS Cartridge	380 ml	C101C
ChemSet™ 101 PLUS Cartridge	750 ml	C101J
ChemSet™ 101 PLUS Kit	2 x 380 ml	ISKP
Mixer Nozzle for 101 PLUS	-	ISNP

ENGINEERING PROPERTIES

ChemSet™ Anchor Studs and Threaded Rod

Anchor Size, d _b	Grade 8.8 Threaded Rod				Stainless Steel High Corrosion Resistance HCR Grade 1.4529/1.4565 Threaded Rod				Section modulus Z (mm ³)
	Shank diameter, d _s (mm)	Stressed Area (mm ²)	Yield Strength f _y MPa	UTS f _u MPa	Shank diameter, d _s (mm)	Stressed Area (mm ²)	Yield Strength f _y MPa	UTS f _u MPa	
M10	8.6	58	640	800	8.2	52.8	450	650	62.3
M12	10.4	84.3	640	800	10	78.5	450	650	109.2
M16	14.1	157	640	800	14	153.9	450	650	277.5
M20	17.7	245	640	800	17.2	232.4	450	650	540.9
M24	21.2	353	640	800	20.7	336.5	450	650	935.5

Engineering Properties" for ChemSet™ Anchor Studs Grade 5.8 and AISI 316 Stainless Steel in the SARB ANZ on page 141.

ChemSet™ 101 PLUS

STRENGTH LIMIT STATE DESIGN

STEP 1 Select anchor to be evaluated

Table 1a Indicative combined loading - interaction diagram

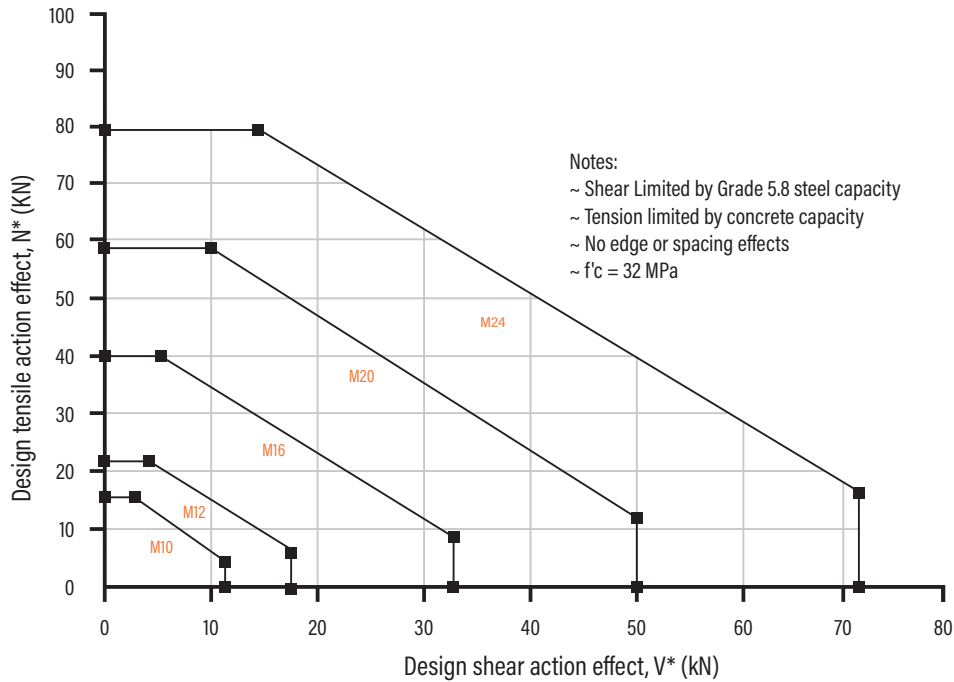

Table 1b Absolute minimum edge distance and anchor spacing values, e_m and a_m (mm)

Anchor size, d _s	M10	M12	M16	M20	M24
Min. Anchor Spacing - a _m	40	50	65	80	96
Min. Edge Distance - e _m	40	50	65	80	96

Step 1c Calculate anchor effective depth, h (mm)

Refer to "Description and Part Numbers" table for ChemSet Anchor Studs page in the SARB ANZ on page 141.

Effective depth, h (mm)

Preferred $h = h_n$ otherwise,

$h = L_e - t$

t = total thickness of material(s) being fastened.

Substrate thickness b _m (mm)				
Anchor Stud Size (mm)				
M10	M12	M16	M20	M24
h + 30mm ≥ 100mm			h + (2 x d _s)	

Checkpoint 1 Anchor size determined, absolute minima compliance achieved, effective depth (h) calculated.

ChemSet™ 101 PLUS

STRENGTH LIMIT STATE DESIGN

STEP

2

Verify concrete tensile capacity - per anchor

Table 2a Reduced characteristic ultimate concrete tensile capacity, ϕN_{uc} (kN), $\phi_c = 1/1.8 = 0.56$, $f'_c = 32$ MPa

Anchor Size, d_b	Combined pull-out and concrete cone resistance - ϕN_{ucp}				
	M10	M12	M16	M20	M24
Drilled Hole Dia, d_h (mm)	12	14	18	22	26
Effective Depth, h (mm)					
80	12.5				
85	13.3				
90	14.1				
100	15.6	21.1			
110	17.2	23.2			
120	18.8	25.3			
125		26.4	37.1		
140		29.6	41.6		
145		30.6	43.1		
160			47.5	53.2	
170			50.5	56.5	
180			53.5	59.8	
190			56.5	63.1	71.3
200				66.5	75.1
210				69.8	78.8
240				79.8	90.1
280					105.1
290					108.8

Bold values are at Chemset Anchor Stud nominal Depths

For Sustained Loads MULTIPLY ϕN_{uc} x 0.6

All data relevant for Non-Cracked Concrete, Dry, Wet and Flooded Holes

For optimised performance data, please use Ramset iExpert Anchoring Software.

Table 2b-1 Concrete service temperature limits effect, tension, X_{ns}

Service temperature (°C)	-40°C to +80°C
X_{ns}	1.00

Table 2b-2 Concrete compressive strength effect, tension, X_{nc}

f'_c (MPa)	20	25	32	40	50
X_{nc}	0.89	0.89	1.00	1.00	1.16

ChemSet™ 101 PLUS

STRENGTH LIMIT STATE DESIGN

Chemical Anchoring - Anchor Studs

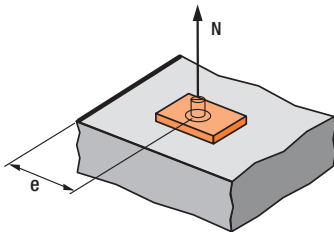

$$X_{ne} = 0.25 + 0.5 \cdot (e/h)$$

Where $e_m \leq e \leq e_c$

$$e_c = 1.5 \cdot h$$

Note: Tabled values are based on the nominal effective depth, h shown in the installation details. For other values of X_{ne} , please use equation shown above.

Table 2c - Concrete Edge distance effect, tension, X_{ne}

Anchor size, d_b	M10	M12	M16	M20	M24
Edge distance, e (mm)					
40	0.47				
50	0.53	0.48			
55	0.56	0.50			
65	0.61	0.54	0.51		
80	0.69	0.61	0.57	0.49	
90	0.75	0.66	0.61	0.51	
100	0.81	0.70	0.65	0.54	0.49
120	0.92	0.80	0.73	0.60	0.54
135	1	0.86	0.79	0.65	0.57
165		1	0.91	0.74	0.64
187			1	0.80	0.70
255				1	0.86
315					1

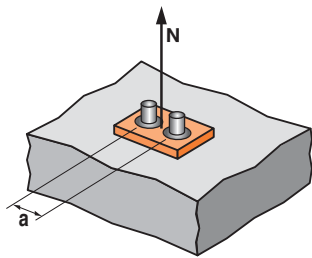

$$X_{na} = 0.5 + a/(6 \cdot h)$$

Where $a_m \leq a \leq a_c$

$$a_c = 3 \cdot h$$

Note: Tabled values are based on the nominal effective depth, h shown in the installation details. For other values X_{na} , please use equation shown above.

Table 2d - Concrete anchor spacing effect, tension, X_{na}

Anchor size, d_b	M10	M12	M16	M20	M24
Anchor spacing, a (mm)					
40	0.57				
50	0.59	0.57			
65	0.62	0.59	0.58		
80	0.64	0.62	0.60	0.57	
100	0.68	0.65	0.63	0.59	0.57
130	0.74	0.70	0.67	0.63	0.60
140	0.76	0.71	0.69	0.64	0.61
150	0.78	0.73	0.70	0.65	0.62
200	0.87	0.80	0.77	0.70	0.66
270	1	0.91	0.86	0.76	0.71
330		1	0.94	0.82	0.76
375			1	0.87	0.80
510				1	0.90
630					1

Checkpoint 2

Design reduced ultimate concrete tensile capacity, ϕN_{urc}

$$\phi N_{urc} = \phi N_{uc} \cdot X_{ns} \cdot X_{nc} \cdot X_{ne} \cdot X_{na}$$

STEP 3

Verify anchor tensile capacity - per anchor

Table 3a Reduced characteristic ultimate steel tensile capacity, ϕN_{us} (kN) where $\phi_n = 0.67$ for Gr 5.8 & Gr 8.8

Anchor size, d_b	M10	M12	M16	M20	M24
ChemSet™ Anchor Stud Grade 5.8 Carbon Steel	18.9	28.1	53.9	81.3	117.8
ChemSet™ Anchor Stud A4/316 Stainless Steel	19.8	29.5	57.7	87.1	126.2
ChemSet™ Anchor Stud Grade 8.8 Carbon Steel	28.2	41.9	82.1	123.9	179.5

Note: $\phi_n = 0.58$ for ChemSet™ Anchor Stud A4/316 Stainless Steel

Checkpoint 3

Design reduced ultimate tensile capacity, ϕN_{ur}

$$\phi N_{ur} = \text{minimum of } \phi N_{urc}, \phi N_{us}$$

Check $N^*/\phi N_{ur} \leq 1.0$,

if not satisfied return to step 1

ChemSet™ 101 PLUS

STRENGTH LIMIT STATE DESIGN

STEP 4

Step 4 - Verify concrete shear capacity - per anchor

Table 4a Reduced characteristic ultimate concrete edge shear capacity, ϕV_{uc} (kN), $\phi = 1/1.5 = 0.67$, $f'_c = 32$ MPa

Anchor size, d_b	M10	M12	M16	M20	M24
Effective depth, h (mm)	80 - 120	100 - 145	125 - 190	160 - 240	190 - 290
Edge distance, e_m					
40	4.4				
50		6.4			
65			10.0		
80				14.5	
100					20.8

For optimised performance data, please use Ramset iExpert Anchoring Software.

Table 4b - Concrete compressive strength effect, shear, X_{vc}

f'_c (MPa)	20	25	32	40	50
X_{vc}	0.79	0.86	1.0	1.11	1.22

Table 4c - Concrete load direction effect, concrete edge shear, X_{vd}

Angle, α°	0-55	60	70	80	90-180
X_{vd}	1	1.1	1.2	1.5	2

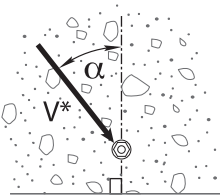

Load direction effect, conc. edge shear, X_{vd}

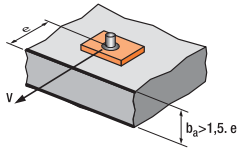

$$X_{ve} = e/e_m * \sqrt{e/e_m}$$

Table 4d - Concrete anchor spacing and edge distance effect, concrete edge shear, X_{ve}

For single anchor fastening X_{ve}

e/e_m	1.0	1.2	1.4	1.6	1.8	2.0	2.2	2.4	2.6	2.8	3.0	3.2
X_{ve}	1.00	1.31	1.66	2.02	2.41	2.83	3.26	3.72	4.19	4.69	5.20	5.72

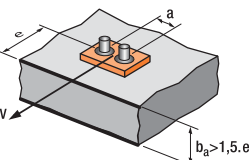

$$X_{ve} = \frac{3 * e + a}{6 * e_m} * \sqrt{e/e_m}$$

For 2 anchors fastening X_{ve}

e/e_m	1.0	1.2	1.4	1.6	1.8	2.0	2.2	2.4	2.6	2.8	3.0	3.2
a/e_m												
1.0	0.67	0.84	1.03	1.22	1.43	1.65	1.88	2.12	2.36	2.62	2.89	3.16
1.5	0.75	0.93	1.12	1.33	1.54	1.77	2.00	2.25	2.50	2.76	3.03	3.31
2.0	0.83	1.02	1.22	1.43	1.65	1.89	2.12	2.38	2.63	2.90	3.18	3.46
2.5	0.92	1.11	1.32	1.54	1.77	2.00	2.25	2.50	2.77	3.04	3.32	3.61
3.0	1.00	1.20	1.42	1.64	1.88	2.12	2.37	2.63	2.90	3.18	3.46	3.76
3.5		1.30	1.52	1.75	1.99	2.24	2.50	2.76	3.04	3.32	3.61	3.91
4.0			1.62	1.86	2.10	2.36	2.62	2.89	3.17	3.46	3.75	4.05
4.5				1.96	2.21	2.47	2.74	3.02	3.31	3.60	3.90	4.20
5.0					2.33	2.59	2.87	3.15	3.44	3.74	4.04	4.35
5.5						2.71	2.99	3.28	3.71	4.02	4.33	4.65
6.0						2.83	3.11	3.41	3.71	4.02	4.33	4.65

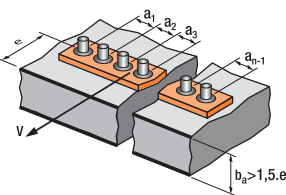

For 3 anchors fastening and more

$$X_{ve} = \frac{3 * e + a_1 + a_2 + a_3 + \dots + a_{n-1}}{3 * n * e_m} * \sqrt{e/e_m}$$

ChemSet™ 101 PLUS

STRENGTH LIMIT STATE DESIGN

Table 4e Reduced characteristic ultimate concrete pryout capacity, ϕV_{ucp} (kN), $\phi = 1/1.5 = 0.67$, $f'_c = 32$ MPa

Anchor size, d_b	M10	M12	M16	M20	M24
Effective depth, h (mm)	90	110	125	170	210
-40 °C to +80 °C	33.8	55.7	89.1	135.6	189.2

Table 4f Anchor at a corner effect, concrete edge shear, X_{vs}

Note: For $e_1/e_2 > 1.25$, $X_{vs} = 1.0$

Edge distance, e_2 (mm)	25	30	35	50	60	75	125	200	300	400	600	900
Edge distance, e_1 (mm)												
25	0.86	0.77	0.70	0.58	0.53	0.49	0.41	0.37	0.35	0.34	0.32	0.32
30	0.97	0.86	0.78	0.64	0.58	0.52	0.43	0.38	0.36	0.34	0.33	0.32
35	1.00	0.95	0.86	0.69	0.63	0.56	0.46	0.40	0.37	0.35	0.33	0.32
50	1.00	1.00	1.00	0.86	0.77	0.67	0.52	0.44	0.39	0.37	0.35	0.33
60	1.00	1.00	1.00	0.97	0.86	0.75	0.57	0.47	0.41	0.38	0.36	0.34
75	1.00	1.00	1.00	1.00	1.00	0.86	0.64	0.51	0.44	0.41	0.37	0.35
125	1.00	1.00	1.00	1.00	1.00	1.00	0.86	0.65	0.53	0.48	0.42	0.38
200	1.00	1.00	1.00	1.00	1.00	1.00	1.00	0.86	0.67	0.58	0.49	0.42
300	1.00	1.00	1.00	1.00	1.00	1.00	1.00	1.00	0.86	0.72	0.58	0.49
400	1.00	1.00	1.00	1.00	1.00	1.00	1.00	1.00	1.00	0.86	0.67	0.55
500	1.00	1.00	1.00	1.00	1.00	1.00	1.00	1.00	1.00	1.00	0.77	0.61
600	1.00	1.00	1.00	1.00	1.00	1.00	1.00	1.00	1.00	1.00	0.86	0.67
900	1.00	1.00	1.00	1.00	1.00	1.00	1.00	1.00	1.00	1.00	1.00	0.86

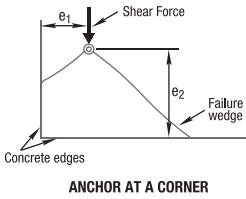

Checkpoint **4a**

Design reduced ultimate concrete edge shear capacity, ϕV_{urc}

$$\phi V_{urc} = \phi V_{uc} * X_{vc} * X_{vd} * X_{ve} * X_{vs}$$

Checkpoint **4b**

Design reduced ultimate concrete pryout capacity, ϕV_{urcp}

$$\phi V_{urcp} = \phi V_{ucp} * X_{nc} * X_{ne} * X_{na}$$

STEP **5**

Verify anchor shear capacity - per anchor

Table 5a Reduced characteristic ultimate steel shear capacity, ϕV_{us} (kN) where $\phi_v = 0.67$

Anchor size, d_b	M10	M12	M16	M20	M24
ChemSet™ Anchor Stud Grade 5.8 Carbon Steel	11.8	17.5	33.1	49.9	72.3
ChemSet™ Anchor Stud A4/316 Stainless Steel	14.2	21.1	41.4	62.4	90.4
ChemSet™ Anchor Stud Grade 8.8 Carbon Steel	17.5	26.0	50.9	76.8	111.3

Checkpoint **5**

Design reduced ultimate shear capacity, ϕV_{ur}

$$\phi V_{ur} = \text{minimum of } \phi V_{urc}, \phi V_{urcp}, \phi V_{us}$$

Check $V^*/\phi V_{ur} \leq 1.0$,
if not satisfied return to step 1

ChemSet™ 101 PLUS

STRENGTH LIMIT STATE DESIGN

STEP 6 Combined Loading

Checkpoint 6

Check

$N^*/\phi N_{ur} + V^*/\phi V_{ur} \leq 1.2$,
if not satisfied return to step 1

Specify - Threaded Stud Anchors
Ramset™ ChemSet™ 101 PLUS with (Anchor
Size) grade 5.8 ChemSet™ Anchor Stud
(Anchor Stud Part Number) Drilled Hole
Depth to be
(h) mm.

Example
Ramset™ ChemSet™ 101 PLUS Injection
with M16 grade 5.8 ChemSet™ Anchor
Stud (CS16190GH). Drilled hole depth to
be 125mm. To be installed according to
Ramset™ Installation Instructions.

Ramset™ iExpert Anchor Software for optimised calculation or where a greater range of anchor layout detail is needed.

ChemSet™ Maxima™

SPIN CAPSULES - NON-CRACKED CONCRETE

[Back to index](#)

Chemical Anchoring - Anchor Studs

GENERAL INFORMATION

Performance Related	Material Specification	Installation Related

Product

ChemSet™ Maxima™ Spin Capsule is a heavy duty, acrylic capsule anchor.

Benefits, Advantages and Features

Design according to AS5216 (formerly TS101) and European design method EN1992-4 (formerly TR029)

Certified Performance

European Technical Assessment EAD 330499 - Option 7.

No measuring, no mess, no waste:

- Adhesive is contained in pre-measured capsules.

Versatile:

- Use in damp or flooded holes or even underwater.

Fast installation:

- Cures in minutes and can be loaded in 20 min (at 20°C).

High bond strength:

- Acrylic adhesive.

High corrosion resistance:

(See page 20 and 21.)

Rated for Sustained Loading

VOC Compliant

Installation

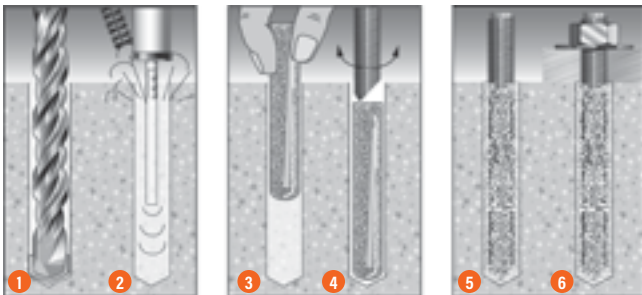

1. Drill recommended diameter and depth hole.
2. **Important:** Use **Ramset™** Dustless Drilling System to ensure holes are clean. Alternatively, clean dust and debris from hole with stiff wire or nylon brush and blower in the following sequence: blow x 4, brush x 3, blow x 4, brush x 3, blow x 4.
3. Insert correct size Spin capsule into the hole.
4. Using appropriate driver accessories, drive the ChemSet™ Anchor Stud into the hole using a hammer drill (on rotation).
5. Cure as per setting times.
6. Attach fixture and tighten nut in accordance with recommended tightening torque.



Principal Applications

- Structural steel
- Machine hold down
- Factory fit out
- Fencing
- Stadium seating
- Balustrades
- Signs
- Applications requiring a set number of fixings

Recommended Installation Temperatures

	Minimum	Maximum
Substrate	0°C	35°C

Service Temperature Limits

-40°C to 80°C

Setting Times

Temperature of base material	Curing time in dry concrete	Curing time in wet concrete
≥ +0°C	5 h	10 h
≥ +5°C	1 h	2 h
≥ +20°C	20 min	40 min
≥ +30°C	10 min	20 min

ChemSet™ Maxima™

SPIN CAPSULES - NON-CRACKED CONCRETE

Installation and performance details: ChemSet™ Maxima™ and ChemSet™ Anchor Studs

Anchor size, d _b (mm)	Installation Details				Optimum dimensions*		
	Drilled hole diameter, d _h (mm)	Fixture hole diameter, d _f (mm)	Anchor effective depth, h (mm)	Tightening torque, T _r (Nm)	Edge distance, e _c (mm)	Anchor spacing, a _c (mm)	Concrete substrate thickness, b _m (mm)
M10	12	12	90	20	135	270	120
M12	14	14	110	40	165	330	140
M16	18	18	125	80	187	375	160
M20	22	22	170	120	255	510	220
M24	26	26	210	180	315	630	270

* Note: For shear loads acting towards an edge or where these optimum dimensions are not achievable, please use the simplified strength limit state design process to verify capacity.

Anchor size, d _b (mm)	Reduced Characteristic Capacity#								
	Grade 5.8 Steel Studs		Grade 8.8 Steel Studs		ANSI 316 Stainless Steel Studs		Non-Cracked Concrete		
	Shear, φV _{us} (kN)	Tension, φN _{us} (kN)***	Shear, φV _{us} (kN)	Tension, φN _{us} (kN)***	Shear, φV _{us} (kN)	Tension, φN _{us} (kN)***	Tension, φN _{uc} (kN)**		
							Concrete Compressive Strength, f _c		
						20 MPa	32 MPa	40 MPa	
M10	11.8	18.9	17.5	28.2	14.2	19.8	18.8	21.5	23.8
M12	17.5	28.1	26.0	41.9	21.1	29.5	27.6	31.5	34.8
M16	33.1	53.9	50.9	82.1	41.4	57.7	41.9	47.8	52.8
M20	49.9	81.3	76.8	123.9	62.4	87.1	67.6	77.1	85.2
M24	72.3	117.8	111.3	179.5	90.4	126.2	100.3	114.3	126.4

**Note: Reduced characteristic ultimate concrete tensile capacity = φN_{uc} where φ = 0.67 and N_{uc} = Characteristic ultimate concrete tensile capacity.

For conversion to Working Load Limit MULTIPLY φN_{uc} x 0.5

***Note: Reduced characteristic ultimate steel tensile capacity = φN_{us} where φ = 0.67 and N_{us} = Characteristic ultimate steel tensile capacity.

For conversion to Working Load Limit MULTIPLY φN_{us} x = 0.67 for Gr 5.8 & Gr 8.8

#Note: Design Tensile Capacity φN_{ur} = minimum of φN_{uc} and φN_{us}

For Cracked Concrete performance, please use the simplified strength limit state design process to verify capacity.

Data is based on a Service temperature limit of -40°C to +80°C

All data relevant for Non-Cracked Concrete - DO NOT USE IN FLOODED HOLES

For optimised performance data, please use Ramset iExpert Anchoring Software.

DESCRIPTION AND PART NUMBERS

Capsule Dimensions (mm)		To suit ChemSet™ Anchor Stud		Capsule Part No.
Capsule Dimensions (mm)	Capsule length, L	Anchor Size, d _b	Effective depth, h (mm)	
11	80	M10	90	CHEM10
13	95	M12	110	CHEM12
17	95	M16	125	CHEM16
21.5	115	M20	150	CHEM2024
21.5	115	M24	160	CHEM2024

ENGINEERING PROPERTIES

ChemSet™ Anchor Studs and Threaded Rod

Anchor Size, d _b	Grade 8.8 Threaded Rod				Stainless Steel High Corrosion Resistance HCR Grade 1.4529/1.4565 Threaded Rod				Section modulus Z (mm ³)
	Shank diameter, d _s (mm)	Stressed Area (mm ²)	Yield Strength f _y MPa	UTS f _u MPa	Shank diameter, d _s (mm)	Stressed Area (mm ²)	Yield Strength f _y MPa	UTS f _u MPa	
M10	8.6	58	640	800	8.2	52.8	450	650	62.3
M12	10.4	84.3	640	800	10	78.5	450	650	109.2
M16	14.1	157	640	800	14	153.9	450	650	277.5
M20	17.7	245	640	800	17.2	232.4	450	650	540.9
M24	21.2	353	640	800	20.7	336.5	450	650	935.5

Engineering Properties* for ChemSet™ Anchor Studs Grade 5.8 and AISI 316 Stainless Steel in the SARB ANZ on page 141.

ChemSet™ Maxima™

STRENGTH LIMIT STATE DESIGN

STEP 1 Select anchor to be evaluated

Table 1a Indicative combined loading - interaction diagram

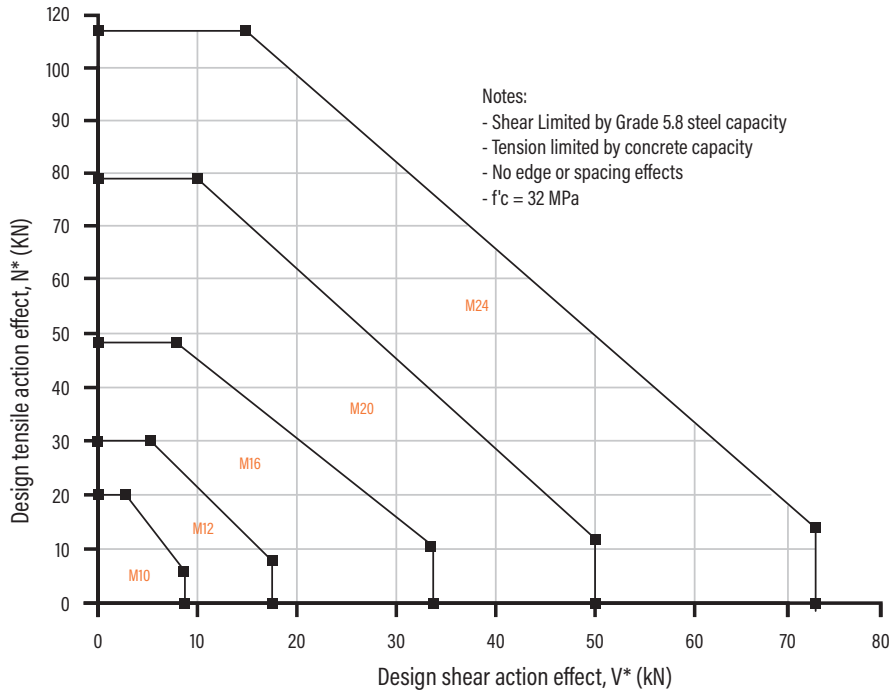

Table 1b Absolute minimum edge distance and anchor spacing values, e_m and a_m (mm)

Anchor size, d _s	M10	M12	M16	M20	M24
Min. Anchor Spacing - a _m	45	55	65	85	105
Min. Edge Distance - e _m	45	55	65	85	105

Step 1c Calculate anchor effective depth, h (mm)

Refer to "Description and Part Numbers" table for ChemSet Anchor Studs page in the SARB ANZ on page 141.

Checkpoint 1 Anchor size determined, absolute minima compliance achieved, effective depth (h) calculated.

ChemSet™ Maxima™

STRENGTH LIMIT STATE DESIGN

STEP 2 Verify concrete tensile capacity - per anchor

Table 2a Reduced characteristic ultimate concrete tensile capacity, ϕN_{uc} (kN), $\phi_c = 1/1.5 = 0.67$, $f'_c = 32$ MPa

Anchor Size, d_b	Combined pull-out and concrete cone resistance - ϕN_{ucp}				
	M10	M12	M16	M20	M24
Drilled Hole Dia, d_h (mm)	12	14	18	22	26
Effective Depth, h (mm)					
90	21.5				
110		31.5			
125			47.8		
170				77.1	
210					114.3

For Sustained Loads MULTIPLY ϕN_{uc} x 0.6

All data relevant for Non-Cracked Concrete

DO NOT USE IN FLOODED HOLES

For optimised performance data, please use Ramset iExpert Anchoring Software.

Table 2b-1 Concrete service temperature limits effect, tension, X_{ns}

Service temperature (°C)	-40°C to +80°C
X_{ns}	1.00

Table 2b-2 Concrete compressive strength effect, tension, X_{nc}

f'_c (MPa)	20	25	32	40	50
X_{nc}	0.88	0.93	1.00	1.11	1.18

ChemSet™ Maxima™

STRENGTH LIMIT STATE DESIGN

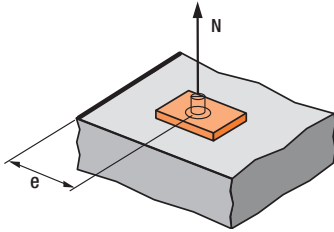

$X_{ne} = 0.25 + 0.5*(e/h)$
 Where $e_m \leq e \leq e_c$
 $e_c = 1.5*h$
 Note: Tabled values are based on the nominal effective depth, h shown in the installation details. For other values of X_{ne} , please use equation shown above.

Table 2c - Concrete Edge distance effect, tension, X_{ne}

Anchor size, d_b	M10	M12	M16	M20	M24
Edge distance, e (mm)					
45	0.50				
50	0.53				
55	0.56	0.50			
65	0.61	0.54	0.51		
85	0.72	0.63	0.59	0.50	
90	0.75	0.66	0.61	0.51	
105	0.83	0.72	0.67	0.55	0.50
120	0.92	0.80	0.73	0.60	0.54
135	1	0.86	0.79	0.65	0.57
165		1	0.91	0.74	0.64
187			1	0.80	0.70
255				1	0.86
315					1
420					

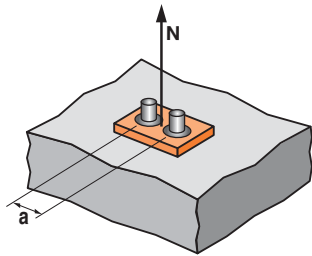

$X_{na} = 0.5 + a/(6*h)$
 Where $a_m \leq a \leq a_c$
 $a_c = 3*h$
 Note: Tabled values are based on the nominal effective depth, h shown in the installation details. For other values X_{na} , please use equation shown above.

Table 2d - Concrete anchor spacing effect, tension, X_{na}

Anchor size, d_b	M10	M12	M16	M20	M24
Anchor spacing, a (mm)					
45	0.58				
55	0.60	0.58			
65	0.62	0.59	0.58		
85	0.65	0.62	0.61	0.58	
105	0.69	0.65	0.64	0.60	0.58
130	0.74	0.70	0.67	0.63	0.60
140	0.76	0.71	0.69	0.64	0.61
150	0.78	0.73	0.70	0.65	0.62
200	0.87	0.80	0.77	0.70	0.66
270	1	0.91	0.86	0.76	0.71
330		1	0.94	0.82	0.76
375			1	0.87	0.80
510				1	0.90
630					1

Checkpoint 2

Design reduced ultimate concrete tensile capacity, ϕN_{urc}
 $\phi N_{urc} = \phi N_{uc} * X_{ns} * X_{nc} * X_{ne} * X_{na}$

STEP 3

Verify anchor shear capacity - per anchor

Table 3a Reduced characteristic ultimate steel tensile capacity, ϕN_{us} (kN) where $\phi_n = 0.67$ for Gr 5.8 & Gr 8.8

Anchor size, d_b	M10	M12	M16	M20	M24
ChemSet™ Anchor Stud Grade 5.8 Carbon Steel	18.9	28.1	53.9	81.3	117.8
ChemSet™ Anchor Stud A4/316 Stainless Steel	19.8	29.5	57.7	87.1	126.2
ChemSet™ Anchor Stud Grade 8.8 Carbon Steel	28.2	41.9	82.1	123.9	179.5

Note: $\phi_n = 0.58$ for ChemSet™ Anchor Stud A4/316 Stainless Steel

Checkpoint 3

Design reduced ultimate tensile capacity, ϕN_{ur}
 $\phi N_{ur} = \text{minimum of } \phi N_{urc}, \phi N_{us}$
 Check $N^*/\phi N_{ur} \leq 1.0$,
 if not satisfied return to step 1

ChemSet™ Maxima™

STRENGTH LIMIT STATE DESIGN

STEP 4

Step 4 - Verify concrete shear capacity - per anchor

Table 4a Reduced characteristic ultimate concrete edge shear capacity, ϕV_{uc} (kN), $\phi = 1/1.5 = 0.67$, $f'_c = 32$ MPa

Anchor size, d_b	M10	M12	M16	M20	M24
Effective depth, h (mm)	90	110	125	170	210
Edge distance, e_m					
45	5.3				
55		7.4			
65			10.0		
85				15.6	
105					22.7

For optimised performance data, please use Ramset iExpert Anchoring Software.

Table 4b - Concrete compressive strength effect, shear, X_{vc}

f'_c (MPa)	20	25	32	40	50
X_{vc}	0.79	0.86	1.0	1.11	1.22

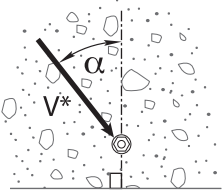

Load direction effect, conc. edge shear, X_{vd}

Table 4c - Concrete load direction effect, concrete edge shear, X_{vd}

Angle, α°	0-55	60	70	80	90-180
X_{vd}	1	1.1	1.2	1.5	2

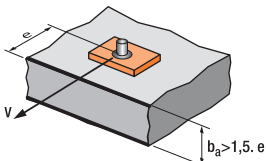

$$X_{ve} = e/e_m * \sqrt{e/e_m}$$

Table 4d - Concrete anchor spacing and edge distance effect, concrete edge shear, X_{ve}

For single anchor fastening X_{ve}

e/e_m	1.0	1.2	1.4	1.6	1.8	2.0	2.2	2.4	2.6	2.8	3.0	3.2
X_{ve}	1.00	1.31	1.66	2.02	2.41	2.83	3.26	3.72	4.19	4.69	5.20	5.72

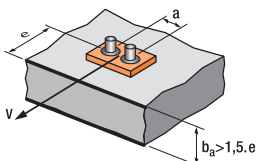

$$X_{ve} = \frac{3*e+a}{6*e_m} * \sqrt{e/e_m}$$

For 2 anchors fastening X_{ve}

e/e_m	1.0	1.2	1.4	1.6	1.8	2.0	2.2	2.4	2.6	2.8	3.0	3.2
a/e_m												
1.0	0.67	0.84	1.03	1.22	1.43	1.65	1.88	2.12	2.36	2.62	2.89	3.16
1.5	0.75	0.93	1.12	1.33	1.54	1.77	2.00	2.25	2.50	2.76	3.03	3.31
2.0	0.83	1.02	1.22	1.43	1.65	1.89	2.12	2.38	2.63	2.90	3.18	3.46
2.5	0.92	1.11	1.32	1.54	1.77	2.00	2.25	2.50	2.77	3.04	3.32	3.61
3.0	1.00	1.20	1.42	1.64	1.88	2.12	2.37	2.63	2.90	3.18	3.46	3.76
3.5		1.30	1.52	1.75	1.99	2.24	2.50	2.76	3.04	3.32	3.61	3.91
4.0			1.62	1.86	2.10	2.36	2.62	2.89	3.17	3.46	3.75	4.05
4.5				1.96	2.21	2.47	2.74	3.02	3.31	3.60	3.90	4.20
5.0					2.33	2.59	2.87	3.15	3.44	3.74	4.04	4.35
5.5						2.71	2.99	3.28	3.71	4.02	4.33	4.65
6.0							2.83	3.11	3.41	3.71	4.02	4.33

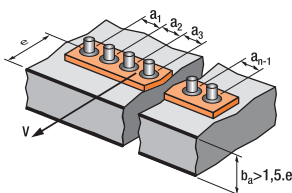

For 3 anchors fastening and more

$$X_{ve} = \frac{3*e + a_1 + a_2 + a_3 + \dots + a_{n-1}}{3*n*e_m} * \sqrt{e/e_m}$$

ChemSet™ Maxima™

STRENGTH LIMIT STATE DESIGN

Table 4e Reduced characteristic ultimate concrete pryout capacity, ϕV_{ucp} (kN), $\phi = 1/1.5 = 0.67$, $f'_c = 32$ MPa

Anchor size, d_b	M10	M12	M16	M20	M24
Effective depth, h (mm)	90	110	125	170	210
-40 °C to +80 °C	43.0	63.0	95.5	154.2	228.6

Table 4f Anchor at a corner effect, concrete edge shear, X_{vs}

Note: For $e_1/e_2 > 1.25$, $X_{vs} = 1.0$

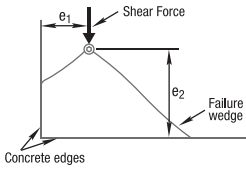

ANCHOR AT A CORNER

Edge distance, e_2 (mm)	25	30	35	50	60	75	125	200	300	400	600	900
Edge distance, e_1 (mm)												
25	0.86	0.77	0.70	0.58	0.53	0.49	0.41	0.37	0.35	0.34	0.32	0.32
30	0.97	0.86	0.78	0.64	0.58	0.52	0.43	0.38	0.36	0.34	0.33	0.32
35	1.00	0.95	0.86	0.69	0.63	0.56	0.46	0.40	0.37	0.35	0.33	0.32
50	1.00	1.00	1.00	0.86	0.77	0.67	0.52	0.44	0.39	0.37	0.35	0.33
60	1.00	1.00	1.00	0.97	0.86	0.75	0.57	0.47	0.41	0.38	0.36	0.34
75	1.00	1.00	1.00	1.00	1.00	0.86	0.64	0.51	0.44	0.41	0.37	0.35
125	1.00	1.00	1.00	1.00	1.00	1.00	0.86	0.65	0.53	0.48	0.42	0.38
200	1.00	1.00	1.00	1.00	1.00	1.00	1.00	0.86	0.67	0.58	0.49	0.42
300	1.00	1.00	1.00	1.00	1.00	1.00	1.00	1.00	0.86	0.72	0.58	0.49
400	1.00	1.00	1.00	1.00	1.00	1.00	1.00	1.00	1.00	0.86	0.67	0.55
500	1.00	1.00	1.00	1.00	1.00	1.00	1.00	1.00	1.00	1.00	0.77	0.61
600	1.00	1.00	1.00	1.00	1.00	1.00	1.00	1.00	1.00	1.00	0.86	0.67
900	1.00	1.00	1.00	1.00	1.00	1.00	1.00	1.00	1.00	1.00	1.00	0.86

Checkpoint 4a

Design reduced ultimate concrete edge shear capacity, ϕV_{urc}

$$\phi V_{urc} = \phi V_{uc} * X_{vc} * X_{vd} * X_{ve} * X_{vs}$$

Checkpoint 4b

Design reduced ultimate concrete pryout capacity, ϕV_{urcp}

$$\phi V_{urcp} = \phi V_{ucp} * X_{nc} * X_{ne} * X_{na}$$

STEP 5

Verify anchor shear capacity - per anchor

Table 5a Reduced characteristic ultimate steel shear capacity, ϕV_{us} (kN) where $\phi_v = 0.67$

Anchor size, d_b	M10	M12	M16	M20	M24
ChemSet™ Anchor Stud Grade 5.8 Carbon Steel	11.8	17.5	33.1	49.9	72.3
ChemSet™ Anchor Stud A4/316 Stainless Steel	14.2	21.1	41.4	62.4	90.4
ChemSet™ Anchor Stud Grade 8.8 Carbon Steel	17.5	26.0	50.9	76.8	111.3

Checkpoint 5

Design reduced ultimate shear capacity, ϕV_{ur}

$$\phi V_{ur} = \text{minimum of } \phi V_{urc}, \phi V_{urcp}, \phi V_{us}$$

Check $V^*/\phi V_{ur} \leq 1.0$,

if not satisfied return to step 1

ChemSet™ Maxima™

STRENGTH LIMIT STATE DESIGN

STEP 6 Combined Loading

Checkpoint 6

Check

$N^*/\phi N_{ur} + V^*/\phi V_{ur} \leq 1.2$,
if not satisfied return to step 1

Specify - Threaded Stud Anchors
Ramset™ Maxima with (Anchor Size) grade 5.8 ChemSet™ Anchor Stud (Anchor Stud Part Number) Drilled Hole Depth to be (h) mm.

Example
Ramset™ Maxima Spin Capsule with M16 grade 5.8 ChemSet™ Anchor Stud (CS16190GH). Drilled hole depth to be 125mm. To be installed according to Ramset™ Installation Instructions.

Introduction

CHEMICAL ANCHORING - THREADED INSERTS

[Back to index](#)

Chemical Anchoring Threaded Inserts

Introduction

The Ramset™ post-installed Threaded Insert system features a CAD optimised multicone design for high performance in shallow embedment depths. The system features an integrated splined segment to prevent rotation when torque is applied and a sealed centering cap to protect the internal thread from dust and resin.

The New Generation Threaded Inserts are available in High Performance Grade 5.8 Carbon Steel or AISI 316 Stainless Steel and are designed to be installed with the Fast curing ChemSet™ 801 Xtrem™, Epcon™ C6 PLUS or Extra Heavy Duty ChemSet™ Reo 502™ Plus chemical injection systems. By utilising a chemical injection system, material and labour costs can be reduced as well as reducing installation error. The optimised shallow embedment reduces the chance of drilling into rebar and maximises installation options in thin slab applications.

Ramset™ Threaded Inserts finish flush with the surface of the substrate, leaving no protrusions when not in use, making them ideal for removable or temporary applications. The Threaded Insert accepts metric machine bolts or threaded rod maximising design opportunities.

In addition, the ability to select architectural grade bolt heads makes Ramset™ Threaded Inserts ideal for facade and balustrade systems where aesthetics may be a specific requirement.

The key advantage of Ramset™ chemical anchoring is that it does not impact an expansion stress on the surrounding substrate. This makes chemical anchoring ideal for close to edge fixings or for close anchor spacing.

The ability of Ramset™ ChemSet™ Reo 502™ Plus, Epcon™ C6 PLUS and ChemSet™ 801 Xtrem™ XC² chemical anchoring to sustain cyclic tensile loads relies on adhesive bond, not on preload or tightening torque. The adhesive bond does not deteriorate or change over time making Ramset™ chemical anchors ideal for cyclic and vibrating load cases.

Threaded Inserts

CHEMICAL INJECTION - NON-CRACKED CONCRETE

GENERAL INFORMATION

Performance Related	Material Specification	Installation Related

Product

Threaded Inserts are internally threaded steel fixings and are installed using injection systems ChemSet[™] Reo 502[™] PLUS, Epcon[™] C6 PLUS or ChemSet[™] 801 Xtrem[™] XC². Once installed, any threaded bolt is used to secure the fixture to concrete.

Benefits, Advantages and Features

Suitable for structural loads:

- High Performance Grade 5.8 Carbon Steel.
- High Performance AISI 316 Stainless Steel for Coastal or fresh water applications.

Greater security:

- High loads in shallow holes in thin slabs.

Versatile:

- Anchor in dry, damp, wet and flooded holes.
- Anchors in carbide drilled and diamond cored holes.
- Zinc Plated for indoor or dry climates.
- Supplied with plastic cap to protect threads during installation.

Fast installation:

- Chemical Injection System
- Protective cap
- Shallow embedment depths

Ramset Design Method:

- Uses technical data validated from testing in ANZ concrete

Installation

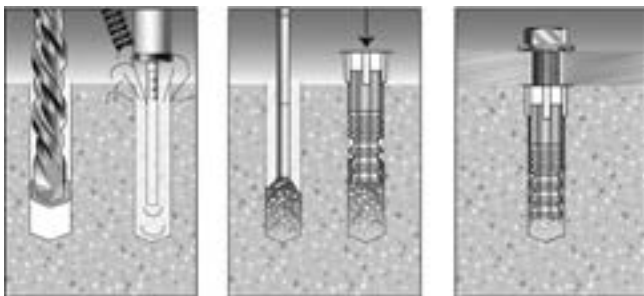

1. Drill or core hole to specified diameter and depth
2. **Important:** Use **Ramset[™] Dustless Drilling System** to ensure holes are clean. Alternatively, clean dust and debris from hole with stiff wire or nylon brush and blower in the following sequence: blow x 2, brush x 2, blow x 2, brush x 2, blow x 2.
3. Screw mixing nozzle onto cartridge and dispense 2-3 trigger pulls of adhesive to waste until colour is grey with no streaks
4. Insert tip of nozzle to bottom of hole and dispense adhesive
5. Fill hole to about 2/3 full
6. Insert threaded insert with rotating motion to release trapped air
7. Wait until adhesive has fully cured before loading (see Working Time / Loading Time chart for each adhesive)

Refer to **Technical Data Sheet** and **MSDS** available from www.ramset.com.au, for precautions and further detailed installation instructions

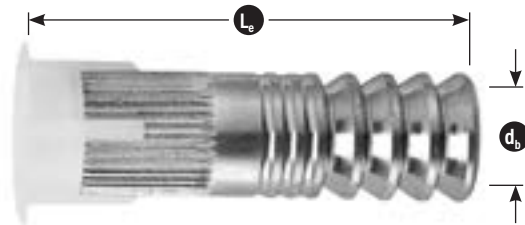

Principal Applications

- Machinery hold down
- Structural steel connections
- Seating
- Hand Rails
- Balustrade posts
- Removable fixings

Setting Times

ChemSet[™] Reo 502[™] PLUS (AUS ONLY)

Installation temperature limits:
 -Substrate: 5 °C to 40 °C
 -Adhesive: 10 °C to 40 °C

Load should not be applied to anchor until the chemical has sufficiently cured as specified
Service temperature limits:
 -40 °C to 70 °C

Temperature of base material	Cartridge Temperature	Gel Time	Curing time in dry and wet concrete
5°C	Minimum 10°C	300 min	24 h
10°C	10°C	150 min	18 h
15°C	15°C	40 min	12 h
20°C	20°C	25 min	8 h
25°C	25°C	18 min	6 h
30°C	30°C	12 min	4 h
40°C	40°C	6 min	2 h

Note: Cartridge temperature minimum +10°C

Epcon[™] C6 PLUS (NZ ONLY)

Installation temperature limits:
 -Substrate: 5 °C to 40 °C
 -Adhesive: 10 °C to 40 °C

Load should not be applied to anchor until the chemical has sufficiently cured as specified.
Service temperature limits:
 -40 °C to 70 °C

Temperature of base material	Cartridge Temperature	Gel Time	Curing time in dry and wet concrete
5°C	Minimum 10°C	300 min	24 h
10°C	10°C	150 min	18 h
15°C	15°C	40 min	12 h
20°C	20°C	25 min	8 h
25°C	25°C	18 min	6 h
30°C	30°C	12 min	4 h
40°C	40°C	6 min	2 h

Note: Cartridge temperature minimum +10°C

ChemSet[™] 801 Xtrem[™] XC²

Installation temperature limits:
 -Substrate: 5 °C to 40 °C
 -Adhesive: 5 °C to 40 °C

Load should not be applied to anchor until the chemical has sufficiently cured as specified
Service temperature limits:
 -40 °C to 80 °C

Temperature of base material	Gel Time	Curing time in dry concrete	Curing time in wet concrete
+5°C	60 min	240 min	480 min
6°C - 10°C	40 min	180 min	360 min
11°C - 20°C	15 min	120 min	240 min
21°C - 30°C	8 min	90 min	180 min
31°C - 40°C	4 min	60 min	120 min

Note: Cartridge temperature minimum +5°C

Threaded Inserts

CHEMICAL INJECTION - NON-CRACKED CONCRETE

Installation and performance details:
 Threaded Inserts with ChemSet™ Injection - Reo 502™ PLUS, Epcon™ C6 Plus and 801 Xtrem™ XC²

Anchor size, d _b (mm)	Installation details					Optimum dimensions		Concrete substrate thickness, b _m (mm)
	Drilled hole diam. , d _h (mm)	Fixture hole diameter, d _f (mm)	Anchor effective depth, h (mm)	Tightening torque, 5.8 A4 316 Bolt T _r (Nm)	Tightening torque, 8.8 grade Bolt T _r (Nm)	Anchor* spacing, a _c (mm)	Edge* distance, e _c (mm)	
M8	14	10	60	10	15	120	60	100
M10	20	12	65	22	30	130	65	100
M12	24	15	75	36	70	150	85	125
M16	28	20	125	80	120	250	125	180
M20	35	24	170	120	200	340	170	240

* For anchor spacings less than the optimum, please contact your local Ramset Engineer.

Anchor size, d _b (mm)	Reduced Characteristic Capacity#							
	Gr 5.8 Carbon Steel		Gr 316 Stainless Steel		Concrete			
	Threaded Insert Shear, φV _{us} (kN)	Threaded Insert Tension, φN _{us} (kN)***	Threaded Insert Shear, φV _{us} (kN)	Threaded Insert Tension, φN _{us} (kN)***	ChemSet™ Reo 502™ Plus & Epcon™ C6 Plus Tension, φN _{uc} (kN)**			ChemSet™ 801 Xtrem™ XC ² Tension, φN _{uc} (kN)**
					Concrete compressive strength, f' _c			Concrete compressive strength, f' _c
			20 MPa			25 MPa	≥ 32 MPa	≥ 20 MPa
M8	7.4	14.4	9.1	18.5	11.1	11.5	12.2	11.1
M10	11.6	23.2	14.9	29.6	16.2	16.8	17.8	16.2
M12	16.9	33.6	21.6	43.2	19.7	20.4	21.6	19.7
M16	31.2	62.4	40.8	81.5	51.0	53.0	56.1	51.0
M20	48.8	97.4	-	-	100.1	104.1	110.1	100.1

* Note: For shear loads acting towards an edge or where these optimum dimensions are not achievable, please use the simplified strength limit state design process to verify capacity.

**Note: Reduced characteristic ultimate concrete tensile capacity = φN_{uc} where φ = 0.6 and N_{uc} = Characteristic ultimate concrete tensile capacity.

For conversion to Working Load Limit MULTIPLY φN_{uc} x 0.55

***Note: Reduced characteristic ultimate steel tensile capacity = φN_{us} where φ = 0.8 and N_{us} = Characteristic ultimate steel tensile capacity.

For conversion to Working Load Limit MULTIPLY φN_{us} x 0.57

#Note: Design Tensile Capacity φN_{ut} = minimum of φN_{uc} and φN_{us}

All data relevant for Non-Cracked Concrete.

DESCRIPTION AND PART NUMBERS

Anchor size, d _b (mm)	Drilled hole diam. , d _h (mm)	Overall Length, L (mm)	Effective Length, L _e (mm)	Thread Length, L _t (mm)	Part Number	
					Zinc 5.8 grade	Stainless Steel AISI 316
M8	14	60	60	25	062770	062860
M10	20	65	65	32	062480	062960
M12	24	75	75	38	062760	063100
M16	28	125	125	50	062800	051175
M20	35	170	170	63	062810	-

ENGINEERING PROPERTIES

Anchor size, d _b	Carbon Steel		Stainless Steel	
	Yield Strength, f _{yk} (MPa)	Min. Tensile Strength, f _{uk} (MPa)	Yield Strength, f _{yk} (MPa)	Min. Tensile Strength, f _{uk} (MPa)
M8	420	520	350	650
M10	420	520	350	650
M12	420	520	350	650
M16	420	520	350	650
M20	420	520	-	-

Threaded Inserts

STRENGTH LIMIT STATE DESIGN

STEP 1 Select Anchor to be evaluated

Table 1a Indicative combined loading - interaction diagram

Table 1b Absolute minimum edge distance and anchor spacing values, e_m and a_m (mm)

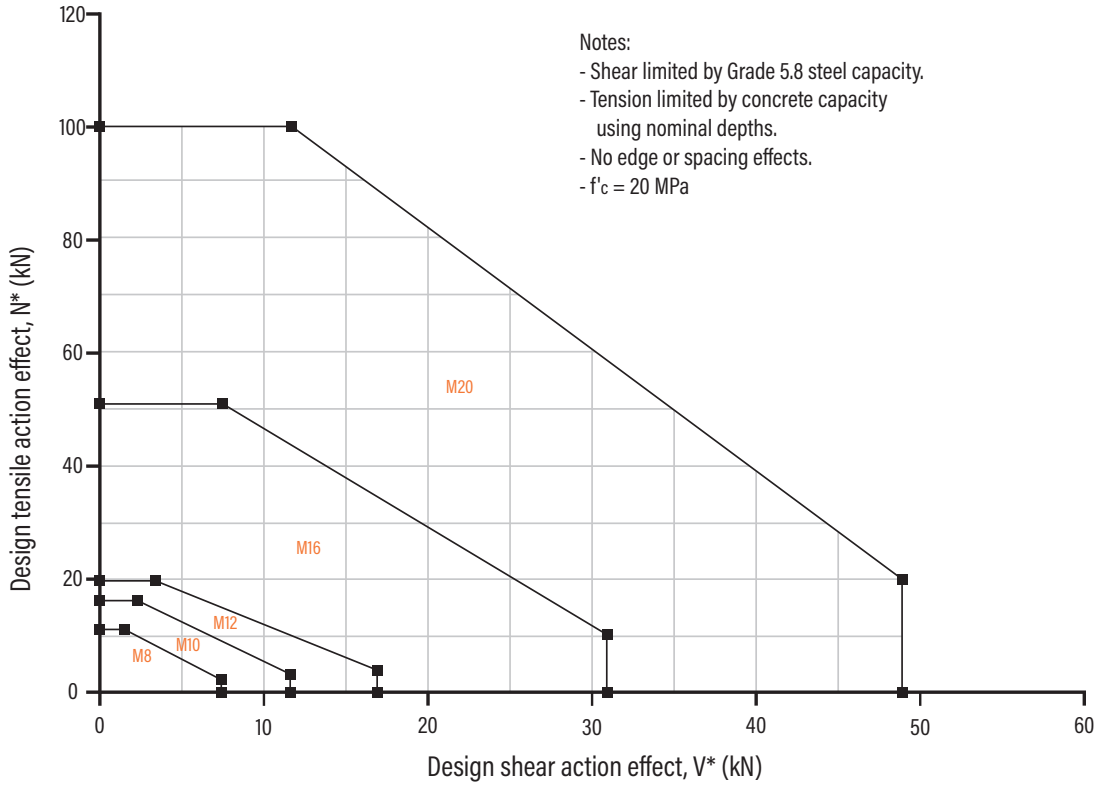

Anchor size, d_b	M8	M10	M12	M16	M20
Effective depth, h (mm)	60	65	75	125	170
e_m	40	45	55	65	85
a_m	40	45	55	65	85

Checkpoint 1 Anchor size determined, absolute minima compliance achieved, effective depth (h) calculated.

Threaded Inserts

STRENGTH LIMIT STATE DESIGN

STEP 2

Verify concrete tensile capacity - per anchor

Table 2a Reduced characteristic ultimate concrete tensile capacity, ϕN_{uc} (KN), $\phi_c = 0.6$, $f'_c = 20$ MPa

Anchor Size, d_b	M8	M10	M12	M16	M20
Drilled Hole Dia, d_h (mm)	14	20	24	28	35
Effective Depth, h (mm)					
60	11.1				
65		16.2			
75			19.7		
125				51.0	
170					100.1

NOTE: When Using ChemSet™ 801 Xtrem™ - WET HOLES: Multiply $\phi N_{uc} * 0.6$

When Using ChemSet™ Reo 502™ Plus and Epcon™ C6 Plus - WET HOLES: Multiply $\phi N_{uc} * 0.7$

Table 2b-1 Concrete service temperature limits effect, tension, X_{ns}

Anchor size, d_b	Epcon™ C6 PLUS	ChemSet™ Reo 502™ Plus	ChemSet™ 801 Xtrem™
Service temperature (°C)			
-40°C to +40°C	1.00	1.00	1.00
-40°C to +70°C	1.00	1.00	0.90
-40°C to +80°C	N/A	N/A	0.90

Table 2b-2 Concrete compressive strength effect, tension, X_{nc}

f'_c	20	25	32	40	50
801 Xtrem™ XC ² - X_{nc}	1	1	1	1	1
Reo 502 PLUS - X_{nc}	1	1.04	1.10	1.10	1.10
Epcon C6 PLUS - X_{nc}	1	1.04	1.10	1.10	1.10

Table 2c - Edge distance effect, tension, X_{ne}

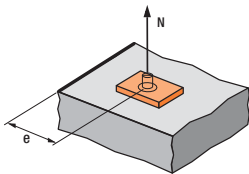

Anchor size, d_b	M8	M10	M12	M16	M20
Edge distance, e (mm)					
40	0.75				
45	0.81	0.77			
55	0.93	0.88	0.80		
65	1	1	0.90	0.65	0.55
85			1	0.76	0.63
90				0.79	0.65
100				0.85	0.70
125				1	0.80
150					0.91
170					1

Table 2d - Anchor spacing effect, tension, X_{na}

For single anchor design, $X_{na} = 1.0$

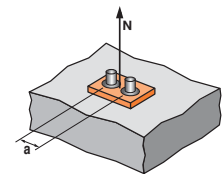

Anchor size, d_b	M8	M10	M12	M16	M20
Anchor spacing, a (mm)					
40	0.67				
45	0.69	0.67			
55	0.73	0.71	0.68		
65	0.77	0.75	0.72	0.63	
85	0.85	0.83	0.78	0.67	0.60
100	0.92	0.88	0.83	0.70	0.65
120	1	0.96	0.90	0.74	0.68
130		1	0.93	0.76	0.69
150			1	0.80	0.72
200				0.90	0.79
250				1	0.87
300					0.94
340					1

Checkpoint 2

Design reduced ultimate concrete tensile capacity, ϕN_{urc}

$$\phi N_{urc} = \phi N_{uc} * X_{ns} * X_{nc} * X_{ne} * X_{na}$$

Threaded Inserts

STRENGTH LIMIT STATE DESIGN

STEP 3

Verify anchor tensile capacity - per anchor

Table 3a - Reduced characteristic ultimate steel tensile capacity, ϕN_{us} (kN), $\phi_n = 0.8$

Anchor size, d_b	M8	M10	M12	M16	M20
Threaded Insert Grade 5.8 Carbon Steel	14.4	23.2	33.6	62.4	97.4
Threaded Insert A4/316 Stainless Steel	18.5	29.6	43.2	81.5	-

Step 3b - Reduced characteristic ultimate bolt steel tensile capacity, ϕN_{tf} (kN)

Establish the reduced characteristic ultimate bolt steel tensile capacity, ϕN_{tf} from literature supplied by the specified bolt manufacturer. For nominal expected capacities of bolts manufactured to ISO standards, refer to Pg 322

Checkpoint 3

Design reduced ultimate tensile capacity, ϕN_{ur}

$\phi N_{ur} = \text{minimum of } \phi N_{urc}, \phi N_{us}, \phi N_{tf}$

Check $N^* / \phi N_{ur} \leq 1$,

if not satisfied return to step 1

STEP 4

Verify concrete shear capacity - per anchor

Table 4a - Reduced characteristic ultimate concrete edge shear capacity, ϕV_{uc} (kN) $\phi_q = 0.6, f'_c = 20$ MPa

Anchor size, d_b	M8	M10	M12	M16	M20
Effective depth, h (mm)	60	65	75	125	170
Edge distance, e_m					
40	2.3				
45		3.1			
55			4.5		
65				6.6	
85					11.3

For optimised performance data, please use Ramset iExpert Anchoring Software.

Table 4b - Concrete compressive strength effect, shear, X_{vc}

f'_c (MPa)	20	25	32	40	50
X_{vc}	1	1	1.17	1.26	1.34

Table 4c - Load direction effect, concrete edge shear, X_{vd}

Angle, α°	0-55	60	70	80	90-180
X_{vd}	1	1.1	1.2	1.5	2

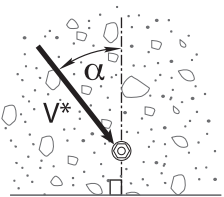

Load direction effect, conc. edge shear, X_{vd}

Threaded Inserts

STRENGTH LIMIT STATE DESIGN

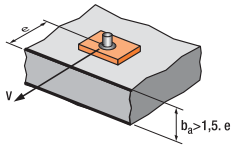

$$X_{ve} = e/e_m * \sqrt{e/e_m}$$

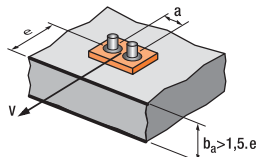

$$X_{ve} = \frac{3*e+a}{6*e_m} * \sqrt{e/e_m}$$

Table 4d - Anchor spacing and edge distance effect, concrete edge shear, X_{ve}

For single anchor fastening X_{ve}

e/e_m	1.0	1.2	1.4	1.6	1.8	2.0	2.2	2.4	2.6	2.8	3.0	3.2
X_{ve}	1.00	1.31	1.66	2.02	2.41	2.83	3.26	3.72	4.19	4.69	5.20	5.72

For 2 anchors fastening X_{ve}

e/e_m	1.0	1.2	1.4	1.6	1.8	2.0	2.2	2.4	2.6	2.8	3.0	3.2
a/e_m												
1.0	0.67	0.84	1.03	1.22	1.43	1.65	1.88	2.12	2.36	2.62	2.89	3.16
1.5	0.75	0.93	1.12	1.33	1.54	1.77	2.00	2.25	2.50	2.76	3.03	3.31
2.0	0.83	1.02	1.22	1.43	1.65	1.89	2.12	2.38	2.63	2.90	3.18	3.46
2.5	0.92	1.11	1.32	1.54	1.77	2.00	2.25	2.50	2.77	3.04	3.32	3.61
3.0	1.00	1.20	1.42	1.64	1.88	2.12	2.37	2.63	2.90	3.18	3.46	3.76
3.5		1.30	1.52	1.75	1.99	2.24	2.50	2.76	3.04	3.32	3.61	3.91
4.0			1.62	1.86	2.10	2.36	2.62	2.89	3.17	3.46	3.75	4.05
4.5				1.96	2.21	2.47	2.74	3.02	3.31	3.60	3.90	4.20
5.0					2.33	2.59	2.87	3.15	3.44	3.74	4.04	4.35
5.5						2.71	2.99	3.28	3.71	4.02	4.33	4.65
6.0						2.83	3.11	3.41	3.71	4.02	4.33	4.65

For 3 anchors fastening and more X_{ve}

$$X_{ve} = \frac{3*e + a_1 + a_2 + a_3 + \dots + a_{n-1}}{3*n*e_m} * \sqrt{e/e_m}$$

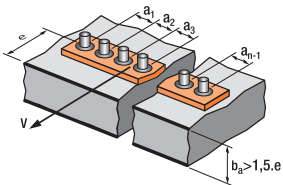
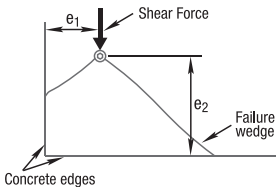

Table 4f Anchor at a corner effect, concrete edge shear, X_{vs}

Note: For $e_1/e_2 > 1.25$, $X_{vs} = 1.0$

Edge distance, e_2 (mm)	25	30	35	50	60	75	125	200	300	400	600	900
Edge distance, e_1 (mm)												
25	0.86	0.77	0.70	0.58	0.53	0.49	0.41	0.37	0.35	0.34	0.32	0.32
30	0.97	0.86	0.78	0.64	0.58	0.52	0.43	0.38	0.36	0.34	0.33	0.32
35	1.00	0.95	0.86	0.69	0.63	0.56	0.46	0.40	0.37	0.35	0.33	0.32
50	1.00	1.00	1.00	0.86	0.77	0.67	0.52	0.44	0.39	0.37	0.35	0.33
60	1.00	1.00	1.00	0.97	0.86	0.75	0.57	0.47	0.41	0.38	0.36	0.34
75	1.00	1.00	1.00	1.00	1.00	0.86	0.64	0.51	0.44	0.41	0.37	0.35
125	1.00	1.00	1.00	1.00	1.00	1.00	0.86	0.65	0.53	0.48	0.42	0.38
200	1.00	1.00	1.00	1.00	1.00	1.00	1.00	0.86	0.67	0.58	0.49	0.42
300	1.00	1.00	1.00	1.00	1.00	1.00	1.00	1.00	0.86	0.72	0.58	0.49
400	1.00	1.00	1.00	1.00	1.00	1.00	1.00	1.00	1.00	0.86	0.67	0.55
500	1.00	1.00	1.00	1.00	1.00	1.00	1.00	1.00	1.00	1.00	0.77	0.61
600	1.00	1.00	1.00	1.00	1.00	1.00	1.00	1.00	1.00	1.00	0.86	0.67
900	1.00	1.00	1.00	1.00	1.00	1.00	1.00	1.00	1.00	1.00	1.00	0.86



Checkpoint

4

Design reduced ultimate concrete edge shear capacity, ϕV_{urc}

$$\phi V_{urc} = \phi V_{uc} * X_{vc} * X_{vd} * X_{ve} * X_{vs}$$

Threaded Inserts

STRENGTH LIMIT STATE DESIGN

STEP 5 Verify anchor shear capacity - per anchor

Table 5a - Reduced characteristic ultimate steel shear capacity, ϕV_{us} (kN), $\phi_V = 0.8$

Anchor size, d_b	M8	M10	M12	M16	M20
Threaded Insert Grade 5.8 Carbon Steel	7.4	11.6	16.9	31.2	48.8
Threaded Insert A4/316 Stainless Steel	9.1	14.9	21.6	40.8	-

Step 5b - Reduced characteristic ultimate bolt steel shear capacity ϕV_{sf} (kN)

Establish the reduced characteristic ultimate bolt steel shear capacity, ϕV_{sf} from literature by the specified bolt manufacturer. For nominal expected capacities of bolts manufactured to ISO Standards, refer to page 322.

Checkpoint 5 Design reduced ultimate shear capacity, ϕV_{ur}
 $\phi V_{ur} = \text{minimum of } \phi V_{urc}, \phi V_{us}, \phi V_{sf}$
 Check $V^*/\phi V_{ur} \leq 1$,
 if not satisfied return to step 1

STEP 6 Combined loading

Checkpoint 6 Check $N^*/\phi N_{ur} + V^*/\phi V_{ur} \leq 1.2$,
 if not satisfied return to step 1

Specify
 Ramset™ Threaded Insert Chemical Injection
 Threaded Insert (Size) (Part number)
 Injection System (Type) (Part number)
 Maximum fixed thickness to be (t) mm.

Example
 Ramset™ Threaded Insert Chemical Injection
 Threaded Insert M12 (062760)
 ChemSet™ Reo 502™ Plus (RE0502P600)
 Maximum fixed thickness to be 8 mm.
 To be installed in accordance with Ramset™ Installation Instructions.

Introduction

[Back to index](#)

CHEMICAL ANCHORING - REINFORCING BAR ANCHORING



Chemical Anchoring Reinforcing Bar Anchorage

The following section applies to reinforcing bar in anchorage applications. For structural post-installed reinforcing bar designs intended to comply with AS3600, please refer to the section titled Chemical Anchoring Reinforcing Bar to AS3600 & AS5216.

- Reinforcing bar complying with the requirements of grade 500 according to current revision of AS/NZS 4671.
- Reidbar™ Continuously threaded reinforcing bar.
- Design requirements for shallow anchorage of reinforcement relating to Safety Critical Applications and AS5216 or EN1992-4.

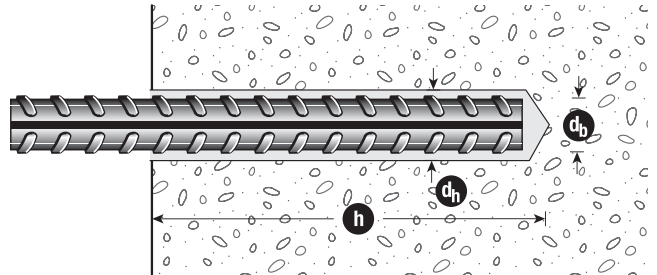

ChemSet™ Reo 502™ PLUS

CHEMICAL INJECTION - NON-CRACKED & CRACKED CONCRETE

Back to index

AVAILABLE IN AUSTRALIA ONLY

(New Zealand refer to EPCON™ C6 PLUS range)

GENERAL INFORMATION

Performance Related	Installation Related

Product

ChemSet™ Reo 502™ PLUS is a heavy duty pure Epoxy for anchoring threaded studs and reinforcing bar into cracked and uncracked concrete.



Compliance

European Technical Assessment (option 1) - ETA-18/0675

Design according to:

- AS5216 (formerly TS101)
- EN1992-4 (formerly ETAG001 Annex C, E & TR045)
- Use enclosed data for simplified calculation method

Use Ramset™ iExpert Anchor Software for optimised calculation or where a greater range of anchor layout detail is needed.

Benefits, Advantages and Features

- European Technical Approval 001 Part 5-option 1
- 100 year working Life

Greater productivity:

- Anchors in dry, damp, wet or flooded holes
- Easy dispensing even in cold weather

Greater security:

- Strong bond
- Rated for sustained loading

Versatile:

- Anchors in carbide drilled and diamond drilled holes*
- Cold and temperate climates

Greater safety:

- Low odour
- VOC Compliant



Principal Applications

- Threaded Studs
- Starter Bars
- Threaded Inserts
- Over-head installation
- Steel Columns
- Hand Rails
- Road Stitching

Recommended Installation Temperatures

	Minimum	Maximum
Substrate	5°C	40°C
Adhesive	10°C	40°C

Service Temperature Limits

-40°C to 70°C

Setting Times

Temperature of base material	Cartridge Temperature	Gel Time	Curing time in dry and wet concrete
5°C	Minimum 10°C	300 min	24 h
10°C	10°C	150 min	18 h
15°C	15°C	40 min	12 h
20°C	20°C	25 min	8 h
25°C	25°C	18 min	6 h
30°C	30°C	12 min	4 h
40°C	40°C	6 min	2 h

Note: Cartridge temperature minimum +10°C

Note

*Performance of cored & oversized holes was not included in the ETAG test program and therefore is based on testing conducted at Ramset™ Product Engineering Laboratory.

Installation

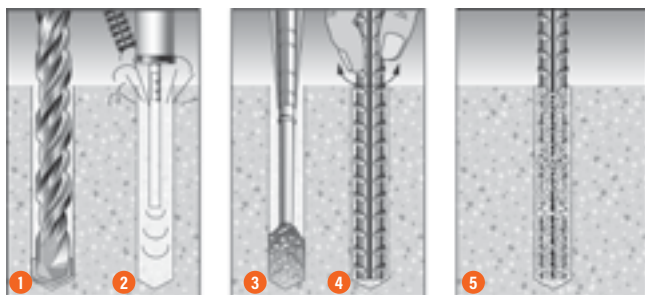

- Drill recommended diameter and depth hole.
- Important:** Use Ramset™ Dustless Drilling System to ensure holes are clean. Alternatively, clean dust and debris from hole with stiff wire or nylon brush and blower in the following sequence: blow x 2, brush x 2, blow x 2, brush x 2, blow x 2.
- Screw mixing nozzle onto cartridge and dispense adhesive until colour is uniform light grey (2-3 trigger pulls). Insert mixing nozzle to bottom of hole. Fill hole to 3/4 the hole depth slowly, ensuring no air pockets form.
- Insert Ramset™ ChemSet™ Anchor Stud/rebar to bottom of hole while turning.
- Allow ChemSet™ Reo 502™ PLUS to cure as per setting times.

ChemSet™ Reo 502™ PLUS

CHEMICAL INJECTION - NON-CRACKED & CRACKED CONCRETE

AVAILABLE IN AUSTRALIA ONLY

Chemical Anchoring - Reinforcing Bar Anchorage

Installation and performance details: ChemSet™ Reo502™ PLUS and Reinforcing Bar

Anchor Size, d_b (mm)	Drilled Hole diam., d_h (mm)	Anchor Effective Depth, h (mm)	Optimum dimensions*			Reduced Characteristic Capacity #				
			Edge* distance, e_c (mm)	Anchor spacing, a_c (mm)	Concrete substrate thickness, b_m (mm)	Gr 500 Rebar - Steel		Non-Cracked Concrete		
						Tension, ϕN_{us} (kN)***	Shear, ϕV_{us} (kN)	Tension, ϕN_{uc} (kN)**		
								Concrete compressive strength, f'_c		
20 MPa	32 MPa	40 MPa								
10	14	90	135	270	115	31.4	21.4	20.4	21.2	21.8
12	16	110	165	330	140	45.2	30.8	29.9	31.1	32.0
16	20	125	187	375	160	80.4	54.8	38.2	43.6	44.8
20	25	150	225	450	190	125.6	85.7	50.2	63.5	67.2
		170	255	510	215			60.5	74.1	76.2
24	32	180	270	540	215	180.8	123.3	66.0	83.5	92.7
		210	315	630	275			83.1	105.2	116.8
32	40	240	360	720	320	321.6	219.3	101.5	111.5	114.7
		300	450	900	380			134.0	139.4	143.4

* Note: For shear loads acting towards an edge or where these optimum dimensions are not achievable, please use the simplified strength limit state design process to verify capacity.

**Note: Reduced characteristic ultimate concrete tensile capacity = ϕN_{uc} where $\phi = 0.56$ and N_{uc} = Characteristic ultimate concrete tensile capacity.

For conversion to Working Load Limit MULTIPLY $\phi N_{uc} \times 0.6$

***Note: Reduced characteristic ultimate steel tensile capacity = ϕN_{us} where $\phi = 0.8$ and N_{us} = Characteristic ultimate steel tensile capacity .

For conversion to Working Load Limit MULTIPLY $\phi N_{us} \times 0.56$

#Note: Design Tensile Capacity ϕN_{us} = minimum of ϕN_{uc} and ϕN_{us}

For Cracked Concrete performance, please use the simplified strength limit state design process to verify capacity.

Data is based on a Service temperature limit of -40°C to +70°C

All data relevant for Dry, Wet and Flooded Holes

For optimised performance data, please use Ramset iExpert Anchoring Software.

DESCRIPTION AND PART NUMBERS

Description	Cartridge Size	Part No.
ChemSet Reo 502 PLUS	600ml	RE0502P600

Typical Engineering Properties of Grade 500 Reinforcing Bar

Rebar Size	10	12	16	20	24	32
Drilled Hole Dia, d_h (mm)	14	16	20	25	32	40
Stress Area, A_s (mm ²)	78.5	113	201	314	491	804
Yield Stress, f_{sy} (MPa)	500	500	500	500	500	500
Tensile Steel Yield Capacity, N_{sy} (kN)	39.3	56.5	100.5	157.0	226.0	402.0

For further information refer to reinforcing bar manufacturer's published information and current revision of AS/NZS 4671

ChemSet™ Reo 502™ PLUS

CHEMICAL INJECTION - NON-CRACKED & CRACKED CONCRETE

AVAILABLE IN AUSTRALIA ONLY

Chemical Anchoring - Reinforcing Bar Anchorage

STEP 1

Select anchor to be evaluated

Table 1a Indicative combined loading - interaction diagram

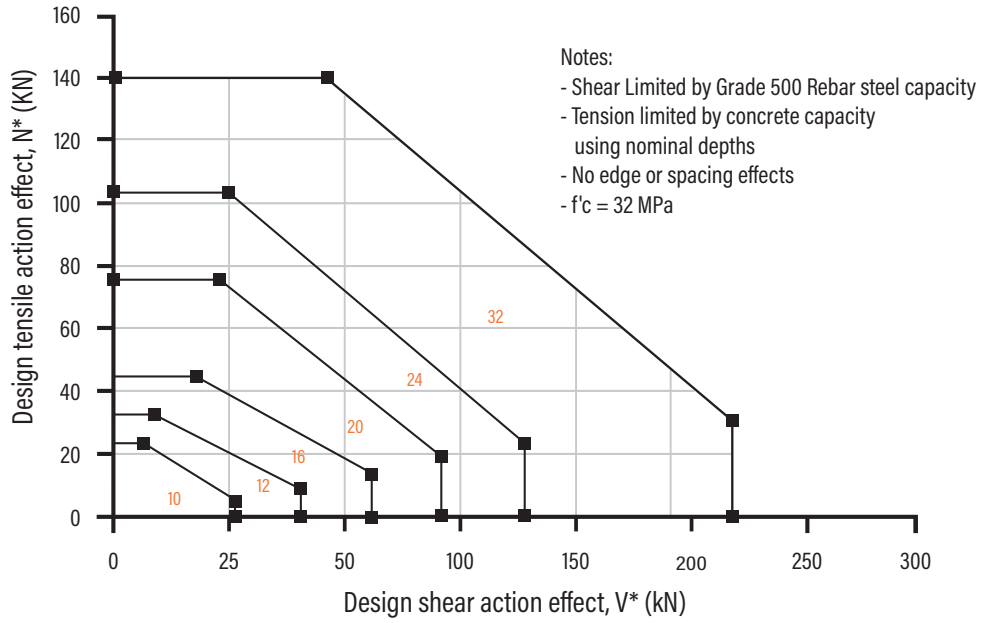

Table 1b Absolute minimum edge distance and anchor spacing values, e_m and a_m (mm)

Rebar size, db	10	12	16	20	24	32
e _m , a _m	40	40	40	50	50	70

Step 1c Calculate anchor effective depth, h (mm)

Refer to nominal recommended effective depths, h, listed in installation and performance details table on previous page.

Effective depth, h (mm)

Preferred $h = h_n$ otherwise,

$h = L_e - t$

t = total thickness of material(s) being fastened.

Substrate thickness b _m (mm)			
Anchor Stud Size (mm)			
10	12	16	20
h + 30mm ≥ 100mm		h + (2 x d _n)	

Checkpoint 1

Anchor size determined, absolute minima compliance achieved, effective depth (h) calculated.

ChemSet™ Reo 502™ PLUS

STRENGTH LIMIT STATE DESIGN

AVAILABLE IN AUSTRALIA ONLY

Chemical Anchoring - Reinforcing Bar Anchorage

STEP 2 Verify concrete tensile capacity - per anchor

Table 2a Reduced characteristic ultimate concrete tensile capacity, ϕN_{uc} (kN), $\phi_c = 1/1.8 = 0.56$, $f'_c = 32$ MPa

Rebar Size, d_b	Combined pull-out and concrete cone resistance - ϕN_{ucp}						Concrete Cone Resistance - ϕN_{ucc}
	10	12	16	20	24	32	
Drilled Hole Dia, d_h (mm)	14	16	20	25	32	40	
Effective Depth, h (mm)							
70	16.5						20.2
80	18.9						24.7
90	21.2	25.5					29.5
100	23.6	28.3					34.6
110	26.0	31.1					39.9
120	28.3	34.0	41.8				45.4
125	29.5	35.4	43.6				48.3
140	33.0	39.6	48.8				57.3
150	35.4	42.5	52.3	65.3			63.5
160	37.8	45.3	55.8	69.7			70.0
170	40.1	48.1	59.2	74.1			76.6
180	42.5	51.0	62.7	78.4	94.1		83.5
190	44.8	53.8	66.2	82.8	99.3		90.5
200	47.2	56.6	69.7	87.1	104.6		97.8
210		59.5	73.2	91.5	109.8		105.2
240		68.0	83.6	104.6	125.5	111.5	128.5
270			94.1	117.6	141.1	125.5	153.4
280			97.6	122.0	146.4	130.1	162.0
300			104.6	130.7	156.8	139.4	179.6
320			111.5	139.4	167.3	148.7	197.9
350				152.5	183.0	162.6	226.4
400				174.3	209.1	185.9	276.6
450					235.2	209.1	330.0
500					261.4	232.3	386.5
560						260.2	458.1
640						297.4	559.7

For optimised performance data, please use Ramset iExpert Anchoring Software.

Table 2a-2 Cracked Concrete effect, tension, X_{ncr}

Rebar Size, d_b	Cracked Concrete Effect - X_{ncr}						X_{ncr} where $\phi N_{uc} = \phi N_{ucc}$ (from Table 2a)
	10	12	16	20	24	32	
f'_c (MPa)							
20 to 50	0.85	0.77	0.83	0.83	0.71	0.81	0.70

Bold values are at Chemset Anchor Stud nominal Depths

For Sustained Loads MULTIPLY ϕN_{uc} x 0.6 (100 years) or ϕN_{uc} x 0.72 (50 years)

All data relevant for Dry, Wet and Flooded Holes

For Non-cracked concrete $X_{ncr} = 1.0$

Calculate ϕN_{uc} for both ϕN_{ucp} and ϕN_{ucc} then choose the minimum - Refer to Checkpoint 2

Table 2b-1 Concrete service temperature limits effect, tension, X_{ns}

Rebar Size, d_b	Service temperature limits effect, tension, X_{ns}						X_{ns} where $\phi N_{uc} = \phi N_{ucc}$ (from Table 2a)
	10	12	16	20	24	32	
Service temperature (°C)							
-40°C to +70°C							1.00

Table 2b-2 Concrete compressive strength effect, tension, X_{nc}

Rebar Size, d_b	Cracked & Non-Cracked Concrete - X_{nc}						X_{nc} where $\phi N_{uc} = \phi N_{ucc}$ (from Table 2a)
	10	12	16	20	24	32	
f'_c (MPa)							
20	0.96	0.96	0.96	0.96	0.96	0.96	0.79
25	0.98	0.98	0.98	0.98	0.98	0.98	0.88
32	1.00	1.00	1.00	1.00	1.00	1.00	1.00
40	1.03	1.03	1.03	1.03	1.03	1.03	1.12
50	1.05	1.05	1.05	1.05	1.05	1.05	1.25

ChemSet™ Reo 502™ PLUS

STRENGTH LIMIT STATE DESIGN

AVAILABLE IN AUSTRALIA ONLY

Chemical Anchoring - Reinforcing Bar Anchorage

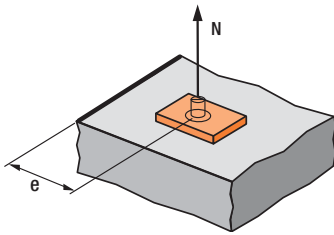

$$X_{ne} = 0.25 + 0.5*(e/h)$$

Where $e_m \leq e \leq e_c$

$$e_c = 1.5*h$$

Note: Tabled values are based on the nominal effective depth, h shown in the installation details. For other values of X_{ne} , please use equation shown above.

Table 2c - Concrete Edge distance effect, tension, X_{ne}

Anchor size, d_b	10	12	16	20	24	32
Edge distance, e (mm)						
40	0.47	0.43	0.41			
45	0.50	0.45	0.43			
50	0.53	0.48	0.45	0.40	0.36	
55	0.56	0.50	0.47	0.41	0.38	
65	0.61	0.55	0.51	0.44	0.40	
70	0.64	0.57	0.53	0.46	0.42	0.36
80	0.69	0.61	0.57	0.49	0.44	0.38
100	0.81	0.70	0.65	0.54	0.49	0.41
115	0.89	0.77	0.71	0.59	0.52	0.44
135	1	0.86	0.79	0.65	0.57	0.47
165		1	0.91	0.74	0.64	0.52
187			1	0.80	0.70	0.56
255				1	0.86	0.67
315					1	0.77
450						1

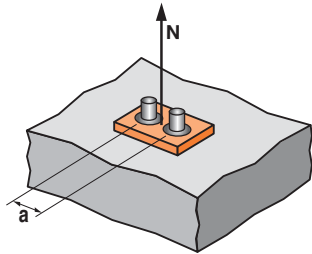

$$X_{na} = 0.5 + a/(6*h)$$

Where $a_m \leq a \leq a_c$

$$a_c = 3*h$$

Note: Tabled values are based on the nominal effective depth, h shown in the installation details. For other values X_{na} , please use equation shown above.

Table 2d - Concrete anchor spacing effect, tension, X_{na}

Anchor size, d_b	10	12	16	20	24	32
Anchor spacing, a (mm)						
40	0.57	0.56	0.55			
45	0.58	0.57	0.56			
50	0.59	0.58	0.57	0.55	0.53	
55	0.60	0.58	0.57	0.55	0.54	
70	0.62	0.60	0.59	0.56	0.55	0.53
85	0.66	0.63	0.61	0.58	0.57	0.54
100	0.69	0.65	0.63	0.60	0.58	0.55
125	0.73	0.69	0.67	0.62	0.60	0.56
150	0.78	0.73	0.70	0.65	0.62	0.58
200	0.87	0.80	0.77	0.70	0.66	0.61
270	1	0.91	0.86	0.76	0.71	0.65
330		1	0.94	0.82	0.76	0.68
375			1	0.87	0.80	0.70
510				1	0.90	0.78
630					1	0.85
900						1

Checkpoint 2

Design reduced ultimate concrete tensile capacity, ϕN_{urc}

$$\phi N_{urc} = \text{minimum of } \phi N_{ucp} * X_{ncr} * X_{ns} * X_{nc} * X_{ne} * X_{na} \text{ and } \phi N_{ucc} * X_{ncr} * X_{ns} * X_{nc} * X_{ne} * X_{na}$$

STEP 3

Verify anchor tensile capacity - per anchor

Table 3a Reduced characteristic ultimate steel tensile capacity, ϕN_{us} (kN), where $\phi = 0.8$

Anchor size, d_b	10	12	16	20	24	32
Gr 500 Rebar	31.4	45.2	80.4	125.6	180.8	321.6

Checkpoint 3

Design reduced ultimate tensile capacity, ϕN_{ur}

$$\phi N_{ur} = \text{minimum of } \phi N_{urc} \text{ and } \phi N_{us}$$

Check $N^*/\phi N_{ur} \leq 1.0$,

if not satisfied return to step 1

ChemSet™ Reo 502™ PLUS

STRENGTH LIMIT STATE DESIGN

AVAILABLE IN AUSTRALIA ONLY

Chemical Anchoring - Reinforcing Bar Anchorage

STEP 4

Step 4 - Verify Concrete shear capacity - per anchor

Table 4a-1 Reduced characteristic ultimate concrete edge shear capacity, ϕV_{uc} (kN), $\phi = 1/1.5 = 0.67$, $f'_c = 32$ MPa

Rebar size, d_b	10	12	16	20	24	32
Effective depth, h (mm)	70-200	90-240	120-320	150-400	180-500	240-640
Edge distance, e						
40	4.3	4.7	5.5			
50				8.2	9.2	
70						16.1

For optimised performance data, please use Ramset iExpert Anchoring Software.

Table 4a-2 Cracked Concrete effect, shear, X_{vcr}

Anchor size, d_b	10	12	16	20	24	32
X_{vcr}	0.70					

For Non-cracked concrete $X_{vcr} = 1.0$

Table 4b - Concrete compressive strength effect, shear, X_{vc}

f'_c (MPa)	20	25	32	40	50
X_{vc}	0.79	0.86	1	1.11	1.22

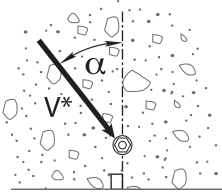

Load direction effect, conc. edge shear, X_{vd}

Table 4c - Concrete load direction effect, concrete edge shear, X_{vd}

Angle, α°	0-55	60	70	80	90-180
X_{vd}	1	1.1	1.2	1.5	2

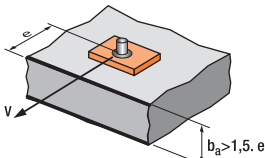

$$X_{ve} = e/e_m * \sqrt{e/e_m}$$

Table 4d - Concrete anchor spacing and edge distance effect, concrete edge shear, X_{ve}

For single anchor fastening X_{ve}

e/e_m	1.0	1.2	1.4	1.6	1.8	2.0	2.2	2.4	2.6	2.8	3.0	3.2
X_{ve}	1.00	1.31	1.66	2.02	2.41	2.83	3.26	3.72	4.19	4.69	5.20	5.72

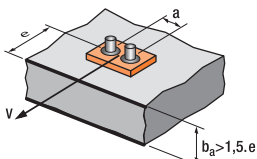

$$X_{ve} = \frac{3 * e + a}{6 * e_m} * \sqrt{e/e_m}$$

For 2 anchors fastening X_{ve}

e/e_m	1.0	1.2	1.4	1.6	1.8	2.0	2.2	2.4	2.6	2.8	3.0	3.2
a/e_m												
1.0	0.67	0.84	1.03	1.22	1.43	1.65	1.88	2.12	2.36	2.62	2.89	3.16
1.5	0.75	0.93	1.12	1.33	1.54	1.77	2.00	2.25	2.50	2.76	3.03	3.31
2.0	0.83	1.02	1.22	1.43	1.65	1.89	2.12	2.38	2.63	2.90	3.18	3.46
2.5	0.92	1.11	1.32	1.54	1.77	2.00	2.25	2.50	2.77	3.04	3.32	3.61
3.0	1.00	1.20	1.42	1.64	1.88	2.12	2.37	2.63	2.90	3.18	3.46	3.76
3.5		1.30	1.52	1.75	1.99	2.24	2.50	2.76	3.04	3.32	3.61	3.91
4.0			1.62	1.86	2.10	2.36	2.62	2.89	3.17	3.46	3.75	4.05
4.5				1.96	2.21	2.47	2.74	3.02	3.31	3.60	3.90	4.20
5.0					2.33	2.59	2.87	3.15	3.44	3.74	4.04	4.35
5.5						2.71	2.99	3.28	3.71	4.02	4.33	4.65
6.0						2.83	3.11	3.41	3.71	4.02	4.33	4.65

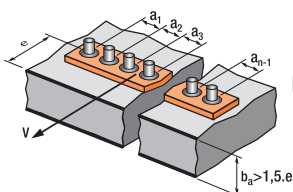

For 3 anchors fastening and more

$$X_{ve} = \frac{3 * e + a_1 + a_2 + a_3 + \dots + a_{n-1}}{3 * n * e_m} * \sqrt{e/e_m}$$

ChemSet™ Reo 502™ PLUS

STRENGTH LIMIT STATE DESIGN

AVAILABLE IN AUSTRALIA ONLY

Chemical Anchoring - Reinforcing Bar Anchorage

Table 4e Reduced characteristic ultimate concrete pryout capacity, ϕV_{ucp} (kN), $\phi = 1/1.5 = 0.67$, $f'_c = 32$ MPa

Rebar size, d_b	10	12	16	20	24	32
Effective depth, h (mm)	90	110	125	170	210	300
-40 °C to +70 °C	40.8	59.9	83.8	142.4	211.1	268.1

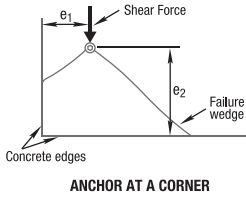

Table 4f Anchor at a corner effect, concrete edge shear, X_{VS}

Note: For $e_1/e_2 > 1.25$, $X_{VS} = 1.0$

Edge distance, e_2 (mm)	25	30	35	50	60	75	125	200	300	400	600	900
Edge distance, e_1 (mm)												
25	0.86	0.77	0.70	0.58	0.53	0.49	0.41	0.37	0.35	0.34	0.32	0.32
30	0.97	0.86	0.78	0.64	0.58	0.52	0.43	0.38	0.36	0.34	0.33	0.32
35	1.00	0.95	0.86	0.69	0.63	0.56	0.46	0.40	0.37	0.35	0.33	0.32
50	1.00	1.00	1.00	0.86	0.77	0.67	0.52	0.44	0.39	0.37	0.35	0.33
60	1.00	1.00	1.00	0.97	0.86	0.75	0.57	0.47	0.41	0.38	0.36	0.34
75	1.00	1.00	1.00	1.00	1.00	0.86	0.64	0.51	0.44	0.41	0.37	0.35
125	1.00	1.00	1.00	1.00	1.00	1.00	0.86	0.65	0.53	0.48	0.42	0.38
200	1.00	1.00	1.00	1.00	1.00	1.00	1.00	0.86	0.67	0.58	0.49	0.42
300	1.00	1.00	1.00	1.00	1.00	1.00	1.00	1.00	0.86	0.72	0.58	0.49
400	1.00	1.00	1.00	1.00	1.00	1.00	1.00	1.00	1.00	0.86	0.67	0.55
500	1.00	1.00	1.00	1.00	1.00	1.00	1.00	1.00	1.00	1.00	0.77	0.61
600	1.00	1.00	1.00	1.00	1.00	1.00	1.00	1.00	1.00	1.00	0.86	0.67
900	1.00	1.00	1.00	1.00	1.00	1.00	1.00	1.00	1.00	1.00	1.00	0.86

Checkpoint **4a**

Design reduced ultimate concrete edge shear capacity, ϕV_{urc}
 $\phi V_{urc} = \phi V_{uc} * X_{vcr} * X_{vc} * X_{vd} * X_{ve} * X_{vs}$

Checkpoint **4b**

Design reduced ultimate concrete pryout capacity, ϕV_{urcp}
 $\phi V_{urcp} = \phi V_{ucp} * X_{ncr} * X_{nc} * X_{ne} * X_{na}$

STEP **5**

Verify anchor shear capacity - per anchor

Table 5a Reduced characteristic ultimate steel shear capacity, ϕV_{usr} (kN) where $\phi_v = 0.80$

Anchor size, d_b	10	12	16	20	24	32
Gr 500 Rebar	21.4	30.8	54.8	85.7	123.3	219.3

Checkpoint **5**

Design reduced ultimate shear capacity, ϕV_{ur}
 $\phi V_{ur} = \text{minimum of } \phi V_{urc}, \phi V_{urcp}, \phi V_{usr}$
 Check $V^*/\phi V_{ur} \leq 1.0$, if not satisfied return to step 1

ChemSet™ Reo 502™ PLUS

STRENGTH LIMIT STATE DESIGN

AVAILABLE IN AUSTRALIA ONLY

Chemical Anchoring - Reinforcing Bar Anchorage

STEP 6 Combined loading and specification

Checkpoint 6

Check
 $N^*/\phi N_{ur} + V^*/\phi V_{ur} \leq 1.2,$
 if not satisfied return to step 1

Specify - Reinforcing Bar Anchorage

Ramset™ ChemSet™ Reo 502™ PLUS with (Anchor Size) grade 500 Rebar.
 Drilled hole depth to be (h) mm.

Example

Ramset™ ChemSet™ Reo 502™ PLUS with 16mm grade 500 Rebar
 Drilled hole depth to be 125 mm.
 To be installed in accordance with Ramset™ Installation Instructions.

Ramset™ iExpert Anchor Software for optimised calculation or where a greater range of anchor layout detail is needed.

EPCON™ C8 Xtrem™

CHEMICAL INJECTION - NON-CRACKED & CRACKED CONCRETE

[Back to index](#)

GENERAL INFORMATION

Performance Related	Installation Related

Product

EPCON™ C8 Xtrem™ is a High Performance Pure Epoxy Anchoring adhesive for use in Cracked and Non-Cracked concrete. For structures subject to external exposure, permanently damp or aggressive conditions.



Compliance

European Technical Assessment (option 1) - ETA-10/0309

Design according to:

- AS5216 (formerly TS101)
- EN1992-4 (formerly ETAG001 Annex C, E & TR045)
- Use enclosed data for simplified calculation method

Use Ramset™ iExpert Anchor Software for optimised calculation or where a greater range of anchor layout detail is needed.



Benefits, Advantages and Features

- 50 year working life

Greater productivity:

- Anchors in dry, damp, wet or flooded holes
- No weather delays
- Fast, easy dispensing with high flow mixer

Greater security:

- Highest performance in cracked concrete
- Rated for sustained loading

Versatile

- Anchors all stud & bar diameters in all directions
- Oversized holes*
- Anchors in carbide drilled and diamond cored holes*
- For tropical and Cold weather conditions

Greater safety:

- Low odour

Fire Rated : Refer Fire rated anchoring section

Principal Applications

- Anchoring into cracked & non cracked concrete
- Road barrier hold down bolts
- Bridge refurbishment
- Road & Rail tunnel construction
- Reinforcing bar from 10 to 32mm
- Starter Bars
- Threaded studs from M8 to M30
- Threaded Stud material: Zn, A4 316, HCR steels
- Threaded Stud material: 5.8, 8.8, 10.9 grade

Recommended Installation Temperatures

	Minimum	Maximum
Substrate	5°C	40°C
Adhesive	5°C	40°C

Load should not be applied to anchor until the chemical has sufficiently cured as specified.

Service Temperature Limits

-40°C to 80°C

Setting Times EPCON™ C8 Xtrem™

Temperature of base material	Gel Time	Curing time in dry concrete	Curing time in wet concrete
5°C - 9°C	20 min	30 h	60 h
10°C - 19°C	14 min	23 h	46 h
20°C - 24°C	11 min	16 h	32 h
25°C - 29°C	8 min	12 h	24 h
30°C - 39°C	5 min	8 h	16 h
40°C	5 min	6 h	12 h

Note

*Performance of cored & oversized holes was not included in the ETAG test program and therefore is based on testing conducted at Ramset™ Product Engineering Laboratory.

Installation

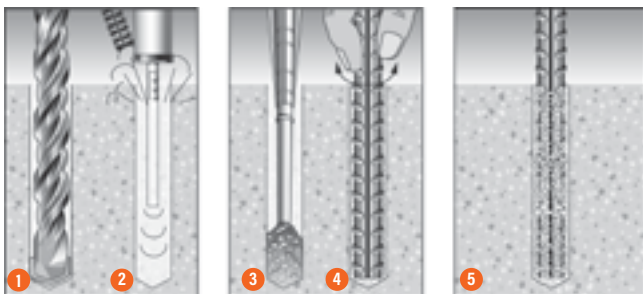

- Drill or core hole to specified diameter and depth
- Important:** Use Ramset™ Dustless Drilling System to ensure holes are clean. Alternatively, clean dust and debris from hole with stiff wire or nylon brush and blower in the following sequence: blow x 2, brush x 2, blow x 2.
- Screw mixing nozzle onto cartridge and dispense 2-3 trigger pulls of adhesive to waste until colour is grey with no streaks
- Insert tip of nozzle to bottom of hole and dispense adhesive
- Fill hole to about 2/3 full
- Insert reinforcing bar with rotating motion to release trapped air
- Wait until adhesive has fully cured before loading (see Working Time / Loading Time chart)
- Clean up with Acetone

EPCON™ C8 Xtrem™

CHEMICAL INJECTION - NON-CRACKED & CRACKED CONCRETE

Chemical Anchoring - Reinforcing Bar Anchorage

Installation and performance details: EPCON™ C8 Xtrem™ and Reinforcing Bar

Anchor Size, d _b (mm)	Drilled Hole diam., d _h (mm)	Anchor Effective Depth, h (mm)	Optimum dimensions*			Reduced Characteristic Capacity #				
			Edge* distance, e _c (mm)	Anchor spacing, a _c (mm)	Concrete substrate thickness, b _m (mm)	Gr 500 Rebar - Steel		Non-Cracked Concrete		
						Tension, φN _{us} (kN)***	Shear, φV _{us} (kN)	Tension, φN _{uc} (kN)**		
								Concrete compressive strength, f' _c		
20 MPa	32 MPa	40 MPa								
10	12	90	135	270	115	31.4	21.4	22.0	23.3	24.6
12	15	110	165	330	140	45.2	30.8	32.0	34.2	36.1
16	20	125	187.5	375	160	80.4	54.8	38.2	48.3	53.6
		150	225	450	190	125.6	85.7	50.2	63.5	70.5
20	25	170	255	510	215			180.8	123.3	60.5
		180	270	540	215	66.0	83.5			92.7
24	30	210	315	630	275	196.4	133.9	83.1	105.2	116.8
		180	270	540	215			66.0	83.5	92.7
25	30	210	315	630	275	246.4	168.0	83.1	105.2	116.8
		210	315	630	275			83.1	105.2	116.8
28	35	270	405	810	340	321.6	219.3	121.2	153.4	170.2
		210	315	630	280			83.1	105.2	116.8
32	40	240	360	720	320	101.5	128.5	101.5	128.5	142.7
		300	450	900	380			141.9	179.6	199.4

* Note: For shear loads acting towards an edge or where these optimum dimensions are not achievable, please use the simplified strength limit state design process to verify capacity.

**Note: Reduced characteristic ultimate concrete tensile capacity = φN_{uc} where φ = 0.56 and N_{uc} = Characteristic ultimate concrete tensile capacity.

For conversion to Working Load Limit MULTIPLY φN_{uc} x 0.6

***Note: Reduced characteristic ultimate steel tensile capacity = φN_{us} where φ = 0.8 and N_{us} = Characteristic ultimate steel tensile capacity.

For conversion to Working Load Limit MULTIPLY φN_{us} x 0.56

#Note: Design Tensile Capacity φN_d = minimum of φN_{uc} and φN_{us}

For Cracked Concrete performance, please use the simplified strength limit state design process to verify capacity.

Data is based on a Service temperature limit of -40°C to +40°C

FLOODED HOLES: Multiply φN_{uc} x 0.65

For optimised performance data, please use Ramset iExpert Anchoring Software.

DESCRIPTION AND PART NUMBERS

Description	Cartridge Size	Part No.
EPCON™ C8 Xtrem™	450ml	C8-450

Drilled hole depth, h₁ (mm)
 h₁ = h
 h = Effective depth

Typical Engineering Properties of Grade 500 Reinforcing Bar

Rebar Size	10	12	16	20	24	25	28	32
Drilled Hole Dia, d _h (mm)	12	15	20	25	30	30	35	40
Stress Area, A _s (mm ²)	78.5	113	201	314	452	491	616	804
Yield Stress, f _{sy} (MPa)	500	500	500	500	500	500	500	500
Tensile Steel Yield Capacity, N _{sy} (kN)	39.3	56.5	100.5	157.0	226.0	245.5	308.0	402.0

For further information refer to reinforcing bar manufacturer's published information and current revision of AS/NZS 4671

EPCON™ C8 Xtrem™

STRENGTH LIMIT STATE DESIGN

STEP 1 Select anchor to be evaluated

Table 1a - Indicative combined loading - interaction diagram

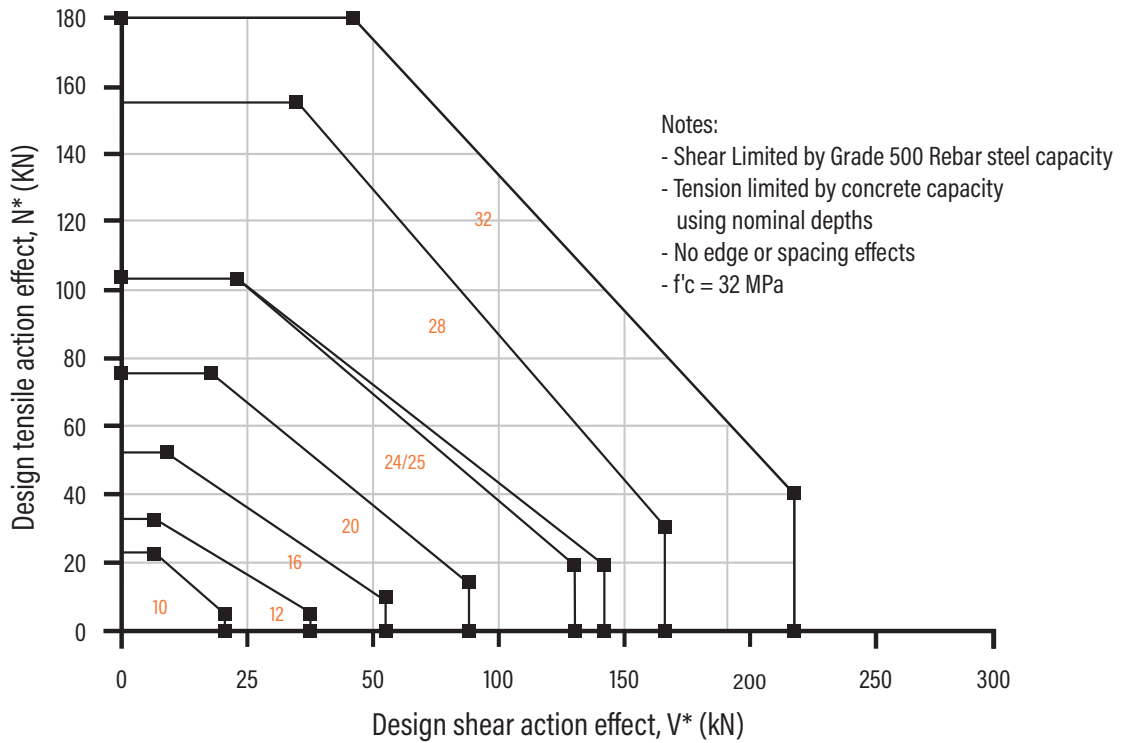

Table 1b - Absolute minimum edge distance and anchor spacing values, e_m and a_m (mm) for cracked concrete

Rebar size, d_b	10	12	16	20	24	25	28	32
Min. Anchor spacing - a_m	50	60	80	100	125	125	140	160
Min. Edge Distance - e_m	50	60	80	100	125	125	140	160

Step 1c Calculate anchor effective depth, h (mm)

Refer to nominal recommended effective depths, h , listed in installation and performance details table on previous page.

Effective depth, h (mm)

Preferred $h = h_n$ otherwise,

$h = L_e - t$

t = total thickness of material(s) being fastened.

Substrate thickness b_m (mm)		
Rebar Size (mm)		
10	12	16 to 32
$h + 30\text{mm} \geq 100\text{mm}$		$h + (2 \times d_b)$

Checkpoint 1 Anchor size determined, absolute minima compliance achieved, effective depth (h) calculated.

EPCON™ C8 Xtrem™

STRENGTH LIMIT STATE DESIGN

Chemical Anchoring - Reinforcing Bar Anchorage

STEP 2 Verify concrete tensile capacity - per anchor

Table 2a Reduced characteristic ultimate concrete tensile capacity, ϕN_{uc} (kN), $\phi_c = 1/1.8 = 0.56$, $f'_c = 32$ MPa

Rebar Size, d_b	Combined pull-out and concrete cone resistance - ϕN_{ucp}								Concrete Cone Resistance - ϕN_{ucc}
	10	12	16	20	24	25	28	32	
Drilled Hole Dia, d_n (mm)	12	15	20	25	30	30	35	40	
Effective Depth, h (mm)									
70	18.1								20.2
80	20.7								24.7
90	23.3	28.2							29.5
100	25.9	31.4							34.6
110	28.5	34.5							39.9
120	31.1	37.6	51.1						45.4
125	32.4	39.2	53.3						48.3
140	36.3	43.9	59.7						57.3
150	38.9	47.1	63.9	75.6					63.5
160	41.4	50.2	68.2	80.6					70.0
170	44.0	53.3	72.4	85.6					76.6
180	46.6	56.5	76.7	90.7	111.7	116.4			83.5
190	49.2	59.6	81.0	95.7	117.9	122.9			90.5
200	51.8	62.7	85.2	100.7	124.2	129.3			97.8
210		65.9	89.5	105.8	130.4	135.8	153.4		105.2
240		75.3	102.3	120.9	149.0	155.2	175.3	189.8	128.5
270			115.1	136.0	167.6	174.6	197.3	213.5	153.4
280			119.3	141.0	173.8	181.1	204.6	221.4	162.0
300			127.8	151.1	186.2	194.0	219.2	237.3	179.6
320			136.4	161.2	198.6	206.9	233.8	253.1	197.9
350				176.3	217.3	226.3	255.7	276.8	226.4
400				201.5	248.3	258.7	292.2	316.3	276.6
450					279.4	291.0	328.8	355.9	330.0
500					310.4	323.3	365.3	395.4	386.5
560							409.1	442.9	458.1
640								506.1	559.7

For optimised performance data, please use Ramset iExpert Anchoring Software.

Table 2a-2 Cracked Concrete effect, tension, X_{ncr}

Rebar Size, d_b	Cracked Concrete Effect - X_{ncr}								X_{ncr}
	where $\phi N_{uc} = \phi N_{ucp}$ (from Table 2a)								
f'_c (MPa)									where $\phi N_{uc} = \phi N_{ucc}$ (from Table 2a)
20 to 50	0.67	0.64	0.60	0.60	0.60	0.60	0.57	0.50	0.70

Bold values are at Chemset Anchor Stud nominal Depths.

For Sustained Loads MULTIPLY ϕN_{uc} x 0.6 FLOODED HOLES: Multiply ϕN_{uc} x 0.65 For Non-cracked concrete $X_{ncr} = 1$.

If Service temperature limit is -40°C to +40°C then Refer to Checkpoint 2	If Service temperature limit is -40°C to +80°C then $\phi N_{uc} = \phi N_{ucp}$
---	--

Table 2b-1 Concrete service temperature limits effect, tension, X_{ns}

Rebar Size, d_b	Service temperature limits effect, tension, X_{ns}								X_{ns}
	where $\phi N_{uc} = \phi N_{ucp}$ (from Table 2a)								
Service temperature (°C)									where $\phi N_{uc} = \phi N_{ucc}$ (from Table 2a)
-40 °C to +40 °C	1.00	1.00	1.00	1.00	1.00	1.00	1.00	1.00	1.00
-40 °C to +80 °C	0.57	0.53	0.52	0.52	0.56	0.56	0.53	0.53	1.00

Table 2b-2 Concrete compressive strength effect, tension, X_{nc}

NON- CRACKED	Non-Cracked Concrete - X_{nc}								X_{nc}
	where $\phi N_{uc} = \phi N_{ucp}$ (from Table 2a)								
Rebar Size, d_b	10	12	16	20	24	25	28	32	where $\phi N_{uc} = \phi N_{ucc}$ (from Table 2a)
f'_c (MPa)									
20	0.94	0.93	0.92	0.90	0.88	0.88	0.87	0.85	0.79
25	0.97	0.96	0.95	0.95	0.93	0.93	0.93	0.92	0.88
32	1.00	1.00	1.00	1.00	1.00	1.00	1.00	1.00	1.00
40	1.06	1.06	1.07	1.09	1.11	1.11	1.12	1.13	1.11
50	1.08	1.09	1.12	1.14	1.18	1.18	1.20	1.22	1.25

CRACKED	Cracked Concrete - X_{nc}								X_{nc}
	where $\phi N_{uc} = \phi N_{ucp}$ (from Table 2a)								
Rebar Size, d_b	10	12	16	20	24	25	28	32	where $\phi N_{uc} = \phi N_{ucc}$ (from Table 2a)
f'_c (MPa)									
20	0.95	0.95	0.94	0.93	0.92	0.92	0.91	0.90	0.79
25	0.97	0.97	0.97	0.96	0.95	0.95	0.95	0.95	0.88
32	1.00	1.00	1.00	1.00	1.00	1.00	1.00	1.00	1.00
40	1.03	1.04	1.05	1.07	1.06	1.06	1.07	1.08	1.11
50	1.05	1.07	1.08	1.09	1.11	1.11	1.12	1.14	1.25

EPCON™ C8 Xtrem™

STRENGTH LIMIT STATE DESIGN

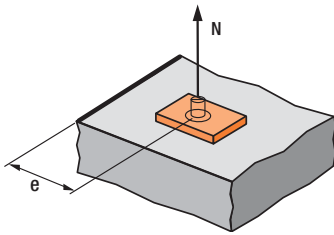

$$X_{ne} = 0.25 + 0.5 \cdot (e/h)$$

Where $e_m \leq e \leq e_c$

$$e_c = 1.5 \cdot h$$

Note: Tabled values are based on the nominal effective depth, h shown in the installation details. For other values of X_{ne} , please use equation shown above.

Table 2c - Concrete Edge distance effect, tension, X_{ne}

Rebar size, d_b	10	12	16	20	24/25	28	32
Edge distance, e (mm)							
50	0.53						
60	0.58	0.52					
80	0.69	0.61	0.57				
90	0.75	0.66	0.61				
100	0.81	0.70	0.65	0.54			
125	0.94	0.82	0.75	0.62	0.55		
140	1.03	0.89	0.81	0.66	0.58	0.51	
165		1.00	0.91	0.74	0.64	0.56	0.53
187			1.00	0.80	0.70	0.60	0.56
255				1.00	0.86	0.72	0.68
315					1.00	0.83	0.78
405						1.00	0.93
450							1.00
315						1	0.81
420							1

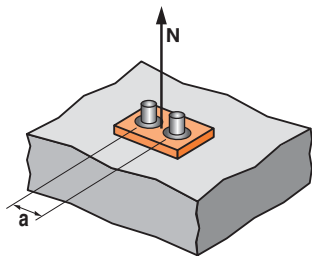

$$X_{na} = 0.5 + a/(6 \cdot h)$$

Where $a_m \leq a \leq a_c$

$$a_c = 3 \cdot h$$

Note: Tabled values are based on the nominal effective depth, h shown in the installation details. For other values X_{na} , please use equation shown above.

Table 2d - Concrete anchor spacing effect, tension, X_{na}

Rebar size, d_b	10	12	16	20	24/25	28	32
Anchor spacing, a (mm)							
50	0.59						
60	0.61	0.59					
80	0.65	0.62	0.61				
100	0.69	0.65	0.63	0.60			
125	0.73	0.69	0.67	0.62	0.60		
140	0.76	0.71	0.69	0.64	0.61	0.59	
160	0.80	0.74	0.71	0.66	0.63	0.60	0.59
200	0.87	0.80	0.77	0.70	0.66	0.62	0.61
270	1.00	0.91	0.86	0.76	0.71	0.67	0.65
330		1.00	0.94	0.82	0.76	0.70	0.68
375			1.00	0.87	0.80	0.73	0.71
510				1.00	0.90	0.81	0.78
630					1.00	0.89	0.85
810						1.00	0.95
900							1.00

Checkpoint 2

Design reduced ultimate concrete tensile capacity, ϕN_{urc}

$$\phi N_{urc} = \phi N_{uc} \cdot X_{ncr} \cdot X_{ns} \cdot X_{nc} \cdot X_{ne} \cdot X_{na}$$

If Service temperature limit is -40°C to +40°C then

$$\phi N_{urc} = \text{minimum of } \phi N_{ucp} \cdot X_{ncr} \cdot X_{ns} \cdot X_{nc} \cdot X_{ne} \cdot X_{na} \text{ and } \phi N_{ucc} \cdot X_{ncr} \cdot X_{ns} \cdot X_{nc} \cdot X_{ne} \cdot X_{na}$$

STEP 3

Verify anchor tensile capacity - per anchor

Table 3a Reduced characteristic ultimate steel tensile capacity, ϕN_{us} (kN), where $\phi = 0.8$

Anchor size, d_b	10	12	16	20	24	25	28	32
Gr 500 Rebar	31.4	45.2	80.4	125.6	180.8	196.4	246.4	321.6

Checkpoint 3

Design reduced ultimate tensile capacity, ϕN_{ur}

$$\phi N_{ur} = \text{minimum of } \phi N_{urc} \text{ and } \phi N_{us}$$

Check $N^*/\phi N_{ur} \leq 1.0$,

if not satisfied return to step 1

EPCON™ C8 Xtrem™

STRENGTH LIMIT STATE DESIGN

STEP 4 Step 4 - Verify Concrete Shear Capacity - per anchor

Table 4a-1 Reduced characteristic ultimate concrete edge shear capacity, ϕV_{uc} (kN), $\phi = 1/1.5 = 0.67$, $f'_c = 32$ MPa

Rebar size, d_b	10	12	16	20	24	25	28	32
Effective depth, h (mm)	70 - 200	90-240	120-320	150-400	180-500	180-500	210-560	240-640
Edge distance, e_m								
50	5.7							
60		7.9						
80			12.9					
100				18.8				
125					26.9	27.1		
140							33.2	
160								41.7

For optimised performance data, please use Ramset iExpert Anchoring Software.

Table 4a-2 Cracked Concrete effect, shear, X_{vcr}

Anchor size, d_b	10	12	16	20	24	25	28	32
X_{vcr}	0.70							

For Non-cracked concrete $X_{vcr} = 1.0$

Table 4b - Concrete compressive strength effect, shear, X_{vc}

f'_c (MPa)	20	25	32	40	50
X_{vc}	0.79	0.86	1.0	1.11	1.22

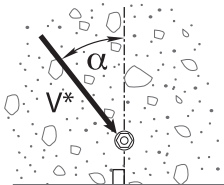

Load direction effect, conc. edge shear, X_{vd}

Table 4c - Concrete load direction effect, concrete edge shear, X_{vd}

Angle, α°	0-55	60	70	80	90-180
X_{vd}	1	1.1	1.2	1.5	2

Table 4d - Concrete anchor spacing and edge distance effect, concrete edge shear, X_{ve}

For single anchor fastening X_{ve}

e/e_m	1.0	1.2	1.4	1.6	1.8	2.0	2.2	2.4	2.6	2.8	3.0	3.2
X_{ve}	1.00	1.31	1.66	2.02	2.41	2.83	3.26	3.72	4.19	4.69	5.20	5.72

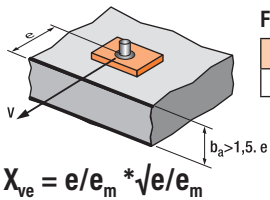

$$X_{ve} = e/e_m * \sqrt{e/e_m}$$

For 2 anchors fastening X_{ve}

e/e_m	1.0	1.2	1.4	1.6	1.8	2.0	2.2	2.4	2.6	2.8	3.0	3.2
a/e_m												
1.0	0.67	0.84	1.03	1.22	1.43	1.65	1.88	2.12	2.36	2.62	2.89	3.16
1.5	0.75	0.93	1.12	1.33	1.54	1.77	2.00	2.25	2.50	2.76	3.03	3.31
2.0	0.83	1.02	1.22	1.43	1.65	1.89	2.12	2.38	2.63	2.90	3.18	3.46
2.5	0.92	1.11	1.32	1.54	1.77	2.00	2.25	2.50	2.77	3.04	3.32	3.61
3.0	1.00	1.20	1.42	1.64	1.88	2.12	2.37	2.63	2.90	3.18	3.46	3.76
3.5		1.30	1.52	1.75	1.99	2.24	2.50	2.76	3.04	3.32	3.61	3.91
4.0			1.62	1.86	2.10	2.36	2.62	2.89	3.17	3.46	3.75	4.05
4.5				1.96	2.21	2.47	2.74	3.02	3.31	3.60	3.90	4.20
5.0					2.33	2.59	2.87	3.15	3.44	3.74	4.04	4.35
5.5						2.71	2.99	3.28	3.71	4.02	4.33	4.65
6.0							2.83	3.11	3.41	3.71	4.02	4.33

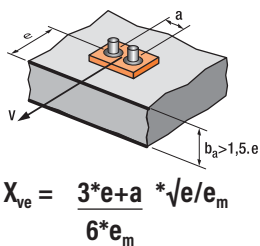

$$X_{ve} = \frac{3 * e + a}{6 * e_m} * \sqrt{e/e_m}$$

For 3 anchors fastening and more

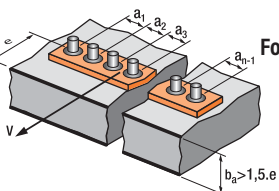

$$X_{ve} = \frac{3 * e + a_1 + a_2 + a_3 + \dots + a_{n-1}}{3 * n * e_m} * \sqrt{e/e_m}$$

EPCON™ C8 Xtrem™

STRENGTH LIMIT STATE DESIGN

Table 4e Reduced characteristic ultimate concrete pryout capacity, ϕV_{ucp} (kN), $\phi = 1/1.5 = 0.67$, $f'_c = 32$ MPa

Rebar size, d_b	10	12	16	20	24	25	28	32
Effective depth, h (mm)	90	110	125	170	210	210	270	300
-40 °C to +40 °C	55.9	79.8	96.6	153.2	210.4	210.4	306.7	359.3
-40 °C to +80 °C	32.0	44.4	68.5	118.6	180.5	188.0	254.9	332.2

Table 4f - Anchor at a corner effect, concrete edge shear, X_{VS}

Note: For $e_1/e_2 > 1.25$, $X_{VS} = 1.0$

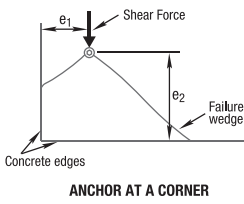

Edge distance, e_2 (mm)	50	60	75	125	200	300	400	600	900
Edge distance, e_1 (mm)									
50	0.86	0.77	0.67	0.52	0.44	0.39	0.37	0.35	0.33
60	0.97	0.86	0.75	0.57	0.47	0.41	0.38	0.36	0.34
75	1.00	1.00	0.86	0.64	0.51	0.44	0.41	0.37	0.35
125	1.00	1.00	1.00	0.86	0.65	0.53	0.48	0.42	0.38
200	1.00	1.00	1.00	1.00	0.86	0.67	0.58	0.49	0.42
300	1.00	1.00	1.00	1.00	1.00	0.86	0.72	0.58	0.49
400	1.00	1.00	1.00	1.00	1.00	1.00	0.86	0.67	0.55
500	1.00	1.00	1.00	1.00	1.00	1.00	1.00	0.77	0.61
600	1.00	1.00	1.00	1.00	1.00	1.00	1.00	0.86	0.67
900	1.00	1.00	1.00	1.00	1.00	1.00	1.00	1.00	0.86

Checkpoint 4a

Design reduced ultimate concrete edge shear capacity, ϕV_{urc}

$$\phi V_{urc} = \phi V_{uc} * X_{vcr} * X_{vc} * X_{vd} * X_{ve} * X_{vs}$$

Checkpoint 4b

Design reduced ultimate concrete pryout capacity, ϕV_{urcp}

$$\phi V_{urcp} = \phi V_{ucp} * X_{ncr} * X_{nc} * X_{ne} * X_{na}$$

STEP 5

Verify anchor shear capacity - per anchor

Table 5a Reduced characteristic ultimate steel shear capacity, ϕV_{usr} (kN) where $\phi v = 0.80$

Anchor size, d_b	10	12	16	20	24	25	28	32
Gr 500 Rebar	21.4	30.8	54.8	85.7	123.3	133.9	168.0	219.3

Checkpoint 5

Design reduced ultimate shear capacity, ϕV_{ur}

$$\phi V_{ur} = \text{minimum of } \phi V_{urc}, \phi V_{urcp}, \phi V_{usr}$$

Check $V^*/\phi V_{ur} \leq 1$,

if not satisfied return to step 1

EPCON™ C8 Xtrem™

STRENGTH LIMIT STATE DESIGN

Chemical Anchoring - Reinforcing Bar Anchorage

STEP 6 Combined loading and specification

Checkpoint 6

Check

$$N^*/\phi N_{ur} + V^*/\phi V_{ur} \leq 1.2,$$
 if not satisfied return to step 1

Specify - Reinforcing Bar Anchorage

Ramset™ EPCON™ C8 Xtrem™ with (Anchor Size) grade 500 Rebar.
 Drilled hole depth to be (h) mm.

Example

Ramset™ EPCON™ C8 Xtrem™ with 16mm grade 500 Rebar
 Drilled hole depth to be 125 mm.
 To be installed in accordance with Ramset Installation Instructions.

Ramset™ iExpert Anchor Software for optimised calculation or where a greater range of anchor layout detail is needed.

EPCON™ C6 PLUS

CHEMICAL INJECTION - NON-CRACKED & CRACKED CONCRETE

Back to index

AVAILABLE IN NEW ZEALAND ONLY

(Australia refer to ChemSet™ Reo502™ PLUS range)

GENERAL INFORMATION

Performance Related



Installation Related



Product

EPCON™ C6 PLUS is a heavy duty pure Epoxy for anchoring threaded studs and reinforcing bar into cracked and uncracked concrete.



Compliance

European Technical Assessment (option 1) - ETA-18/0675

Design according to:

- AS5216 (formerly TS101)
- EN1992-4 (formerly ETAG001 Annex C, E & TR045)
- Use enclosed data for simplified calculation method

Use Ramset™ iExpert Anchor Software for optimised calculation or where a greater range of anchor layout detail is needed.

Benefits, Advantages and Features

- 100 year working Life
- Greater productivity:**
 - Easy dispensing even in cold weather
 - Anchors in dry, damp, wet or flooded holes
- Greater security:**
 - Strong bond
 - Rated for sustained loading
- Versatile:**
 - Anchors in carbide drilled and diamond drilled holes*
 - Cold and temperate climates
- Greater safety:**
 - Low odour
 - VOC Compliant

Principal Applications

- Threaded Studs
- Starter Bars
- Threaded Inserts
- Over-head installation
- Steel Columns
- Hand Rails
- Road Stitching

Recommended Installation Temperatures

	Minimum	Maximum
Substrate	5°C	40°C
Adhesive	10°C	40°C

Service Temperature Limits

-40°C to +70°C

Setting Times

Temperature of base material	Cartridge Temperature	Gel Time	Curing time in dry and wet concrete
5°C	Minimum 10°C	300 min	24 h
10°C	10°C	150 min	18 h
15°C	15°C	40 min	12 h
20°C	20°C	25 min	8 h
25°C	25°C	18 min	6 h
30°C	30°C	12 min	4 h
40°C	40°C	6 min	2 h

Note: Cartridge temperature minimum +10°C

Note

*Performance of cored & oversized holes was not included in the ETAG test program and therefore is based on testing conducted at Ramset™ Product Engineering Laboratory.

Installation

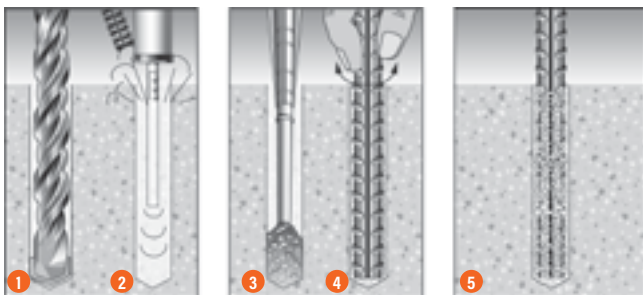

- Drill or core hole to specified diameter and depth
- Important:** Use Ramset™ Dustless Drilling System to ensure holes are clean. Alternatively, clean dust and debris from hole with stiff wire or nylon brush and blower in the following sequence: blow x 2, brush x 2, blow x 2, brush x 2, blow x 2.
- Screw mixing nozzle onto cartridge and dispense 2-3 trigger pulls of adhesive to waste until colour is grey with no streaks
- Insert tip of nozzle to bottom of hole and dispense adhesive
- Fill hole to about 2/3 full
- Insert reinforcing bar with rotating motion to release trapped air
- Wait until adhesive has fully cured before loading (see Working Time / Loading Time chart)
- Clean up with Acetone

EPCON™ C6 PLUS

CHEMICAL INJECTION - NON-CRACKED & CRACKED CONCRETE

AVAILABLE IN NEW ZEALAND ONLY

Installation and performance details: EPCON™ C6 PLUS and Reinforcing Bar

Anchor Size, d_b (mm)	Drilled Hole diam., d_h (mm)	Anchor Effective Depth, h (mm)	Optimum dimensions*			Reduced Characteristic Capacity #				
			Edge* distance, e_c (mm)	Anchor spacing, a_c (mm)	Concrete substrate thickness, b_m (mm)	Gr 500 Rebar - Steel		Non-Cracked Concrete		
						Tension, ϕN_{us} (kN)***	Shear, ϕV_{us} (kN)	Tension, ϕN_{ic} (kN)**		
								Concrete compressive strength, f'_c		
20 MPa	32 MPa	40 MPa								
10	14	90	135	270	115	31.4	21.4	20.4	21.2	21.8
12	16	110	165	330	140	45.2	30.8	29.9	31.1	32.0
16	20	125	187	375	160	80.4	54.8	38.2	43.6	44.8
20	25	150	225	450	190	125.6	85.7	50.2	63.5	67.2
		170	255	510	215			60.5	74.1	76.2
25	32	180	270	540	215	196.4	133.9	66.0	83.5	92.7
		210	315	630	275			83.1	105.2	116.8
32	40	240	360	720	320	321.6	219.3	101.5	111.5	114.7
		300	450	900	380			134.0	139.4	143.4

* Note: For shear loads acting towards an edge or where these optimum dimensions are not achievable, please use the simplified strength limit state design process to verify capacity.

**Note: Reduced characteristic ultimate concrete tensile capacity = ϕN_{ic} where $\phi = 0.56$ and N_{ic} = Characteristic ultimate concrete tensile capacity.

For conversion to Working Load Limit MULTIPLY $\phi N_{ic} \times 0.6$

***Note: Reduced characteristic ultimate steel tensile capacity = ϕN_{us} where $\phi = 0.8$ and N_{us} = Characteristic ultimate steel tensile capacity.

For conversion to Working Load Limit MULTIPLY $\phi N_{us} \times 0.56$

#Note: Design Tensile Capacity ϕN_{ic} = minimum of ϕN_{ic} and ϕN_{us}

For Cracked Concrete performance, please use the simplified strength limit state design process to verify capacity.

Data is based on a Service temperature limit of -40°C to +70°C

All data relevant for Dry, Wet and Flooded Holes

DESCRIPTION AND PART NUMBERS

Description	Cartridge Size	Part No.
Epcon C6 PLUS	600ml	EC6P600

Typical Engineering Properties of Grade 500 Reinforcing Bar

Rebar Size	10	12	16	20	25	32
Drilled Hole Dia, d_h (mm)	14	16	20	25	32	40
Stress Area, A_s (mm ²)	78.5	113	201	314	491	804
Yield Stress, f_{sy} (MPa)	500	500	500	500	500	500
Tensile Steel Yield Capacity, N_{sy} (kN)	39.3	56.5	100.5	157.0	245.5	402.0

For further information refer to reinforcing bar manufacturer's published information and current revision of AS/NZS 4671

EPCON™ C6 PLUS

STRENGTH LIMIT STATE DESIGN

AVAILABLE IN NEW ZEALAND ONLY

Chemical Anchoring - Reinforcing Bar Anchorage

STEP 1 Select anchor to be evaluated

Table 1a Indicative combined loading - interaction diagram

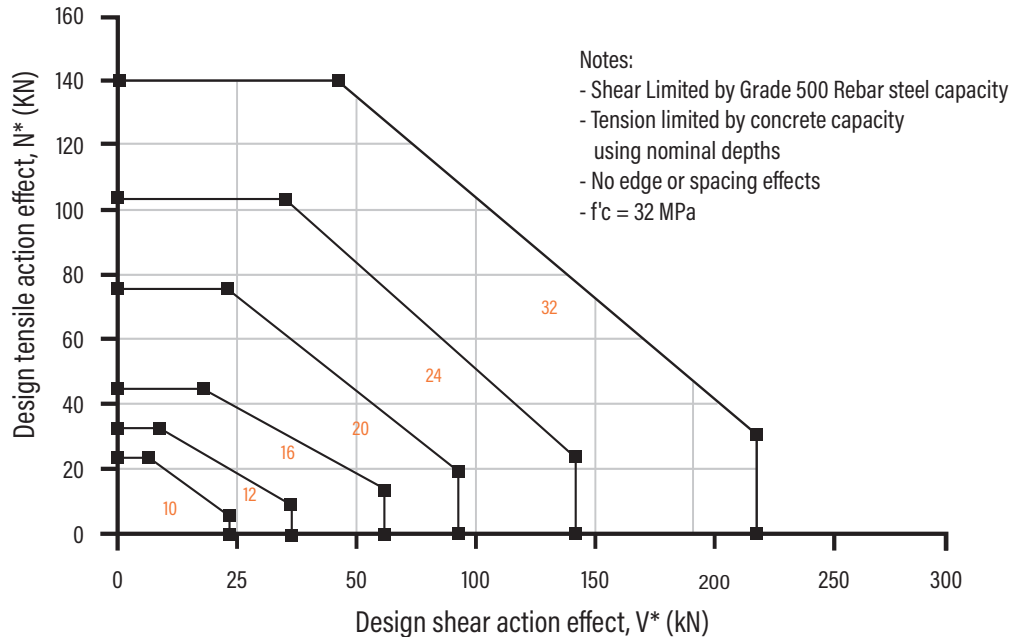

Table 1b Absolute minimum edge distance and anchor spacing values, e_m and a_m (mm)

Anchor size, d _b	10	12	16	20	25	32
Min. Anchor spacing - a _m	40	40	40	50	50	70
Min. Edge Distance - e _m	40	40	40	50	50	70

Step 1c Calculate anchor effective depth, h (mm)

Refer to nominal recommended effective depths, h, listed in installation and performance details table on previous page.

Effective depth, h (mm)

Preferred $h = h_n$ otherwise,

$h = L_e - t$

t = total thickness of material(s) being fastened.

Substrate thickness b _m (mm)		
Anchor Stud Size (mm)		
10	12	16 to 32
$h + 30\text{mm} \geq 100\text{mm}$		$h + (2 \times d_b)$

Checkpoint 1 Anchor size determined, absolute minima compliance achieved, effective depth (h) calculated.

EPCON™ C6 PLUS

STRENGTH LIMIT STATE DESIGN

AVAILABLE IN NEW ZEALAND ONLY

Chemical Anchoring - Reinforcing Bar Anchorage

STEP 2 Verify concrete tensile capacity - per anchor

Table 2a Reduced characteristic ultimate concrete tensile capacity, ϕN_{uc} (kN), $\phi_c = 1/1.8 = 0.56$, $f'_c = 32$ MPa

Rebar Size, d_b	Combined pull-out and concrete cone resistance - ϕN_{ucp}						Concrete Cone Resistance - ϕN_{uc}
	10	12	16	20	25	32	
Drilled Hole Dia, d_h (mm)	14	16	20	25	32	40	
Effective Depth, h (mm)							
70	16.5						20.2
80	18.9						24.7
90	21.2	25.5					29.5
100	23.6	28.3					34.6
110	26.0	31.1					39.9
120	28.3	34.0	41.8				45.4
125	29.5	35.4	43.6				48.3
140	33.0	39.6	48.8				57.3
150	35.4	42.5	52.3	65.3			63.5
160	37.8	45.3	55.8	69.7			70.0
170	40.1	48.1	59.2	74.1			76.6
180	42.5	51.0	62.7	78.4	98.0		83.5
190	44.8	53.8	66.2	82.8	103.5		90.5
200	47.2	56.6	69.7	87.1	108.9		97.8
210		59.5	73.2	91.5	114.4		105.2
240		68.0	83.6	104.6	130.7	111.5	128.5
270			94.1	117.6	147.0	125.5	153.4
280			97.6	122.0	152.5	130.1	162.0
300			104.6	130.7	163.4	139.4	179.6
320			111.5	139.4	174.3	148.7	197.9
350				152.5	190.6	162.6	226.4
400				174.3	217.8	185.9	276.6
450					245.0	209.1	330.0
500					272.3	232.3	386.5
560						260.2	458.1
640						297.4	559.7

For optimised performance data, please use Ramset iExpert Anchoring Software.

Table 2a-2 Cracked Concrete effect, tension, X_{ncr}

Rebar Size, d_b	Cracked Concrete Effect - X_{ncr}						X_{ncr} where $\phi N_{uc} = \phi N_{ucp}$ (from Table 2a)
	10	12	16	20	25	32	
f'_c (MPa)							
20 to 50	0.85	0.77	0.83	0.83	0.71	0.81	0.70

Bold values are at Chemset Anchor Stud nominal Depths

For Sustained Loads MULTIPLY $\phi N_{uc} \times 0.6$ (100 years) or $\phi N_{uc} \times 0.72$ (50 years)

All data relevant for Dry, Wet and Flooded Holes

For Non-cracked concrete $X_{ncr} = 1$

Calculate ϕN_{uc} for both ϕN_{ucp} and ψN_{uc} then choose the minimum - Refer to Checkpoint 2

Table 2b-1 Concrete service temperature limits effect, tension, X_{ns}

Rebar Size, d_b	Service temperature limits effect, tension, X_{ns}						X_{ns} where $\phi N_{uc} = \phi N_{ucp}$ (from Table 2a)
	10	12	16	20	25	32	
Service temperature (°C)							
-40 °C to +70 °C				1.00			1.00

Table 2b-2 Concrete compressive strength effect, tension, X_{nc}

Rebar Size, d_b	Cracked & Non-Cracked Concrete - X_{nc}						X_{nc} where $\phi N_{uc} = \phi N_{ucp}$ (from Table 2a)
	10	12	16	20	25	32	
f'_c (MPa)							
20	0.96	0.96	0.96	0.96	0.96	0.96	0.79
25	0.98	0.98	0.98	0.98	0.98	0.98	0.88
32	1.00	1.00	1.00	1.00	1.00	1.00	1.00
40	1.03	1.03	1.03	1.03	1.03	1.03	1.12
50	1.05	1.05	1.05	1.05	1.05	1.05	1.25

EPCON™ C6 PLUS

STRENGTH LIMIT STATE DESIGN

AVAILABLE IN NEW ZEALAND ONLY

Chemical Anchoring - Reinforcing Bar Anchorage

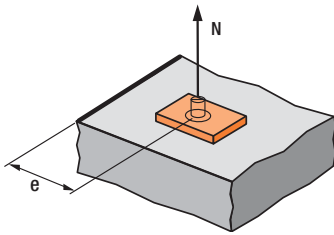

$$X_{ne} = 0.25 + 0.5 \cdot (e/h)$$

Where $e_m \leq e \leq e_c$

$$e_c = 1.5 \cdot h$$

Note: Tabled values are based on the nominal effective depth, h shown in the installation details. For other values of X_{ne} , please use equation shown above.

Table 2c - Concrete Edge distance effect, tension, X_{ne}

Anchor size, d_b	10	12	16	20	25	32
Edge distance, e (mm)						
40	0.47	0.43	0.41			
45	0.50	0.45	0.43			
50	0.53	0.48	0.45	0.40	0.36	
55	0.56	0.50	0.47	0.41	0.38	
65	0.61	0.55	0.51	0.44	0.40	
70	0.64	0.57	0.53	0.46	0.42	0.36
80	0.69	0.61	0.57	0.49	0.44	0.38
100	0.81	0.70	0.65	0.54	0.49	0.41
115	0.89	0.77	0.71	0.59	0.52	0.44
135	1	0.86	0.79	0.65	0.57	0.47
165		1	0.91	0.74	0.64	0.52
187			1	0.80	0.70	0.56
255				1	0.86	0.67
315					1	0.77
450						1

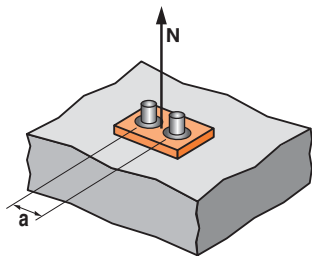

$$X_{na} = 0.5 + a/(6 \cdot h)$$

Where $a_m \leq a \leq a_c$

$$a_c = 3 \cdot h$$

Note: Tabled values are based on the nominal effective depth, h shown in the installation details. For other values X_{na} , please use equation shown above.

Table 2d - Concrete anchor spacing effect, tension, X_{na}

Anchor size, d_b	10	12	16	20	25	32
Anchor spacing, a (mm)						
40	0.57	0.56	0.55			
45	0.58	0.57	0.56			
50	0.59	0.58	0.57	0.55	0.53	
55	0.60	0.58	0.57	0.55	0.54	
70	0.62	0.60	0.59	0.56	0.55	0.53
85	0.66	0.63	0.61	0.58	0.57	0.54
100	0.69	0.65	0.63	0.60	0.58	0.55
125	0.73	0.69	0.67	0.62	0.60	0.56
150	0.78	0.73	0.70	0.65	0.62	0.58
200	0.87	0.80	0.77	0.70	0.66	0.61
270	1	0.91	0.86	0.76	0.71	0.65
330		1	0.94	0.82	0.76	0.68
375			1	0.87	0.80	0.70
510				1	0.90	0.78
630					1	0.85
900						1

Checkpoint 2

Design reduced ultimate concrete tensile capacity, ϕN_{urc}

$$\phi N_{urc} = \text{minimum of } \phi N_{ucp} * X_{ncr} * X_{ns} * X_{nc} * X_{ne} * X_{na} \text{ and } \phi N_{ucc} * X_{ncr} * X_{ns} * X_{nc} * X_{ne} * X_{na}$$

STEP 3

Verify anchor tensile capacity - per anchor

Table 3a Reduced characteristic ultimate steel tensile capacity, ϕN_{us} (kN), where $\phi = 0.8$

Anchor size, d_b	10	12	16	20	24	32
Gr 500 Rebar	31.4	45.2	80.4	125.6	196.4	321.6

Checkpoint 3

Design reduced ultimate tensile capacity, ϕN_{ur}

$$\phi N_{ur} = \text{minimum of } \phi N_{urc} \text{ or } \phi N_{us}$$

Check $N^*/\phi N_{ur} \leq 1.0$,

if not satisfied return to step 1

EPCON™ C6 PLUS

STRENGTH LIMIT STATE DESIGN

AVAILABLE IN NEW ZEALAND ONLY

Chemical Anchoring - Reinforcing Bar Anchorage

STEP 4

Step 4 - Verify Concrete Edge Shear Resistance - per anchor

Table 4a-1 Reduced characteristic ultimate concrete edge shear capacity, ϕV_{uc} (kN), $\phi = 1/1.5 = 0.67$, $f'_c = 32$ MPa

Rebar size, d_b	10	12	16	20	25	32
Effective depth, h (mm)	70 - 200	90 - 240	120 - 320	150 - 400	180 - 500	240 - 640
Edge distance, e						
40	4.3	4.7	5.5			
50				8.2	9.2	
70						16.1

For optimised performance data, please use Ramset iExpert Anchoring Software.

Table 4a-2 Cracked Concrete effect, shear, X_{vcr}

Anchor size, d_b	10	12	16	20	25	32
X_{vcr}	0.70					

For Non-cracked concrete $X_{vcr} = 1.0$

Table 4b - Concrete compressive strength effect, shear, X_{vc}

f'_c (MPa)	20	25	32	40	50
X_{vc}	0.79	0.86	1	1.11	1.22

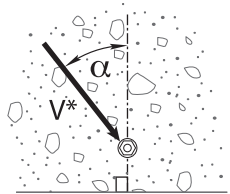

Load direction effect, conc. edge shear, X_{vd}

Table 4c - Concrete load direction effect, concrete edge shear, X_{vd}

Angle, α°	0-55	60	70	80	90-180
X_{vd}	1	1.1	1.2	1.5	2

Table 4d - Concrete anchor spacing and edge distance effect, concrete edge shear, X_{ve}

For single anchor fastening X_{ve}

e/e_m	1.0	1.2	1.4	1.6	1.8	2.0	2.2	2.4	2.6	2.8	3.0	3.2
X_{ve}	1.00	1.31	1.66	2.02	2.41	2.83	3.26	3.72	4.19	4.69	5.20	5.72

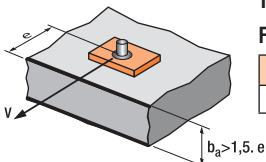

$$X_{ve} = e/e_m * \sqrt{e/e_m}$$

For 2 anchors fastening X_{ve}

e/e_m	1.0	1.2	1.4	1.6	1.8	2.0	2.2	2.4	2.6	2.8	3.0	3.2
a/e_m												
1.0	0.67	0.84	1.03	1.22	1.43	1.65	1.88	2.12	2.36	2.62	2.89	3.16
1.5	0.75	0.93	1.12	1.33	1.54	1.77	2.00	2.25	2.50	2.76	3.03	3.31
2.0	0.83	1.02	1.22	1.43	1.65	1.89	2.12	2.38	2.63	2.90	3.18	3.46
2.5	0.92	1.11	1.32	1.54	1.77	2.00	2.25	2.50	2.77	3.04	3.32	3.61
3.0	1.00	1.20	1.42	1.64	1.88	2.12	2.37	2.63	2.90	3.18	3.46	3.76
3.5		1.30	1.52	1.75	1.99	2.24	2.50	2.76	3.04	3.32	3.61	3.91
4.0			1.62	1.86	2.10	2.36	2.62	2.89	3.17	3.46	3.75	4.05
4.5				1.96	2.21	2.47	2.74	3.02	3.31	3.60	3.90	4.20
5.0					2.33	2.59	2.87	3.15	3.44	3.74	4.04	4.35
5.5						2.71	2.99	3.28	3.71	4.02	4.33	4.65
6.0							2.83	3.11	3.41	3.71	4.02	4.33

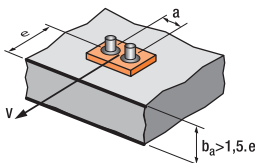

$$X_{ve} = \frac{3*e + a}{6*e_m} * \sqrt{e/e_m}$$

For 3 anchors fastening and more

$$X_{ve} = \frac{3*e + a_1 + a_2 + a_3 + \dots + a_{n-1}}{3*n*e_m} * \sqrt{e/e_m}$$

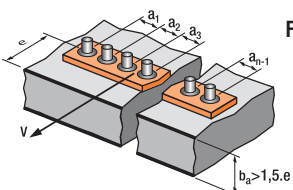

EPCON™ C6 PLUS

STRENGTH LIMIT STATE DESIGN

AVAILABLE IN NEW ZEALAND ONLY

Chemical Anchoring - Reinforcing Bar Anchorage

Table 4e Reduced characteristic ultimate concrete pryout capacity, ϕV_{ucp} (kN), $\phi = 1/1.5 = 0.67$, $f'_c = 32$ MPa

Rebar size, d_b	10	12	16	20	25	32
Effective depth, h (mm)	90	110	125	170	210	300
-40 °C to +70 °C	40.8	59.9	83.8	142.4	219.9	268.1

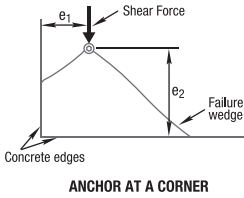

Table 4f Anchor at a corner effect, concrete edge shear, X_{vs}

Note: For $e_1/e_2 > 1.25$, $X_{VS} = 1.0$

Edge distance, e_2 (mm)	25	30	35	50	60	75	125	200	300	400	600	900
Edge distance, e_1 (mm)												
25	0.86	0.77	0.70	0.58	0.53	0.49	0.41	0.37	0.35	0.34	0.32	0.32
30	0.97	0.86	0.78	0.64	0.58	0.52	0.43	0.38	0.36	0.34	0.33	0.32
35	1.00	0.95	0.86	0.69	0.63	0.56	0.46	0.40	0.37	0.35	0.33	0.32
50	1.00	1.00	1.00	0.86	0.77	0.67	0.52	0.44	0.39	0.37	0.35	0.33
60	1.00	1.00	1.00	0.97	0.86	0.75	0.57	0.47	0.41	0.38	0.36	0.34
75	1.00	1.00	1.00	1.00	1.00	0.86	0.64	0.51	0.44	0.41	0.37	0.35
125	1.00	1.00	1.00	1.00	1.00	1.00	0.86	0.65	0.53	0.48	0.42	0.38
200	1.00	1.00	1.00	1.00	1.00	1.00	1.00	0.86	0.67	0.58	0.49	0.42
300	1.00	1.00	1.00	1.00	1.00	1.00	1.00	1.00	0.86	0.72	0.58	0.49
400	1.00	1.00	1.00	1.00	1.00	1.00	1.00	1.00	1.00	0.86	0.67	0.55
500	1.00	1.00	1.00	1.00	1.00	1.00	1.00	1.00	1.00	1.00	0.77	0.61
600	1.00	1.00	1.00	1.00	1.00	1.00	1.00	1.00	1.00	1.00	0.86	0.67
900	1.00	1.00	1.00	1.00	1.00	1.00	1.00	1.00	1.00	1.00	1.00	0.86

Checkpoint **4a**

Design reduced ultimate concrete edge shear capacity, ϕV_{urc}

$$\phi V_{urc} = \phi V_{uc} * X_{vcr} * X_{vc} * X_{vd} * X_{ve} * X_{vs}$$

Checkpoint **4b**

Design reduced ultimate concrete pryout capacity, ϕV_{urcp}

$$\phi V_{urcp} = \phi V_{ucp} * X_{ncr} * X_{nc} * X_{ne} * X_{na}$$

STEP 5

Verify anchor shear capacity - per anchor

Table 5a Reduced characteristic ultimate steel shear capacity, ϕV_{us} (kN) where $\phi_v = 0.67$

Anchor size, d_b	10	12	16	20	25	32
Gr 500 Rebar	21.4	30.8	54.8	85.7	133.9	219.3

Checkpoint **5**

Design reduced ultimate shear capacity, ϕV_{ur}

$$\phi V_{ur} = \text{minimum of } \phi V_{urc} \phi V_{urcp} \phi V_{us}$$

Check $V^*/\phi V_{ur} \leq 1.0$,

if not satisfied return to step 1

EPCON™ C6 PLUS

STRENGTH LIMIT STATE DESIGN

AVAILABLE IN NEW ZEALAND ONLY

Chemical Anchoring - Reinforcing Bar Anchorage

STEP 6 Combined loading and specification

Checkpoint 6

Check
 $N^*/\phi N_{ur} + V^*/\phi V_{ur} \leq 1.2,$
if not satisfied return to step 1

Specify - Reinforcing Bar Anchorage
Ramset EPCON™ C6 PLUS Injection (Anchor Size) grade 500 Rebar.
Drilled hole depth to be (h) mm.

Example
Ramset EPCON™ C6 PLUS Injection with 16mm grade 500 Rebar
Drilled hole depth to be 125 mm.
To be installed in accordance with Ramset Installation Instructions.

Ramset™ iExpert Anchor Software for optimised calculation or where a greater range of anchor layout detail is needed.

ChemSet™ 801 Xtrem™ XC²

CHEMICAL INJECTION - NON-CRACKED & CRACKED CONCRETE

[Back to index](#)

GENERAL INFORMATION

Performance Related	Installation Related

Product

Chemset™ 801 Xtrem™ XC² is a heavy duty Vinylester for anchoring threaded studs and reinforcing bar into cracked and uncracked concrete.

Compliance

European Technical Assessment (option 1) - ETA-18/0045

Design according to:

- AS5216 (formerly TS101)
- EN1992-4 (formerly ETAG001 Annex C, E & TR045)
- Use enclosed data for simplified calculation method

Use Ramset™ iExpert Anchor Software for optimised calculation or where a greater range of anchor layout detail is needed.

Benefits, Advantages and Features

- 50 year working Life
- Flooded Holes
- Fire rated

Greater productivity:

- Easy dispensing even in cold weather
- Apply torque in 2 hours @ 20°C

Greater security:

- Strong bond
- Rated for sustained loading

Versatile:

- Earthquake, Fire & Flooded Conditions
- Cold and temperate climates

Greater safety:

- Low odour
- Suitable for contact with drinking water
- VOC Compliant

Made in Australia

Installation

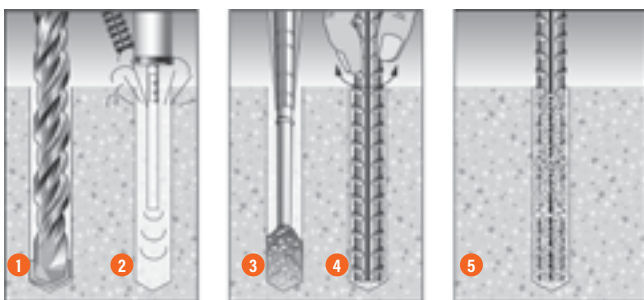

1. Drill or core hole to specified diameter and depth
2. **Important:** Use Ramset™ Dustless Drilling System to ensure holes are clean. Alternatively, clean dust and debris from hole with stiff wire or nylon brush and blower in the following sequence: blow x 2, brush x 2, blow x 2.
3. Screw mixing nozzle onto cartridge and dispense 2-3 trigger pulls of adhesive to waste until colour is grey with no streaks
4. Insert tip of nozzle to bottom of hole and dispense adhesive
5. Fill hole to about 2/3 full
6. Insert reinforcing bar with rotating motion to release trapped air
7. Wait until adhesive has fully cured before loading (see Working Time / Loading Time chart)
8. Clean up with Acetone



Principal Applications

- Threaded Studs
- Starter Bars
- Threaded Inserts
- Over-head installation
- Steel Columns
- Hand Rails
- Road Stitching

Recommended Installation Temperatures

	Minimum	Maximum
Substrate	5°C	40°C
Adhesive	5°C	40°C

Service Temperature Limits

-40°C to 80°C

Setting Times

Temperature of base material	Gel Time	Curing time in dry concrete	Curing time in wet concrete
+5°C	60 min	240 min	480 min
6°C - 10°C	40 min	180 min	360 min
11°C - 20°C	15 min	120 min	240 min
21°C - 30°C	8 min	90 min	180 min
31°C - 40°C	4 min	60 min	120 min

Note: Cartridge temperature minimum +5°C

ChemSet™ 801 Xtrem™ XC²

CHEMICAL INJECTION - NON-CRACKED & CRACKED CONCRETE

Chemical Anchoring - Reinforcing Bar Anchorage

Installation and performance details: ChemSet™ 801 Xtrem™ XC² and Reinforcing Bar

Anchor Size, d _a (mm)	Drilled Hole diam., d _h (mm)	Anchor Effective Depth, h (mm)	Optimum dimensions*			Reduced Characteristic Capacity #				
			Edge* distance, e _c (mm)	Anchor spacing, a _c (mm)	Concrete substrate thickness, b _m (mm)	Gr 500 Rebar - Steel		Non-Cracked Concrete		
						Tension, φN _{us} (kN)***	Shear, φV _{us} (kN)	Tension, φN _{uc} (kN)**		
								Concrete compressive strength, f' _c		
20 MPa	32 MPa	40 MPa								
10	12	90	135	270	115	31.4	21.4	24.5	25.5	26.2
12	15	110	165	330	140	45.2	30.8	35.9	37.4	38.5
16	20	125	187	375	160	80.4	54.8	54.5	56.6	58.3
20	25	150	225	450	190	125.6	85.7	60.2	76.2	85.4
		170	255	510	215			72.6	91.9	99.1

* Note: For shear loads acting towards an edge or where these optimum dimensions are not achievable, please use the simplified strength limit state design process to verify capacity.
 **Note: Reduced characteristic ultimate concrete tensile capacity = φN_{uc} where φ = 0.67 and N_{uc} = Characteristic ultimate concrete tensile capacity.
 For conversion to Working Load Limit MULTIPLY φN_{uc} x 0.5
 ***Note: Reduced characteristic ultimate steel tensile capacity = φN_{us} where φ = 0.8 and N_{us} = Characteristic ultimate steel tensile capacity .
 For conversion to Working Load Limit MULTIPLY φN_{us} x 0.56
 #Note: Design Tensile Capacity φN_{ur} = minimum of φN_{uc} and φN_{us}
 For Cracked Concrete performance, please use the simplified strength limit state design process to verify capacity.
 Data is based on a Service temperature limit of -40°C to +40°C
 Flooded Holes: Multiply φNuc x 0.75
 For optimised performance data, please use Ramset iExpert Anchoring Software.

DESCRIPTION AND PART NUMBERS

Description	Cartridge Size	Part No.
ChemSet™ 801 Xtrem™	750 ml	C801X750 (AU & NZ)
ChemSet™ 801 Xtrem™	380 ml	C801X380 (AU only)

Drilled hole depth, h1 (mm) h1 = h h = Effective depth	Substrate thickness b _m (mm)				
	Anchor Stud Size (mm)				
	10	12	16	20	24
	h + 30mm ≥ 100mm			h + (2 x d _a)	

Typical Engineering Properties of Grade 500 Reinforcing Bar

Rebar Size	10	12	16	20
Drilled Hole Dia, d _h (mm)	12	15	20	25
Stress Area, A _s (mm ²)	78.5	113	201	314
Yield Stress, f _{sy} (MPa)	500	500	500	500
Tensile Steel Yield Capacity, N _{sy} (kN)	39.3	56.5	100.5	157.0

For further information refer to reinforcing bar manufacturer's published information and current revision of AS/NZS 4671

ChemSet™ 801 Xtrem™ XC²

STRENGTH LIMIT STATE DESIGN

STEP 1

Select anchor to be evaluated

Table 1a Indicative combined loading - interaction diagram

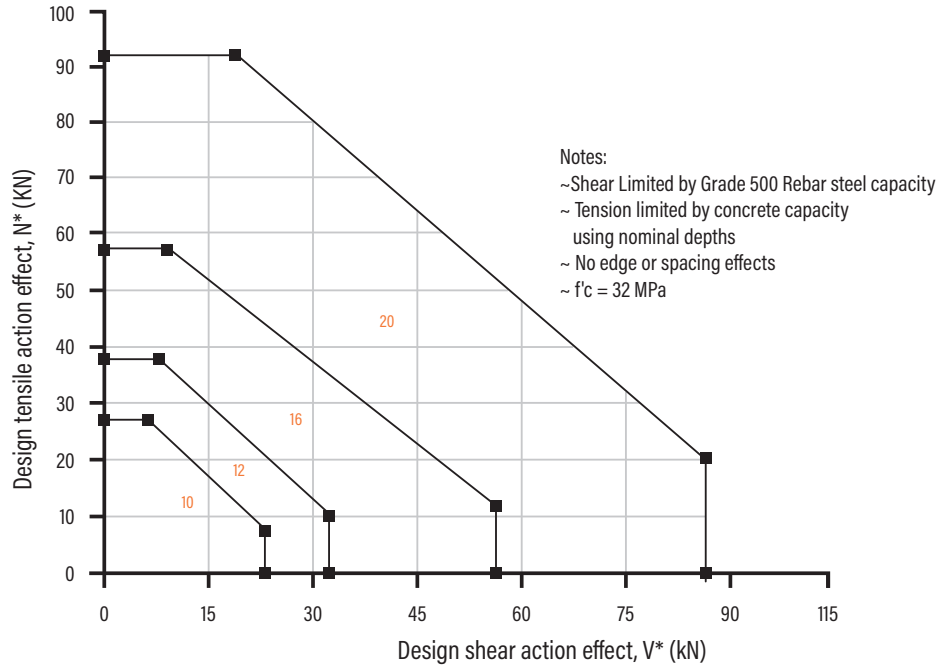

Table 1b Absolute minimum edge distance and anchor spacing values, e_m and a_m (mm)

Rebar size, d _b	10	12	16	20
Min. Anchor Spacing - a _m	50	60	80	100
Min. Edge Distance - e _m	45	45	50	65

Step 1c Calculate anchor effective depth, h (mm)

Refer to nominal recommended effective depths, h, listed in installation and performance details table on previous page.

<p>Effective depth, h (mm)</p> <p>Preferred $h = h_n$ otherwise,</p> <p>$h = L_e - t$</p> <p>t = total thickness of material(s) being fastened.</p>	Substrate thickness b _m (mm)			
	Anchor Stud Size (mm)			
	10	12	16	20
	h + 30mm ≥ 100mm		h + (2 x d _b)	

Checkpoint 1

Anchor size determined, absolute minima compliance achieved, effective depth (h) calculated.

ChemSet™ 801 Xtrem™ XC²

STRENGTH LIMIT STATE DESIGN

Chemical Anchoring - Reinforcing Bar Anchorage

STEP 2 Verify concrete tensile capacity - per anchor

Table 2a Reduced characteristic ultimate concrete tensile capacity, ϕN_{uc} (kN), $\phi_c = 1/1.5 = 0.67$, $f'_c = 32$ MPa

Rebar Size, d_b	Combined pull-out and concrete cone resistance - ϕN_{ucp}				Concrete Cone Resistance - ϕN_{ucc}
	10	12	16	20	
Drilled Hole Dia, d_h (mm)	12	15	20	25	
Effective Depth, h (mm)					
70	19.8				24.3
80	22.7				29.7
90	25.5	30.6			35.4
100	28.3	34.0			41.5
110	31.1	37.4			47.9
120	34.0	40.8	54.4		54.5
125	35.4	42.5	56.6		58.0
140	39.6	47.6	63.4		68.7
150	42.5	51.0	68.0	84.9	76.2
160	45.3	54.4	72.5	90.6	84.0
170	48.1	57.8	77.0	96.3	91.9
180	51.0	61.2	81.6	101.9	100.2
190	53.8	64.6	86.1	107.6	108.6
200	56.6	68.0	90.6	113.3	117.3
210		71.4	95.1	118.9	126.2
240		81.6	108.7	135.9	154.2
270			122.3	152.9	184.0
280			126.9	158.6	194.4
300			135.9	169.9	215.6
320			145.0	181.2	237.5
350				198.2	271.6
400				226.5	331.9

For optimised performance data, please use Ramset iExpert Anchoring Software.

Table 2a-2 Cracked Concrete effect, tension, X_{ncr}

Rebar Size, d_b	Cracked Concrete Effect - X_{ncr}				X_{ncr}
	where $\phi N_{uc} = \phi N_{ucp}$ (from Table 2a)				
f'c (MPa)					where $\phi N_{uc} = \phi N_{ucc}$ (from Table 2a)
20 to 50	0.38	0.42	0.42	0.46	0.70

Bold values are at Chemset Anchor Stud nominal Depths

Flooded Holes: Multiply ϕN_{uc} x 0.75

For Sustained Loads MULTIPLY ϕN_{uc} x 0.6

For Non-cracked concrete $X_{ncr} = 1$.

Note: The maximum embedment depth shall be reduced to $12d_b$ for installation in flooded holes

If concrete condition is Non-Cracked then, Refer to Checkpoint 2	If concrete condition is Cracked then, $\phi N_{uc} = \phi N_{ucp}$
--	---

Table 2b-1 Concrete service temperature limits effect, tension, X_{nts}

Rebar Size, d_b	Service temperature limits effect, tension, X_{nts}				X_{nts}
	where $\phi N_{uc} = \phi N_{ucp}$ (from Table 2a)				
Service temperature (°C)					where $\phi N_{uc} = \phi N_{ucc}$ (from Table 2a)
-40 °C to +40 °C			1.00		1.00
-40 °C to +80 °C			0.92		1.00

Table 2b-2 Concrete compressive strength effect, tension, X_{nc}

NON- CRACKED	Non-Cracked Concrete - X_{nc}				X_{nc}
	where $\phi N_{uc} = \phi N_{ucp}$ (from Table 2a)				
Rebar Size, d_b	10	12	16	20	where $\phi N_{uc} = \phi N_{ucc}$ (from Table 2a)
f'c (MPa)					
20	0.96	0.96	0.96	0.96	0.79
25	0.96	0.96	0.96	0.96	0.88
32	1.00	1.00	1.00	1.00	1.00
40	1.03	1.03	1.03	1.03	1.12
50	1.05	1.05	1.05	1.05	1.25

CRACKED	Cracked Concrete - X_{nc}				X_{nc}
	where $\phi N_{uc} = \phi N_{ucp}$ (from Table 2a)				
Rebar Size, d_b	10	12	16	20	where $\phi N_{uc} = \phi N_{ucc}$ (from Table 2a)
f'c (MPa)					
20 - 50	0.96	0.96	0.96	0.96	0.79

ChemSet™ 801 Xtrem™ XC²

STRENGTH LIMIT STATE DESIGN

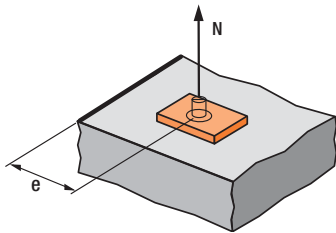

$X_{ne} = 0.25 + 0.5 \cdot (e/h)$
 Where $e_m \leq e \leq e_c$
 $e_c = 1.5 \cdot h$
 Note: Tabled values are based on the nominal effective depth, h shown in the installation details. For other values of X_{ne} , please use equation shown above.

Table 2c - Concrete Edge distance effect, tension, X_{ne}

Anchor size, d_b	10	12	16	20
Edge distance, e (mm)				
45	0.50	0.45		
50	0.53	0.48	0.45	
65	0.61	0.55	0.51	0.44
85	0.72	0.64	0.59	0.50
90	0.75	0.66	0.61	0.51
100	0.81	0.70	0.65	0.54
120	0.92	0.80	0.73	0.60
135	1	0.86	0.79	0.65
165		1	0.91	0.74
187			1	0.80
255				1

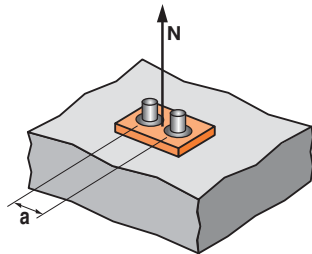

$X_{na} = 0.5 + a/(6 \cdot h)$
 Where $a_m \leq a \leq a_c$
 $a_c = 3 \cdot h$
 Note: Tabled values are based on the nominal effective depth, h shown in the installation details. For other values X_{na} , please use equation shown above.

Table 2d - Concrete anchor spacing effect, tension, X_{na}

Anchor size, d_b	10	12	16	20
Anchor spacing, a (mm)				
50	0.59			
60	0.61	0.59		
80	0.65	0.62	0.61	
100	0.69	0.65	0.63	0.60
120	0.72	0.68	0.66	0.62
150	0.78	0.73	0.70	0.65
200	0.87	0.80	0.77	0.70
270	1	0.91	0.86	0.76
330		1	0.94	0.82
375			1	0.87
510				1

Checkpoint 2

Design reduced ultimate concrete tensile capacity, ϕN_{urc}

$$\phi N_{urc} = \phi N_{uc} \cdot X_{ncr} \cdot X_{ns} \cdot X_{nc} \cdot X_{ne} \cdot X_{na}$$

If concrete condition is Non-Cracked then

$$\phi N_{urc} = \text{minimum of } \phi N_{ucp} \cdot X_{ncr} \cdot X_{ns} \cdot X_{nc} \cdot X_{ne} \cdot X_{na} \text{ and } \phi N_{ucc} \cdot X_{ncr} \cdot X_{ns} \cdot X_{nc} \cdot X_{ne} \cdot X_{na}$$

STEP 3

Checkpoint 3

Verify anchor tensile capacity - per anchor

Table 3a Reduced characteristic ultimate steel tensile capacity, ϕN_{us} (kN), where $\phi = 0.8$

Anchor size, d_b	10	12	16	20
Gr 500 Rebar	31.4	45.2	80.4	125.6

Design reduced ultimate tensile capacity, ϕN_{ur}

$$\phi N_{ur} = \text{minimum of } \phi N_{urc}, \phi N_{us}$$

Check $N^*/\phi N_{ur} \leq 1.0$,

if not satisfied return to step 1

ChemSet™ 801 Xtrem™ XC²

STRENGTH LIMIT STATE DESIGN

Chemical Anchoring - Reinforcing Bar Anchorage

STEP 4

Step 4 - Verify Concrete Shear Capacity - per anchor

Table 4a-1 Reduced characteristic ultimate concrete edge shear capacity, ϕV_{uc} (kN), $\phi = 1/1.5 = 0.67$, $f'_c = 32$ MPa

Rebar size, d_b	10	12	16	20
Effective depth, h (mm)	70 - 200	90 - 240	120 - 320	150 - 400
Edge distance, e_m				
45	5.0	5.5		
50			7.2	
65				11.1

For optimised performance data, please use Ramset iExpert Anchoring Software.

Table 4a-2 Cracked Concrete effect, shear, X_{vcr}

Anchor size, d_b	10	12	16	20
X_{vcr}	0.70			

For Non-cracked concrete $X_{vcr} = 1.0$

Table 4b - Concrete compressive strength effect, shear, X_{vc}

f'_c (MPa)	20	25	32	40	50
X_{vc}	0.79	0.86	1.0	1.11	1.22

Table 4c - Concrete load direction effect, concrete edge shear, X_{vd}

Angle, α°	0-55	60	70	80	90-180
X_{vd}	1	1.1	1.2	1.5	2

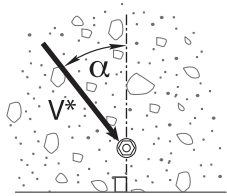

Load direction effect, conc. edge shear, X_{vd}

Table 4d - Concrete anchor spacing and edge distance effect, concrete edge shear, X_{ve}

For single anchor fastening X_{ve}

e/e_m	1.0	1.2	1.4	1.6	1.8	2.0	2.2	2.4	2.6	2.8	3.0	3.2
X_{ve}	1.00	1.31	1.66	2.02	2.41	2.83	3.26	3.72	4.19	4.69	5.20	5.72

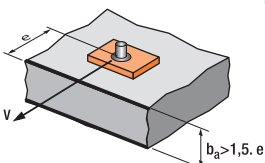

$$X_{ve} = e/e_m * \sqrt{e/e_m}$$

For 2 anchors fastening X_{ve}

e/e_m	1.0	1.2	1.4	1.6	1.8	2.0	2.2	2.4	2.6	2.8	3.0	3.2
a/e_m												
1.0	0.67	0.84	1.03	1.22	1.43	1.65	1.88	2.12	2.36	2.62	2.89	3.16
1.5	0.75	0.93	1.12	1.33	1.54	1.77	2.00	2.25	2.50	2.76	3.03	3.31
2.0	0.83	1.02	1.22	1.43	1.65	1.89	2.12	2.38	2.63	2.90	3.18	3.46
2.5	0.92	1.11	1.32	1.54	1.77	2.00	2.25	2.50	2.77	3.04	3.32	3.61
3.0	1.00	1.20	1.42	1.64	1.88	2.12	2.37	2.63	2.90	3.18	3.46	3.76
3.5		1.30	1.52	1.75	1.99	2.24	2.50	2.76	3.04	3.32	3.61	3.91
4.0			1.62	1.86	2.10	2.36	2.62	2.89	3.17	3.46	3.75	4.05
4.5				1.96	2.21	2.47	2.74	3.02	3.31	3.60	3.90	4.20
5.0					2.33	2.59	2.87	3.15	3.44	3.74	4.04	4.35
5.5						2.71	2.99	3.28	3.71	4.02	4.33	4.65
6.0							2.83	3.11	3.41	3.71	4.02	4.33

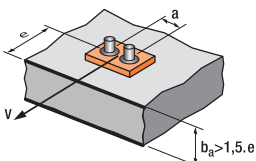

$$X_{ve} = \frac{3*e + a}{6*e_m} * \sqrt{e/e_m}$$

For 3 anchors fastening and more

$$X_{ve} = \frac{3*e + a_1 + a_2 + a_3 + \dots + a_{n-1}}{3*n*e_m} * \sqrt{e/e_m}$$

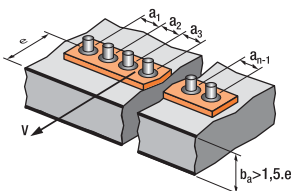

ChemSet™ 801 Xtrem™ XC²

STRENGTH LIMIT STATE DESIGN

Table 4e Reduced characteristic ultimate concrete pryout capacity, ϕV_{ucp} (kN), $\phi = 1/1.5 = 0.67$, $f'_c = 32$ MPa

Rebar size, d_b	10	12	16	20
Effective depth, h (mm)	90	110	125	170
-40 °C to +40 °C	51.0	74.8	158.6	192.6
-40 °C to +80 °C	47.0	69.0	104.6	177.7

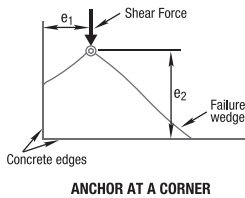

Table 4f Anchor at a corner effect, concrete edge shear, X_{vs}

Note: For $e_1/e_2 > 1.25$, $X_{vs} = 1.0$

Edge distance, e_2 (mm)	25	30	35	50	60	75	125	200	300	400	600	900
Edge distance, e_1 (mm)												
25	0.86	0.77	0.70	0.58	0.53	0.49	0.41	0.37	0.35	0.34	0.32	0.32
30	0.97	0.86	0.78	0.64	0.58	0.52	0.43	0.38	0.36	0.34	0.33	0.32
35	1.00	0.95	0.86	0.69	0.63	0.56	0.46	0.40	0.37	0.35	0.33	0.32
50	1.00	1.00	1.00	0.86	0.77	0.67	0.52	0.44	0.39	0.37	0.35	0.33
60	1.00	1.00	1.00	0.97	0.86	0.75	0.57	0.47	0.41	0.38	0.36	0.34
75	1.00	1.00	1.00	1.00	1.00	0.86	0.64	0.51	0.44	0.41	0.37	0.35
125	1.00	1.00	1.00	1.00	1.00	1.00	0.86	0.65	0.53	0.48	0.42	0.38
200	1.00	1.00	1.00	1.00	1.00	1.00	1.00	0.86	0.67	0.58	0.49	0.42
300	1.00	1.00	1.00	1.00	1.00	1.00	1.00	1.00	0.86	0.72	0.58	0.49
400	1.00	1.00	1.00	1.00	1.00	1.00	1.00	1.00	1.00	0.86	0.67	0.55
500	1.00	1.00	1.00	1.00	1.00	1.00	1.00	1.00	1.00	1.00	0.77	0.61
600	1.00	1.00	1.00	1.00	1.00	1.00	1.00	1.00	1.00	1.00	0.86	0.67
900	1.00	1.00	1.00	1.00	1.00	1.00	1.00	1.00	1.00	1.00	1.00	0.86

Checkpoint **4a**

Design reduced ultimate concrete edge shear capacity, ϕV_{urc}

$$\phi V_{urc} = \phi V_{uc} * X_{vcr} * X_{vc} * X_{vd} * X_{ve} * X_{vs}$$

Checkpoint **4b**

Design reduced ultimate concrete pryout capacity, ϕV_{urcp}

$$\phi V_{urcp} = \phi V_{ucp} * X_{ncr} * X_{nc} * X_{ne} * X_{na}$$

STEP 5

Verify anchor shear capacity - per anchor

Table 5a Reduced characteristic ultimate steel shear capacity, ϕV_{usr} (kN) where $\phi_v = 0.8$

Anchor size, d_b	10	12	16	20
Gr 500 Rebar	21.4	30.8	54.8	85.7

Checkpoint **5**

Design reduced ultimate shear capacity, ϕV_{ur}

$$\phi V_{ur} = \text{minimum of } \phi V_{urc}, \phi V_{urcp}, \phi V_{usr}$$

Check $V^*/\phi V_{ur} \leq 1$,

if not satisfied return to step 1

ChemSet™ 801 Xtrem™ XC²

STRENGTH LIMIT STATE DESIGN

STEP 6 Combined loading and specification

Checkpoint 6

Check

$N^*/\phi N_{ur} + V^*/\phi V_{ur} \leq 1.2$,
if not satisfied return to step 1

Specify - Reinforcing Bar Anchorage

Ramset 801 Xtrem™ XC² Injection (Anchor
Size) grade 500 Rebar.
Drilled hole depth to be (h) mm.

Example

Ramset 801 Xtrem™ XC² Injection with
20mm grade 500 Rebar
Drilled hole depth to be 125 mm.
To be installed in accordance with
Ramset Installation Instructions.

Ramset™ iExpert Anchor Software for optimised calculation or where a greater range of anchor layout detail is needed.

ChemSet™ 101 PLUS

CHEMICAL INJECTION - NON-CRACKED CONCRETE

GENERAL INFORMATION

Performance Related	Installation Related

Product

ChemSet™ Injection 101 PLUS is a marine grade polyester adhesive anchor.



Benefits, Advantages and Features

Fast installation:

- Load in 50 minutes (at 20°C)
- Easy cold weather dispensing

Versatile:

- Suitable for anchoring into a wide variety of substrates
- Solid concrete, hollow block and brick
- Flooded holes
- Styrene Free
- Cold and temperate climates
- VOC Compliant

Ramset Design Method:

- Uses technical data validated from testing in ANZ concrete

Australian Made



Principal Applications

- Hollow brick and block
- Stadium seating
- Starter Bars
- Balustrades

Recommended Installation Temperatures

	Minimum	Maximum
Substrate	5°C	40°C
Adhesive	5°C	40°C

Installation

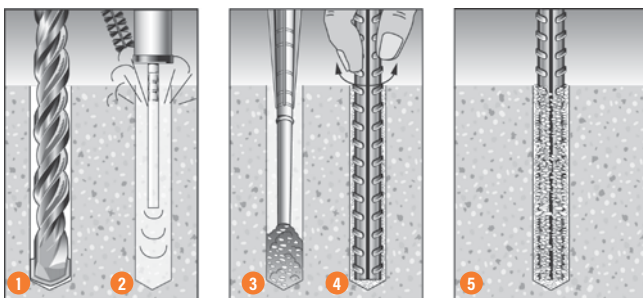

1. Drill recommended diameter and depth hole.
2. **Important:** Use Ramset™ Dustless Drilling System to ensure holes are clean. Alternatively, clean dust and debris from hole with stiff wire or nylon brush and blower in the following sequence: blow x 4, brush x 3, blow x 4, brush x 3, blow x 4.
3. Dispense adhesive to waste until colour is uniform light grey (2-3 trigger pulls). Insert mixing nozzle to bottom of hole. Fill hole to 3/4 the hole depth slowly, ensuring no air pockets form.
4. Insert rebar to bottom of hole while turning.
5. ChemSet™ Injection to cure as per setting times.

Service Temperature Limits

-40°C to 80°C

Setting Times

Temperature of base material	Cartridge Temperature	Gel Time	Curing time in dry and wet concrete
5°C	5°C	18 min	145 min
10°C	10°C	10 min	85 min
20°C	20°C	6 min	50 min
25°C	25°C	5 min	40 min
+30°C	+30°C	5 min	35 min

Note: Cartridge temperature minimum +5°C

ChemSet™ 101 PLUS

CHEMICAL INJECTION - NON-CRACKED CONCRETE

Chemical Anchoring - Reinforcing Bar Anchorage

Installation and performance details: ChemSet™ Injection 101 PLUS and Reinforcing Bar

Anchor Size, d_b (mm)	Drilled Hole diam., d_h (mm)	Anchor Effective Depth, h (mm)	Optimum dimensions*			Reduced Characteristic Capacity #				
			Edge* distance, e_c (mm)	Anchor spacing, a_c (mm)	Concrete substrate thickness, b_m (mm)	Gr 500 Rebar - Steel		Non-cracked Concrete		
						Tension, ϕN_{us} (kN)***	Shear, ϕV_{us} (kN)	Tension, ϕN_{uc} (kN)**		
								Concrete compressive strength, f'_c		
20 MPa	32 MPa	40 MPa								
10	14	90	40	60	115	31.4	21.4	7.8	9.8	11.0
12	16	110	50	70	140	45.2	30.8	11.5	14.5	16.2
16	20	125	65	100	160	80.4	54.8	17.3	21.9	24.5
20	25	150	80	120	190	125.6	85.7	26.0	32.9	36.8
		215			29.5			37.3	41.7	
24	30	180	100	145	240	180.8	123.3	37.5	47.4	53.0
		270			43.7			55.3	61.9	
25	30	180	100	150	240	196.4	133.9	39.1	49.4	55.3
		270			45.6			57.7	64.5	
28	35	225	115	170	295	246.4	168.0	54.7	69.2	77.4
		340			65.6			83.0	92.8	
32	40	240	130	195	320	321.6	219.3	66.7	84.3	94.3
		380			83.4			105.4	117.9	
36	45	290	145	220	380	408.0	278.3	90.6	114.7	128.2
		420			103.2			130.5	145.9	
40	50	320	160	240	420	504.0	343.7	111.1	140.6	157.2
		460			125.0			158.2	176.8	

* Note: For shear loads acting towards an edge or where these optimum dimensions are not achievable, please use the simplified strength limit state design process to verify capacity.
 Note: Reduced characteristic ultimate concrete tensile capacity = ϕN_{uc} where $\phi = 0.6$ and N_{uc} = Characteristic ultimate concrete tensile capacity. **For conversion to Working Load Limit MULTIPLY ϕN_{uc} x 0.55
 ***Note: Reduced characteristic ultimate steel tensile capacity = ϕN_{us} where $\phi = 0.8$ and N_{us} = Characteristic ultimate steel tensile capacity. **For conversion to Working Load Limit MULTIPLY ϕN_{us} x 0.56**
 #Note: Design Tensile Capacity ϕN_{ur} = minimum of ϕN_{uc} and ϕN_{us}
WET HOLES: Multiply ϕN_{uc} x 1 All data relevant for Non-Cracked Concrete
 For optimised performance data, please use Ramset iExpert Anchoring Software.

DESCRIPTION AND PART NUMBERS

Description	Cartridge Size	Part No.
ChemSet™ 101 PLUS Cartridge	380 ml	C101C
ChemSet™ 101 PLUS Jumbo Cartridge	750 ml	C101J
ChemSet™ 101 PLUS Kit	2 x 380 ml	ISKP
Mixer Nozzle for 101 PLUS	-	ISNP

Substrate thickness, b_m (mm)
 $b_m = \text{greater of: } 1.25 \times h, h + (2 \times d_h)$

Drilled hole depth, h_1 (mm)
 $h_1 = h$
 $h = \text{Effective depth}$

TYPICAL ENGINEERING PROPERTIES OF GRADE 500 REINFORCING BAR

Rebar Size	10	12	16	20	24	25	28	32	36	40
Drilled Hole Dia, d_h (mm)	14	16	20	25	30	30	35	40	45	50
Stress Area, A_s (mm ²)	78.5	113	201	314	452	491	616	804	1020	1260
Yield Stress, f_{sy} (MPa)	500	500	500	500	500	500	500	500	500	500
Tensile Steel Yield Capacity N_{sy} (kN)	39.3	56.5	100.5	157.0	226.0	245.5	308.0	402.0	510.0	630.0

For further information refer to reinforcing bar manufacturer's published information and current revision of AS/NZS 4671

ChemSet™ 101 PLUS

STRENGTH LIMIT STATE DESIGN

STEP 1 Select anchor to be evaluated

Table 1a Indicative combined loading - interaction diagram

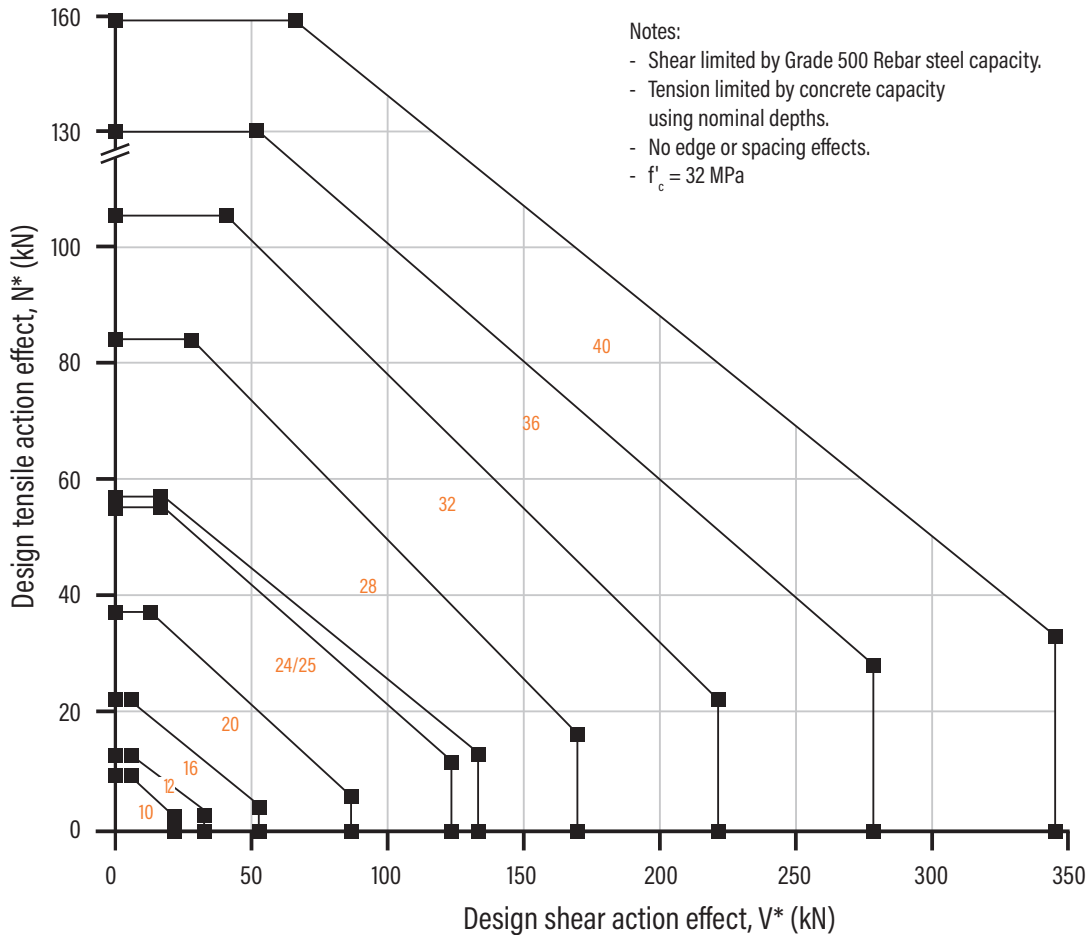

Table 1b Absolute minimum edge distance and anchor spacing values, e_m and a_m (mm)

Anchor size, d_b	10	12	16	20	24	25	28	32	36	40
e_m, a_m	30	36	48	60	72	75	84	96	108	120

Step 1c Calculate anchor effective depth, h (mm)

Refer to nominal recommended effective depths, h , listed in installation and performance details table on previous page.

Effective depth, h (mm)

Preferred $h = h_n$ otherwise

$h = L_e - t$,
 t = total thickness of material(s) being fixed

Substrate thickness, b_m (mm)

$b_m = \text{greater of: } 1.25 \times h, h + (2 \times d_h)$

Checkpoint

1 Anchor size determined, absolute minima compliance achieved, effective depth (h) calculated.

ChemSet™ 101 PLUS

STRENGTH LIMIT STATE DESIGN

Chemical Anchoring - Reinforcing Bar Anchorage

STEP 2 Verify concrete tensile capacity - per anchor

Table 2a Reduced characteristic ultimate concrete tensile capacity, ϕN_{uc} (kN), $\phi_c = 0.6$, $f'_c = 32$ MPa

Anchor size, d_b	10	12	16	20	24	25	28	32	36	40
Drilled Hole Dia, d_h (mm)	14	16	20	25	30	30	35	40	45	50
Effective Depth, h (mm)										
85	9.3									
90	9.8									
95	10.4									
100	10.9	13.1								
105	11.5	13.8								
110	12.0	14.5								
115	12.6	15.1								
125	13.7	16.4	21.9							
140	15.3	18.4	24.6							
150	16.4	19.7	26.3	32.9						
170		22.4	29.8	37.3						
180		23.7	31.6	39.5	47.4	49.4				
210			36.9	46.1	55.3	57.7	64.5			
240			42.2	52.7	63.3	65.9	73.8	84.3		
270				59.3	71.1	74.1	83.0	94.8	106.7	
300				65.9	79.0	82.4	92.2	105.4	118.6	131.7
320				70.2	84.3	87.9	98.4	112.4	126.5	140.5
330					86.9	90.6	101.4	115.9	130.4	144.9
360					94.8	98.8	110.7	126.5	142.3	158.1
420						115.3	129.1	147.6	166.0	184.5
460								161.7	181.8	202.0
500								175.7	197.6	219.6
550									217.4	241.6
600										263.5
625										274.5

Bold values are at ChemSet Anchor Stud nominal depths.

WET HOLES: Multiply $\phi N_{uc} \times 1$

All data relevant for Non-Cracked Concrete. For optimised performance data, please use Ramset iExpert Anchoring Software.

Table 2b Concrete compressive strength effect, tension, X_{nc}

f'_c (MPa)	20	25	32	40	50
X_{nc}	0.79	0.88	1.00	1.12	1.25

Table 2c Edge distance effect, tension, X_{ne}

Anchor size, d_b	10	12	16	20	24	25	28	32	36	40
Edge Distance, e (mm)										
30	0.83									
35	0.91	0.81								
40	1.00	0.88								
50		1.00	0.85							
65			1.00	0.87						
80				1.00	0.88	0.86				
95					1.00	0.97	0.89	0.82		
100						1.00	0.93	0.85		
110							1.00	0.90	0.83	
130								1.00	0.93	0.87
145									1.00	0.93
160										1.00

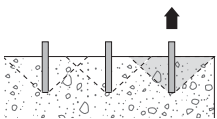

ChemSet™ 101 PLUS

STRENGTH LIMIT STATE DESIGN

Table 2d Anchor spacing effect, end of a row, tension, X_{nae}

For single anchor design, $X_{nae} = 1.0$

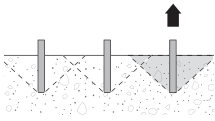

Anchor size, d_b	10	12	16	20	24	25	28	32	36	40
Anchor Spacing, a (mm)										
30	0.75									
35	0.79	0.74								
40	0.83	0.78								
50	0.92	0.85	0.76							
60	1.00	0.92	0.81	0.75						
75		1.00	0.89	0.81	0.76	0.75				
95			1.00	0.90	0.83	0.82	0.78			
120				1.00	0.92	0.90	0.86	0.81	0.78	0.75
140					1.00	0.97	0.92	0.86	0.82	0.79
150						1.00	0.95	0.89	0.85	0.81
170							1.00	0.94	0.89	0.85
195								1.00	0.95	0.91
220									1.00	0.96
240										1.00

Table 2e Anchor spacing effect, internal to a row, tension, X_{nai}

For single anchor design, $X_{nai} = 1.0$

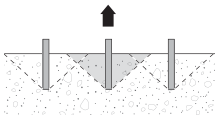

Anchor size, d_b	10	12	16	20	24	25	28	32	36	40
Anchor Spacing, a (mm)										
30	0.50									
35	0.58	0.49								
40	0.67	0.56								
50	0.83	0.69	0.52							
60	1.00	0.83	0.63	0.50						
75		1.00	0.78	0.63	0.52	0.50				
95			1.00	0.79	0.66	0.63	0.57	0.49		
120				1.00	0.83	0.80	0.71	0.63	0.56	0.50
150					1.00	1.00	0.89	0.78	0.69	0.63
170							1.00	0.89	0.79	0.71
195								1.00	0.90	0.81
215									1.00	0.90
240										1.00

Checkpoint

2

Design reduced ultimate concrete tensile capacity, ϕN_{urc}

$$\phi N_{urc} = \phi N_{uc} * X_{nc} * X_{ne} * (X_{nae} \text{ or } X_{nai})$$

STEP

3

Verify anchor tensile capacity - per anchor

Table 3a Reduced characteristic ultimate steel tensile capacity, ϕN_{us} (kN), $\phi_n = 0.8$

Anchor size, d_b	10	12	16	20	24	25	28	32	36	40
e_m, a_m	31.4	45.2	80.4	125.6	180.8	196.4	246.4	321.6	408.8	504.0

ChemSet™ 101 PLUS

STRENGTH LIMIT STATE DESIGN

Chemical Anchoring - Reinforcing Bar Anchorage

Checkpoint 3

Design reduced ultimate tensile capacity, ϕN_{ur}

$$\phi N_{ur} = \text{minimum of } \phi N_{urc}, \phi N_{us}$$

Check $N^* / \phi N_{ur} \leq 1$, if not satisfied return to step 1

Tensile performance conversion table

Performance Required	Concrete Tensile Performance		Steel Tensile Performance	
	Notation	Concrete Tension Capacity	Notation	Carbon Steel Tension Capacity
Strength Limit State	ϕN_{urc}	MULTIPLY $\phi N_{urc} \times 1.00$	ϕN_{us}	MULTIPLY $\phi N_{us} \times 1.00$
Working Load Limit	N_{ac}	MULTIPLY $\phi N_{urc} \times 0.55$	N_{as}	MULTIPLY $\phi N_{us} \times 0.56$
Cyclic Loading	N_{yc}	Refer to page 40 for suitable anchor	N_{ys}	Refer to page 40 for suitable anchor
Fire Resistance	$N_{Rk,c,fi,t}$	Refer to Fire Rated Anchors	$N_{Rk,s,fi,t}$	Refer to Fire Rated Anchors
Seismic	$N_{Rd,p,sis}^0$	Refer to Seismic Anchors	$N_{Rd,s,sis}$	Refer to Seismic Anchors

NOTE: Design Tensile Capacity is the minimum of Concrete Tension and Steel Tension Capacities

STEP 4

Verify concrete shear capacity - per anchor

Table 4a Reduced characteristic ultimate concrete edge shear capacity, ϕV_{uc} (kN), $\phi_q = 0.6$, $f_c = 32$ MPa

Anchor size, d_b	10	12	16	20	24	25	28	32	36	40
Edge Distance, e (mm)										
30	2.5									
35	3.2									
40	3.9	4.2								
50	5.5	5.9	6.5							
60	7.2	7.7	8.6	9.6						
75	10.1	10.8	12.0	13.4	14.7	14.7				
95	14.3	15.3	17.1	19.2	21.0	21.0	22.7			
120	20.4	21.8	24.3	27.2	29.8	29.8	32.2	34.4	36.5	38.5
200	43.8	46.8	52.4	58.6	64.1	64.1	69.3	74.1	78.6	82.8
300	80.5	86.1	96.2	107.6	117.8	117.8	127.3	136.1	144.3	152.1
400	123.9	132.5	148.1	165.6	181.4	181.4	196.0	209.5	222.2	234.2
500	173.2	185.2	207.0	231.5	253.6	253.6	273.9	292.8	310.6	327.4
600	227.7	243.4	272.2	304.3	333.3	333.3	360.0	384.9	408.2	430.3

Note: Effective depth, h must be $\geq 6 \times$ drilled hole diameter, d_h for anchor to achieve tabled shear capacities.

Table 4b Concrete compressive strength effect, concrete edge shear, X_{vc}

f_c (MPa)	20	25	32	40	50
X_{vc}	0.79	0.88	1.00	1.12	1.25

Table 4c Load direction effect, concrete edge shear, X_{vd}

Angle, α°	0	10	20	30	40	50	60	70	80	90-180
X_{vd}	1.00	1.04	1.16	1.32	1.50	1.66	1.80	1.91	1.98	2.00

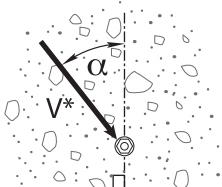

Load direction effect, conc. edge shear, X_{vd}

ChemSet™ 101 PLUS

STRENGTH LIMIT STATE DESIGN

Table 4d Anchor spacing effect, concrete edge shear, X_{va}

Note: For single anchor designs, $X_{va} = 1.0$

Edge distance, e (mm)	25	30	35	50	60	75	125	200	300	400	500	600
Anchor spacing, a (mm)												
25	0.70	0.67	0.64	0.60	0.58	0.57	0.54					
30	0.74	0.70	0.67	0.62	0.60	0.58	0.55	0.53				
35	0.78	0.73	0.70	0.64	0.62	0.59	0.56	0.54	0.52			
50	0.90	0.83	0.79	0.70	0.67	0.63	0.58	0.55	0.53	0.53		
60	0.98	0.90	0.84	0.74	0.70	0.66	0.60	0.56	0.54	0.53	0.52	
75	1.00	1.00	0.93	0.80	0.75	0.70	0.62	0.58	0.55	0.54	0.53	0.53
150			1.00	1.00	1.00	0.90	0.74	0.65	0.60	0.58	0.56	0.55
200						1.00	0.82	0.70	0.63	0.60	0.58	0.57
300							0.98	0.80	0.70	0.65	0.62	0.60
400							1.00	0.90	0.77	0.70	0.66	0.63
500								1.00	0.83	0.75	0.70	0.67
625									0.92	0.81	0.75	0.71
750									1.00	0.88	0.80	0.75
875										0.94	0.85	0.79
1000										1.00	0.90	0.83
1250											1.00	0.92
1500												1.00

Table 4e Multiple anchors effect, concrete edge shear, X_{vn}

Note: For single anchor designs, $X_{vn} = 1.0$

Anchor spacing / Edge distance, a / e	0.20	0.40	0.60	0.80	1.00	1.20	1.40	1.60	1.80	2.00	2.25	2.50
Number of anchors, n												
2	1.00	1.00	1.00	1.00	1.00	1.00	1.00	1.00	1.00	1.00	1.00	1.00
3	0.72	0.76	0.80	0.83	0.86	0.88	0.91	0.93	0.95	0.96	0.98	1.00
4	0.57	0.64	0.69	0.74	0.79	0.82	0.86	0.89	0.92	0.94	0.97	1.00
5	0.49	0.57	0.63	0.69	0.74	0.79	0.83	0.87	0.90	0.93	0.97	1.00
6	0.43	0.52	0.59	0.66	0.71	0.77	0.81	0.85	0.89	0.93	0.96	1.00
7	0.39	0.48	0.56	0.63	0.69	0.75	0.80	0.84	0.88	0.92	0.96	1.00
8	0.36	0.46	0.54	0.61	0.68	0.74	0.79	0.84	0.88	0.92	0.96	1.00
9	0.34	0.44	0.52	0.60	0.67	0.73	0.78	0.83	0.87	0.91	0.96	1.00
10	0.32	0.42	0.51	0.59	0.66	0.72	0.77	0.82	0.87	0.91	0.96	1.00
15	0.26	0.37	0.47	0.55	0.63	0.70	0.76	0.81	0.86	0.90	0.95	1.00
20	0.23	0.35	0.45	0.54	0.61	0.68	0.75	0.80	0.85	0.90	0.95	1.00

Table 4f Anchor at a corner effect, concrete edge shear, X_{vs}

Note: For $e_1/e_2 > 1.25$, $X_{vs} = 1.0$

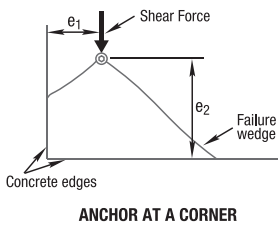

Edge distance, e_2 (mm)	25	30	35	50	60	75	125	200	300	400	600	900
Edge distance, e_1 (mm)												
25	0.86	0.77	0.70	0.58	0.53	0.49	0.41	0.37	0.35	0.34	0.32	0.32
30	0.97	0.86	0.78	0.64	0.58	0.52	0.43	0.38	0.36	0.34	0.33	0.32
35	1.00	0.95	0.86	0.69	0.63	0.56	0.46	0.40	0.37	0.35	0.33	0.32
50	1.00	1.00	1.00	0.86	0.77	0.67	0.52	0.44	0.39	0.37	0.35	0.33
60	1.00	1.00	1.00	0.97	0.86	0.75	0.57	0.47	0.41	0.38	0.36	0.34
75	1.00	1.00	1.00	1.00	1.00	0.86	0.64	0.51	0.44	0.41	0.37	0.35
125	1.00	1.00	1.00	1.00	1.00	1.00	0.86	0.65	0.53	0.48	0.42	0.38
200	1.00	1.00	1.00	1.00	1.00	1.00	1.00	0.86	0.67	0.58	0.49	0.42
300	1.00	1.00	1.00	1.00	1.00	1.00	1.00	1.00	0.86	0.72	0.58	0.49
400	1.00	1.00	1.00	1.00	1.00	1.00	1.00	1.00	1.00	0.86	0.67	0.55
500	1.00	1.00	1.00	1.00	1.00	1.00	1.00	1.00	1.00	1.00	0.77	0.61
600	1.00	1.00	1.00	1.00	1.00	1.00	1.00	1.00	1.00	1.00	0.86	0.67
900	1.00	1.00	1.00	1.00	1.00	1.00	1.00	1.00	1.00	1.00	1.00	0.86

ChemSet™ 101 PLUS

STRENGTH LIMIT STATE DESIGN

Chemical Anchoring - Reinforcing Bar Anchorage

Checkpoint 4

Design reduced ultimate concrete edge shear capacity, ϕV_{urc}

$$\phi V_{urc} = \phi V_{uc} * X_{vc} * X_{vd} * X_{va} * X_{vn} * X_{vs}$$

STEP 5

Verify anchor shear capacity - per anchor

Table 5a Reduced characteristic ultimate steel shear capacity, ϕV_{us} (kN), $\phi_v = 0.8$

Anchor size, d_b	10	12	16	20	24	25	28	32	36	40
Grade 500 Rebar	21.4	30.8	54.8	85.7	123.3	133.9	168.0	219.3	278.3	343.7

Checkpoint 5

Design reduced ultimate shear capacity, ϕV_{ur}

$$\phi V_{ur} = \text{minimum of } \phi V_{urc}, \phi V_{us}$$

Check $V^* / \phi V_{ur} \leq 1$,

if not satisfied return to step 1

Shear performance conversion table

Performance Required	Concrete Shear Performance		Steel Shear Performance	
	Notation	Concrete Shear Capacity	Notation	Carbon Steel Shear Capacity
Strength Limit State	ϕV_{uc}	MULTIPLY $\phi V_{uc} \times 1.00$	ϕV_{us}	MULTIPLY $\phi V_{us} \times 1.00$
Working Load Limit	V_{ac}	MULTIPLY $\phi V_{uc} \times 0.55$	V_{as}	MULTIPLY $\phi V_{us} \times 0.45$
Cyclic Loading	V_{yc}	Refer to page 40 for suitable anchor	V_{ys}	Refer to page 40 for suitable anchor
Fire Resistance	$V_{Rk,c,fi,t}$	Refer to Fire Rated Anchors	$V_{Rk,s,fi,t}$	Refer to Fire Rated Anchors
Seismic	$V_{Rd,c,sis}^0$	Refer to Seismic Anchors	$V_{Rd,s,sis}^0$	Refer to Seismic Anchors

NOTE: Design Shear Capacity is the minimum of Concrete Shear and Steel Shear Capacities

STEP 6

Combined loading and specification

Checkpoint 6

Check

$$N^* / \phi N_{ur} + V^* / \phi V_{ur} \leq 1.2,$$

if not satisfied return to step 1

Specify - Reinforcing Bar Anchorage

Ramset ChemSet 101 PLUS with (Anchor Size) grade 500 Rebar.
Drilled hole depth to be (h) mm.

Example

Ramset™ ChemSet™ 101 PLUS with N20 grade 500 Rebar
Drilled hole depth to be 160 mm.
To be installed in accordance with Ramset™ Installation Instructions.

ChemSet™ 101 PLUS

CHEMICAL INJECTION - NON-CRACKED CONCRETE

Chemical Anchoring - Reinforcing Bar Anchorage

Installation and performance details: ChemSet™ Injection 101 PLUS and Reinforcing Bar

Anchor Size, d_b (mm)	Drilled Hole diam., d_h (mm)	Anchor Effective Depth, h (mm)	Optimum dimensions*			Reduced Characteristic Capacity #				
			Edge* distance, e_c (mm)	Anchor spacing, a_c (mm)	Concrete substrate thickness, b_m (mm)	Gr 500 Rebar - Steel		Non-cracked Concrete		
						Tension, ϕN_{us} (kN)***	Shear, ϕV_{us} (kN)	Tension, ϕN_{uc} (kN)**		
								Concrete compressive strength, f'_c		
20 MPa	32 MPa	40 MPa								
10	14	90	40	60	115	31.4	21.4	7.8	9.8	11.0
12	16	110	50	70	140	45.2	30.8	11.5	14.5	16.2
16	20	125	65	100	160	80.4	54.8	17.3	21.9	24.5
20	25	150	80	120	190	125.6	85.7	26.0	32.9	36.8
		170			29.5			37.3	41.7	
24	30	180	100	145	240	180.8	123.3	37.5	47.4	53.0
		210			43.7			55.3	61.9	
25	30	180	100	150	240	196.4	133.9	39.1	49.4	55.3
		210			45.6			57.7	64.5	
28	35	225	115	170	295	246.4	168.0	54.7	69.2	77.4
		270			65.6			83.0	92.8	
32	40	240	130	195	320	321.6	219.3	66.7	84.3	94.3
		300			83.4			105.4	117.9	
36	45	290	145	220	380	408.0	278.3	90.6	114.7	128.2
		330			103.2			130.5	145.9	
40	50	320	160	240	420	504.0	343.7	111.1	140.6	157.2
		360			125.0			158.2	176.8	

* Note: For shear loads acting towards an edge or where these optimum dimensions are not achievable, please use the simplified strength limit state design process to verify capacity.
 Note: Reduced characteristic ultimate concrete tensile capacity = ϕN_{uc} where $\phi = 0.6$ and N_{uc} = Characteristic ultimate concrete tensile capacity. **For conversion to Working Load Limit MULTIPLY ϕN_{uc} x 0.55
 ***Note: Reduced characteristic ultimate steel tensile capacity = ϕN_{us} where $\phi = 0.8$ and N_{us} = Characteristic ultimate steel tensile capacity. **For conversion to Working Load Limit MULTIPLY ϕN_{us} x 0.56**
 #Note: Design Tensile Capacity ϕN_{ur} = minimum of ϕN_{uc} and ϕN_{us}
WET HOLES: Multiply ϕN_{uc} x 1 All data relevant for Non-Cracked Concrete
 For optimised performance data, please use Ramset iExpert Anchoring Software.

DESCRIPTION AND PART NUMBERS

Description	Cartridge Size	Part No.
ChemSet™ 101 PLUS Cartridge	380 ml	C101C
ChemSet™ 101 PLUS Jumbo Cartridge	750 ml	C101J
ChemSet™ 101 PLUS Kit	2 x 380 ml	ISKP
Mixer Nozzle for 101 PLUS	-	ISNP

Substrate thickness, b_m (mm)
 $b_m = \text{greater of: } 1.25 \times h, h + (2 \times d_h)$

Drilled hole depth, h_1 (mm)
 $h_1 = h$
 $h = \text{Effective depth}$

TYPICAL ENGINEERING PROPERTIES OF GRADE 500 REINFORCING BAR

Rebar Size	10	12	16	20	24	25	28	32	36	40
Drilled Hole Dia, d_h (mm)	14	16	20	25	30	30	35	40	45	50
Stress Area, A_s (mm ²)	78.5	113	201	314	452	491	616	804	1020	1260
Yield Stress, f_{sy} (MPa)	500	500	500	500	500	500	500	500	500	500
Tensile Steel Yield Capacity N_{sy} (kN)	39.3	56.5	100.5	157.0	226.0	245.5	308.0	402.0	510.0	630.0

For further information refer to reinforcing bar manufacturer's published information and current revision of AS/NZS 4671

ChemSet™ 101 PLUS

STRENGTH LIMIT STATE DESIGN

STEP 1 Select anchor to be evaluated

Table 1a Indicative combined loading - interaction diagram

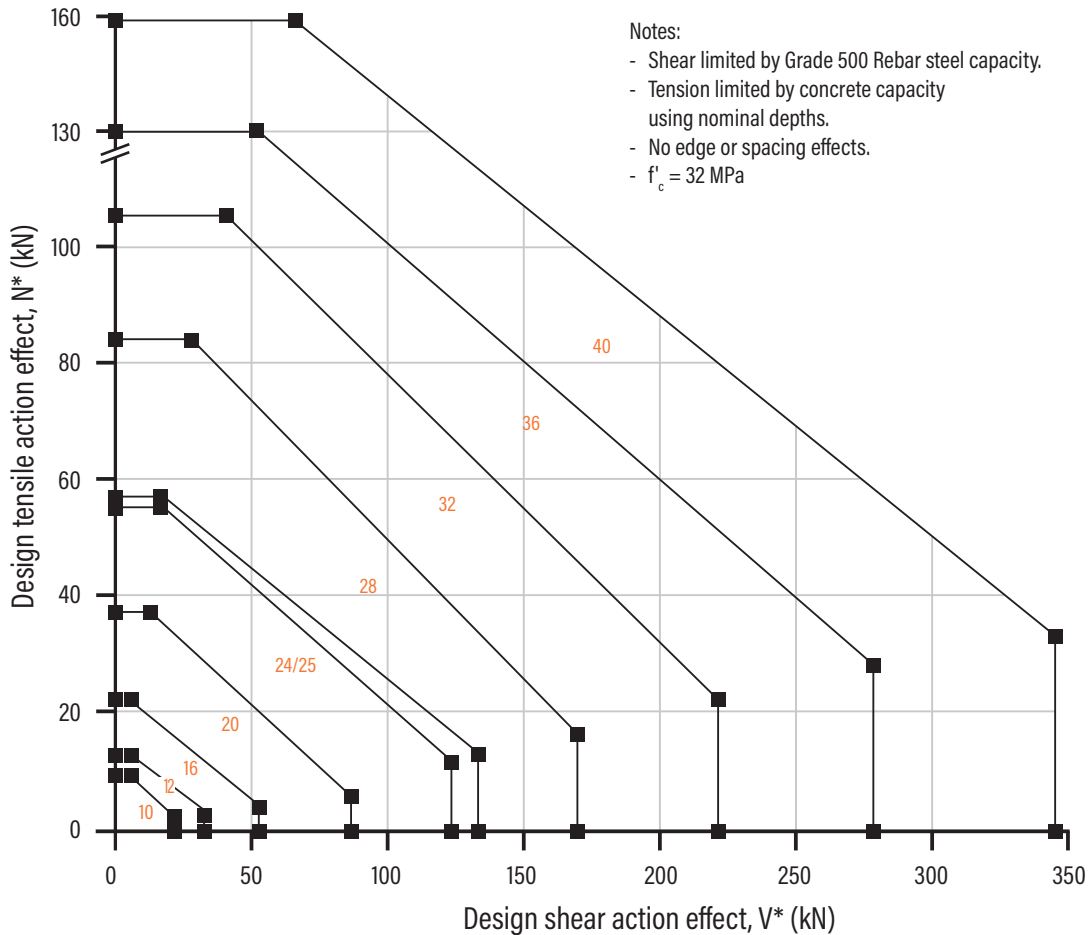

Table 1b Absolute minimum edge distance and anchor spacing values, e_m and a_m (mm)

Anchor size, d_b	10	12	16	20	24	25	28	32	36	40
e_m, a_m	30	36	48	60	72	75	84	96	108	120

Step 1c Calculate anchor effective depth, h (mm)

Refer to nominal recommended effective depths, h , listed in installation and performance details table on previous page.

Effective depth, h (mm)

Preferred $h = h_n$ otherwise

$h = L_e - t$,
 t = total thickness of material(s) being fixed

Substrate thickness, b_m (mm)

$b_m = \text{greater of: } 1.25 \times h,$
 $h + (2 \times d_h)$

Checkpoint

1 Anchor size determined, absolute minima compliance achieved, effective depth (h) calculated.

ChemSet™ 101 PLUS

STRENGTH LIMIT STATE DESIGN

Chemical Anchoring - Reinforcing Bar Anchorage

STEP 2 Verify concrete tensile capacity - per anchor

Table 2a Reduced characteristic ultimate concrete tensile capacity, ϕN_{uc} (kN), $\phi_c = 0.6$, $f'_c = 32$ MPa

Anchor size, d_b	10	12	16	20	24	25	28	32	36	40
Drilled Hole Dia, d_h (mm)	14	16	20	25	30	30	35	40	45	50
Effective Depth, h (mm)										
85	9.3									
90	9.8									
95	10.4									
100	10.9	13.1								
105	11.5	13.8								
110	12.0	14.5								
115	12.6	15.1								
125	13.7	16.4	21.9							
140	15.3	18.4	24.6							
150	16.4	19.7	26.3	32.9						
170		22.4	29.8	37.3						
180		23.7	31.6	39.5	47.4	49.4				
210			36.9	46.1	55.3	57.7	64.5			
240			42.2	52.7	63.3	65.9	73.8	84.3		
270				59.3	71.1	74.1	83.0	94.8	106.7	
300				65.9	79.0	82.4	92.2	105.4	118.6	131.7
320				70.2	84.3	87.9	98.4	112.4	126.5	140.5
330					86.9	90.6	101.4	115.9	130.4	144.9
360					94.8	98.8	110.7	126.5	142.3	158.1
420						115.3	129.1	147.6	166.0	184.5
460								161.7	181.8	202.0
500								175.7	197.6	219.6
550									217.4	241.6
600										263.5
625										274.5

Bold values are at ChemSet Anchor Stud nominal depths.

WET HOLES: Multiply $\phi N_{uc} \times 1$

All data relevant for Non-Cracked Concrete. For optimised performance data, please use Ramset iExpert Anchoring Software.

Table 2b Concrete compressive strength effect, tension, X_{nc}

f'_c (MPa)	20	25	32	40	50
X_{nc}	0.79	0.88	1.00	1.12	1.25

Table 2c Edge distance effect, tension, X_{ne}

Anchor size, d_b	10	12	16	20	24	25	28	32	36	40
Edge Distance, e (mm)										
30	0.83									
35	0.91	0.81								
40	1.00	0.88								
50		1.00	0.85							
65			1.00	0.87						
80				1.00	0.88	0.86				
95					1.00	0.97	0.89	0.82		
100						1.00	0.93	0.85		
110							1.00	0.90	0.83	
130								1.00	0.93	0.87
145									1.00	0.93
160										1.00

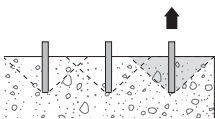

ChemSet™ 101 PLUS

STRENGTH LIMIT STATE DESIGN

Table 2d Anchor spacing effect, end of a row, tension, X_{nae}

For single anchor design, $X_{nae} = 1.0$

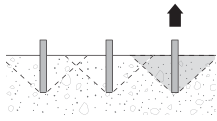

Anchor size, d_b	10	12	16	20	24	25	28	32	36	40
Anchor Spacing, a (mm)										
30	0.75									
35	0.79	0.74								
40	0.83	0.78								
50	0.92	0.85	0.76							
60	1.00	0.92	0.81	0.75						
75		1.00	0.89	0.81	0.76	0.75				
95			1.00	0.90	0.83	0.82	0.78			
120				1.00	0.92	0.90	0.86	0.81	0.78	0.75
140					1.00	0.97	0.92	0.86	0.82	0.79
150						1.00	0.95	0.89	0.85	0.81
170							1.00	0.94	0.89	0.85
195								1.00	0.95	0.91
220									1.00	0.96
240										1.00

Table 2e Anchor spacing effect, internal to a row, tension, X_{nai}

For single anchor design, $X_{nai} = 1.0$

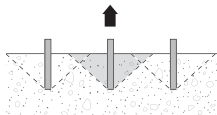

Anchor size, d_b	10	12	16	20	24	25	28	32	36	40
Anchor Spacing, a (mm)										
30	0.50									
35	0.58	0.49								
40	0.67	0.56								
50	0.83	0.69	0.52							
60	1.00	0.83	0.63	0.50						
75		1.00	0.78	0.63	0.52	0.50				
95			1.00	0.79	0.66	0.63	0.57	0.49		
120				1.00	0.83	0.80	0.71	0.63	0.56	0.50
150					1.00	1.00	0.89	0.78	0.69	0.63
170							1.00	0.89	0.79	0.71
195								1.00	0.90	0.81
215									1.00	0.90
240										1.00

Checkpoint

2

Design reduced ultimate concrete tensile capacity, ϕN_{urc}

$$\phi N_{urc} = \phi N_{uc} * X_{nc} * X_{ne} * (X_{nae} \text{ or } X_{nai})$$

STEP

3

Verify anchor tensile capacity - per anchor

Table 3a Reduced characteristic ultimate steel tensile capacity, ϕN_{us} (kN), $\phi_n = 0.8$

Anchor size, d_b	10	12	16	20	24	25	28	32	36	40
e_m, a_m	31.4	45.2	80.4	125.6	180.8	196.4	246.4	321.6	408.8	504.0

ChemSet™ 101 PLUS

STRENGTH LIMIT STATE DESIGN

Chemical Anchoring - Reinforcing Bar Anchorage

Checkpoint 3 Design reduced ultimate tensile capacity, ϕN_{ur}

$\phi N_{ur} = \text{minimum of } \phi N_{urc}, \phi N_{us}$

Check $N^* / \phi N_{ur} \leq 1$, if not satisfied return to step 1

Tensile performance conversion table

Performance Required	Concrete Tensile Performance		Steel Tensile Performance	
	Notation	Concrete Tension Capacity	Notation	Carbon Steel Tension Capacity
Strength Limit State	ϕN_{urc}	MULTIPLY $\phi N_{urc} \times 1.00$	ϕN_{us}	MULTIPLY $\phi N_{us} \times 1.00$
Working Load Limit	N_{ac}	MULTIPLY $\phi N_{urc} \times 0.55$	N_{as}	MULTIPLY $\phi N_{us} \times 0.56$
Cyclic Loading	N_{yc}	Refer to page 40 for suitable anchor	N_{ys}	Refer to page 40 for suitable anchor
Fire Resistance	$N_{Rk,c,fi,t}$	Refer to Fire Rated Anchors	$N_{Rk,s,fi,t}$	Refer to Fire Rated Anchors
Seismic	$N_{Rd,p,sis}^0$	Refer to Seismic Anchors	$N_{Rd,s,sis}$	Refer to Seismic Anchors

NOTE: Design Tensile Capacity is the minimum of Concrete Tension and Steel Tension Capacities

STEP 4 Verify concrete shear capacity - per anchor

Table 4a Reduced characteristic ultimate concrete edge shear capacity, ϕV_{uc} (kN), $\phi_q = 0.6$, $f_c = 32$ MPa

Anchor size, d_b	10	12	16	20	24	25	28	32	36	40
Edge Distance, e (mm)										
30	2.5									
35	3.2									
40	3.9	4.2								
50	5.5	5.9	6.5							
60	7.2	7.7	8.6	9.6						
75	10.1	10.8	12.0	13.4	14.7	14.7				
95	14.3	15.3	17.1	19.2	21.0	21.0	22.7			
120	20.4	21.8	24.3	27.2	29.8	29.8	32.2	34.4	36.5	38.5
200	43.8	46.8	52.4	58.6	64.1	64.1	69.3	74.1	78.6	82.8
300	80.5	86.1	96.2	107.6	117.8	117.8	127.3	136.1	144.3	152.1
400	123.9	132.5	148.1	165.6	181.4	181.4	196.0	209.5	222.2	234.2
500	173.2	185.2	207.0	231.5	253.6	253.6	273.9	292.8	310.6	327.4
600	227.7	243.4	272.2	304.3	333.3	333.3	360.0	384.9	408.2	430.3

Note: Effective depth, h must be $\geq 6 \times$ drilled hole diameter, d_h for anchor to achieve tabled shear capacities.

Table 4b Concrete compressive strength effect, concrete edge shear, X_{vc}

f_c (MPa)	20	25	32	40	50
X_{vc}	0.79	0.88	1.00	1.12	1.25

Table 4c Load direction effect, concrete edge shear, X_{vd}

Angle, α°	0	10	20	30	40	50	60	70	80	90-180
X_{vd}	1.00	1.04	1.16	1.32	1.50	1.66	1.80	1.91	1.98	2.00

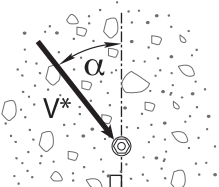

Load direction effect, conc. edge shear, X_{vd}

ChemSet™ 101 PLUS

STRENGTH LIMIT STATE DESIGN

Table 4d Anchor spacing effect, concrete edge shear, X_{va}

Note: For single anchor designs, $X_{va} = 1.0$

Edge distance, e (mm)	25	30	35	50	60	75	125	200	300	400	500	600
Anchor spacing, a (mm)												
25	0.70	0.67	0.64	0.60	0.58	0.57	0.54					
30	0.74	0.70	0.67	0.62	0.60	0.58	0.55	0.53				
35	0.78	0.73	0.70	0.64	0.62	0.59	0.56	0.54	0.52			
50	0.90	0.83	0.79	0.70	0.67	0.63	0.58	0.55	0.53	0.53		
60	0.98	0.90	0.84	0.74	0.70	0.66	0.60	0.56	0.54	0.53	0.52	
75	1.00	1.00	0.93	0.80	0.75	0.70	0.62	0.58	0.55	0.54	0.53	0.53
150			1.00	1.00	1.00	0.90	0.74	0.65	0.60	0.58	0.56	0.55
200						1.00	0.82	0.70	0.63	0.60	0.58	0.57
300							0.98	0.80	0.70	0.65	0.62	0.60
400							1.00	0.90	0.77	0.70	0.66	0.63
500								1.00	0.83	0.75	0.70	0.67
625									0.92	0.81	0.75	0.71
750									1.00	0.88	0.80	0.75
875										0.94	0.85	0.79
1000										1.00	0.90	0.83
1250											1.00	0.92
1500												1.00

Table 4e Multiple anchors effect, concrete edge shear, X_{vn}

Note: For single anchor designs, $X_{vn} = 1.0$

Anchor spacing / Edge distance, a / e	0.20	0.40	0.60	0.80	1.00	1.20	1.40	1.60	1.80	2.00	2.25	2.50
Number of anchors, n												
2	1.00	1.00	1.00	1.00	1.00	1.00	1.00	1.00	1.00	1.00	1.00	1.00
3	0.72	0.76	0.80	0.83	0.86	0.88	0.91	0.93	0.95	0.96	0.98	1.00
4	0.57	0.64	0.69	0.74	0.79	0.82	0.86	0.89	0.92	0.94	0.97	1.00
5	0.49	0.57	0.63	0.69	0.74	0.79	0.83	0.87	0.90	0.93	0.97	1.00
6	0.43	0.52	0.59	0.66	0.71	0.77	0.81	0.85	0.89	0.93	0.96	1.00
7	0.39	0.48	0.56	0.63	0.69	0.75	0.80	0.84	0.88	0.92	0.96	1.00
8	0.36	0.46	0.54	0.61	0.68	0.74	0.79	0.84	0.88	0.92	0.96	1.00
9	0.34	0.44	0.52	0.60	0.67	0.73	0.78	0.83	0.87	0.91	0.96	1.00
10	0.32	0.42	0.51	0.59	0.66	0.72	0.77	0.82	0.87	0.91	0.96	1.00
15	0.26	0.37	0.47	0.55	0.63	0.70	0.76	0.81	0.86	0.90	0.95	1.00
20	0.23	0.35	0.45	0.54	0.61	0.68	0.75	0.80	0.85	0.90	0.95	1.00

Table 4f Anchor at a corner effect, concrete edge shear, X_{vs}

Note: For $e_1/e_2 > 1.25$, $X_{vs} = 1.0$

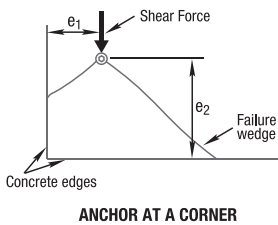

Edge distance, e_2 (mm)	25	30	35	50	60	75	125	200	300	400	600	900
Edge distance, e_1 (mm)												
25	0.86	0.77	0.70	0.58	0.53	0.49	0.41	0.37	0.35	0.34	0.32	0.32
30	0.97	0.86	0.78	0.64	0.58	0.52	0.43	0.38	0.36	0.34	0.33	0.32
35	1.00	0.95	0.86	0.69	0.63	0.56	0.46	0.40	0.37	0.35	0.33	0.32
50	1.00	1.00	1.00	0.86	0.77	0.67	0.52	0.44	0.39	0.37	0.35	0.33
60	1.00	1.00	1.00	0.97	0.86	0.75	0.57	0.47	0.41	0.38	0.36	0.34
75	1.00	1.00	1.00	1.00	1.00	0.86	0.64	0.51	0.44	0.41	0.37	0.35
125	1.00	1.00	1.00	1.00	1.00	1.00	0.86	0.65	0.53	0.48	0.42	0.38
200	1.00	1.00	1.00	1.00	1.00	1.00	1.00	0.86	0.67	0.58	0.49	0.42
300	1.00	1.00	1.00	1.00	1.00	1.00	1.00	1.00	0.86	0.72	0.58	0.49
400	1.00	1.00	1.00	1.00	1.00	1.00	1.00	1.00	1.00	0.86	0.67	0.55
500	1.00	1.00	1.00	1.00	1.00	1.00	1.00	1.00	1.00	1.00	0.77	0.61
600	1.00	1.00	1.00	1.00	1.00	1.00	1.00	1.00	1.00	1.00	0.86	0.67
900	1.00	1.00	1.00	1.00	1.00	1.00	1.00	1.00	1.00	1.00	1.00	0.86

ChemSet™ 101 PLUS

STRENGTH LIMIT STATE DESIGN

Chemical Anchoring - Reinforcing Bar Anchorage

Checkpoint 4

Design reduced ultimate concrete edge shear capacity, ϕV_{urc}

$$\phi V_{urc} = \phi V_{uc} * X_{vc} * X_{vd} * X_{va} * X_{vn} * X_{vs}$$

STEP 5

Verify anchor shear capacity - per anchor

Table 5a Reduced characteristic ultimate steel shear capacity, ϕV_{us} (kN), $\phi_v = 0.8$

Anchor size, d_b	10	12	16	20	24	25	28	32	36	40
Grade 500 Rebar	21.4	30.8	54.8	85.7	123.3	133.9	168.0	219.3	278.3	343.7

Checkpoint 5

Design reduced ultimate shear capacity, ϕV_{ur}

$$\phi V_{ur} = \text{minimum of } \phi V_{urc}, \phi V_{us}$$

Check $V^* / \phi V_{ur} \leq 1$,

if not satisfied return to step 1

Shear performance conversion table

Performance Required	Concrete Shear Performance		Steel Shear Performance	
	Notation	Concrete Shear Capacity	Notation	Carbon Steel Shear Capacity
Strength Limit State	ϕV_{uc}	MULTIPLY $\phi V_{uc} \times 1.00$	ϕV_{us}	MULTIPLY $\phi V_{us} \times 1.00$
Working Load Limit	V_{ac}	MULTIPLY $\phi V_{uc} \times 0.55$	V_{as}	MULTIPLY $\phi V_{us} \times 0.45$
Cyclic Loading	V_{yc}	Refer to page 40 for suitable anchor	V_{ys}	Refer to page 40 for suitable anchor
Fire Resistance	$V_{Rk,c,fi,t}$	Refer to Fire Rated Anchors	$V_{Rk,s,fi,t}$	Refer to Fire Rated Anchors
Seismic	$V_{Rd,c,sis}^0$	Refer to Seismic Anchors	$V_{Rd,s,sis}^0$	Refer to Seismic Anchors

NOTE: Design Shear Capacity is the minimum of Concrete Shear and Steel Shear Capacities

STEP 6

Combined loading and specification

Checkpoint 6

Check

$$N^* / \phi N_{ur} + V^* / \phi V_{ur} \leq 1.2,$$

if not satisfied return to step 1

Specify - Reinforcing Bar Anchorage

Ramset ChemSet 101 PLUS with (Anchor Size) grade 500 Rebar.
 Drilled hole depth to be (h) mm.

Example

Ramset ChemSet 101 PLUS with N20 grade 500 Rebar
 Drilled hole depth to be 160 mm.
 To be installed in accordance with Ramset Installation Instructions.

Introduction

[Back to index](#)

CHEMICAL ANCHORING - REINFORCING BAR TO AS3600 & AS5216

Chemical Anchoring - Rebar to AS3600 & AS5216



Chemical Anchoring Reinforcing Bar to AS3600 & AS5216

AS3600 - 2018 Section 13 covers development of stress in cast-in reinforcement.

In order to obtain full steel yield stress in a reinforcing bar it must be embedded in concrete to a length where the bond stress and steel stress are balanced and the bar does not displace within the concrete. The embedded length of bar is termed the Development Length ($L_{sy,t}$). Furthermore, in accordance with AS5216:2021 Appendix D, the Chemical Adhesive when used with post-installed reinforcing bar requires a pre-qualification document demonstrating testing in accordance with EAD 330087

Stress Development in Post-installed Adhesive Bonded Reinforcement in Solid Concrete

Polymer adhesives like epoxy, generally bond significantly better to steel reinforcement than concrete to steel reinforcement. Consequently the development lengths of reinforcing bars bonded in concrete with adhesives are often significantly shorter than development lengths of cast-in bars. As with cast-in bars, loads on adhesive bonded reinforcing bars are transmitted to and cause stress in the surrounding concrete.

The stress around a single reinforcing bar in tension remote from a concrete edge is given by:

$$\sigma_b = \frac{A_b \cdot f_{sy}}{L_{sy,t} \cdot \pi \cdot d_b} \dots \text{Equation 1}$$

- σ_b = Bond Stress to the Concrete (MPa)
- A_b = Cross-sectional Area of the Bar (mm²)
- f_{sy} = Steel Yield Stress (MPa)
- $L_{sy,t}$ = Minimum embedment length of rebar to develop steel yield stress (mm)
- π = pi
- d_b = nominal bar diameter (mm)

In the case where spacing and edge distances are remote, there is enough concrete cover to the bar and adhesive to dissipate the stresses in the concrete and avoid splitting failures. However, the situation changes when another bar or bars is introduced

and or the concrete edge is no longer remote. Close bar spacing or insufficient concrete cover may result in splitting failures such as those illustrated in figure 1.

From equation 1 above, stress (σ_b) in the concrete surrounding the bar decreases with increasing embedded length ($L_{sy,t}$). See graph below of bond stress developed in concrete when steel yield stress is applied to a reinforcing bar as a function of embedded length.

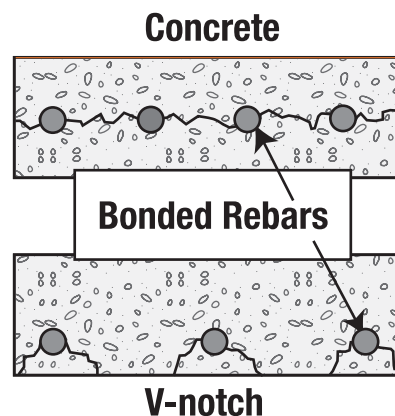
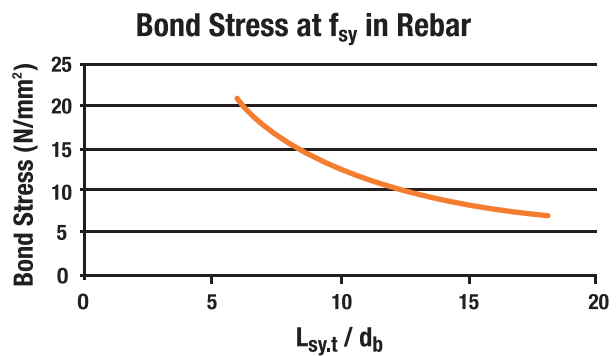

Figure 1.

Introduction

CHEMICAL ANCHORING - REINFORCING BAR TO AS3600 & AS5216

Therefore where there is shallow cover or close bar spacing, it is necessary to apply the splitting factor k_1, k_2 & k_3 listed in Section 13 of AS3600 - 2018. The splitting factors influence the development length to ensure there is sufficient embedment to reduce stress in concrete and prevent splitting failures.

Development lengths calculated from bond strength alone should NOT be used for bar anchorages designed to comply with AS3600 - 2018 as concrete splitting is not accounted for.

If splitting factors from AS3600 are not applied to development lengths of post-installed reinforcing bars in structural concrete elements, there may be a significant reduction in safety resulting in concrete failure and collapse due to concrete splitting. Concrete splitting is a function of edge distance and spacing and is independent of adhesive bond strength.

Derivation of Development Length for Adhesive Bonded Bars

Development lengths are predicted from bond stress, determined from pull out tests, according to equation 2. The predicted lengths are verified according to the current revision of AS/NZS 4671, Appendix C4, where a load equal to N_{sy} is applied and a displacement of the bar less than 0.2 mm recorded.

$$L_{sy,t} = \frac{A_b \cdot f_{sy}}{\sigma_b \cdot \pi \cdot d_b} \dots \text{Equation 2}$$

The development length is a function of adhesive bond stress so a limit state factor of 0.6 is applied:

$$\frac{L_{sy,t}}{\emptyset} = \frac{A_b \cdot f_{sy}}{0.6 \cdot \sigma_b \cdot \pi \cdot d_b} \dots \text{Equation 3}$$

Effectively the limit state factor increases development length by 67%.

The development length tables in "Design Case 1" in the following section are calculated using Equation 3. This relationship applies to a single bar remote from an edge and does not account for concrete splitting affects.

For designs where there are multiple parallel reinforcing bars in structural elements such as walls, floors, beams and columns, concrete splitting factors from section 13.1 of AS3600 should be used. Concrete splitting is independent of adhesive bond strength and should be applied to all adhesive bonded bars where the design is intended to comply with AS3600.

AS5216 - 2021 Appendix D covers development length of post-installed reinforcing bar

AS5216:2021 Appendix D Clause D.4.2 states 'The embedment length of post-installed reinforcing bars to develop characteristic yield strength of a reinforcing bar shall not be less than the development length obtained in accordance with AS3600.'

Therefore, the basic development length of deformed bar according to AS3600-2018 Clause 13.1.2.2 can be calculated as follows,

$$L_{sy,t} = \frac{0.5 \cdot k_1 \cdot k_3 \cdot f_{sy} \cdot d_b}{k_2 \sqrt{(f'c)}} \geq 0.058 \cdot f_{sy} \cdot k_1 \cdot d_b \dots \text{Equation 4}$$

Furthermore, where the full yield strength is not required, the development length can be calculated in accordance with AS3600-2018 Clause 13.1.2.4 which prohibits development lengths less than 12db as follows,

$$L_{st} = L_{sy,t} \cdot \frac{\sigma_{st}}{f_{sy}} \geq 12d_b \dots \text{Equation 5}$$

where σ_{st} = Required tensile stress

The development length tables in "Design Case 2, 3 and 4" in the following section are calculated using equation 4.

k_1 = 1.0 for adhesive bonded bars. In section 13.1 of AS3600 - 2018 k_1 = 1.3 for all horizontal bars with > 300 mm of concrete below them. According to Warner et al³ (pg391), a zone of weak, air and water rich concrete forms on the lower surface of 'top' bars, which reduces the bond characteristics of bars in this position. Since the weakened zone of concrete is specific to cast-in bars it is not relevant to bonded bars and therefore k_1 = 1 in all cases.

k_2 is the direction function of the bar diameter (d_b).

The value of k_3 is influenced by the anchor spacing (a), edge distance/cover (e) and the bar diameter (d_b).

Edge Distance and Spacing

Edge distance and spacing of reinforcing bars are independent of adhesive bond strength. They are related to the stress transferred from the bars under tension, through the adhesive and into the concrete. As shown in equation 1 stress transferred to concrete by bars under tension is reduced by increasing embedded length. Hence AS3600 applies the splitting factors, k_1, k_2 and k_3 to influence the development length.

AS3600 allows for various depths of concrete cover to bars depending on environmental and other circumstances. The designer must refer to AS3600 to determine required cover.

In the following tables a minimum cover of 30 mm or $2 \times d_b$ ($2.5 \times d_b$ edge distance) is adopted.

References

1. AS3600 - 2018 Concrete Structures, Standards Australia
2. AS/NZS4671 - 2001 Steel Reinforcing Materials, Standards Australia
3. Warner, R.F. Rangan B.V. Hall A.S. Faulkes K.A. 1998, 'Concrete Structures', Addison Wesley Longman Australia
4. AS5216 - 2021 Design of post-installed and Cast-in fastenings in concrete.

Design Process

[Back to index](#)

CHEMICAL ANCHORING - REINFORCING BAR TO AS3600 & AS5216

This information is intended for use by qualified engineers or other suitably skilled persons. It is the designer's responsibility to ensure compliance with the relevant standards, codes of practice, building regulations, workplace regulations and statutes as applicable.

This section must be used in conjunction with AS3600 - 2018 and is intended to assist in design of reinforcing bar connections where they are post-installed using ChemSet™ Anchoring adhesives rather than being cast into the concrete.

For selection of the appropriate reinforcing bar diameter, reference should be made to the manufacturer's design tables and AS3600 - 2018.

The document provides the steel yield development length $L_{sy,lr}$ required by AS3600 - 2018, clause 13.1.2.2 for Grade 500 reinforcing bars post-installed with ChemSet™ Anchoring adhesives into concrete.

The design process begins with the Designer choosing the relevant Design Case:

The Design Cases are:

1. Development Length of single bar remote from an edge
2. Development Length of multiple bars in concrete elements.
(Large clear anchor spacing)
3. Development Length of multiple bars in concrete elements.
(Medium clear anchor spacing)
4. Development Length of multiple bars in concrete elements.
(Minimum clear anchor spacing)

Having obtained the nominal development length for the design case, adjustment is made for the influence of concrete compressive strength to yield the value $L_{sy,t}$.

In the case where there is not sufficient depth of concrete for the reinforcing bar to be installed to $L_{sy,t}$, or the stress area of tensile steel exceeds design requirements, the stress (σ_{st}) less than the yield strength (f_{sy}) developed in the bar is provided for a variety of lengths (L_{st}), per clause 13.1.2.4 of AS3600 - 2018. Having obtained the stress developed in the bar for a nominated installed length, adjustment is made to the developed stress for the influence of concrete compressive strength.

Design Process

WORKED EXAMPLE

DESIGN EXAMPLE 1

Using the AS1170 family of Australian Standards, the design action effect causing tension in reinforcing bars is calculated to be:

$$N^* = 637 \text{ kN/m. run}$$

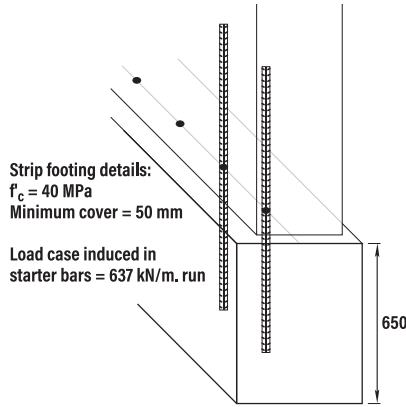

Consider design of Grade 500 reinforcement bar, fully developed.

To satisfy Strength Limit State Design criteria,

$$N^* \leq \phi f_{sy} * A_b$$

therefore, $637 * 10^3 \text{ N} \leq 0.8 * 500 * A_b$
 transposing gives us, $A_b \geq 1593 \text{ mm}^2$

From reinforcement bar manufacturers tables,

Rebar Size 24 @ 275 mm. centres provides 1636 mm²/m. run

Which satisfies our steel sectional requirement.

As the project requires a post-installed solution, consider the use of ChemSet™ Reo 502™ Plus, Chemset™ 801 Xtrem™ XC² or EPCON™ C8 Xtrem™

Design is a wall with multiple longitudinal bars at 275 mm centres so Design Case 2 applies.

From Table 2, $L_{sy,t(nom)} = 700 \text{ mm}$

From Table 2a, $X_{nc} = 0.89 @ f_c = 40 \text{ MPa}$

The tensile development length for Rebar Size 24 using ChemSet™ Reo 502™ Plus, Chemset™ 801 Xtrem™ XC² or EPCON™ C8 Xtrem™ is:

$$L_{sy,t} = L_{sy,t(nom)} * X_{nc}$$

$$= 700 * 0.89$$

$$= 623 \text{ mm}$$

Specify

N24 @ 275 mm. centres post-installed using Ramset™ ChemSet™ Reo 502™ Plus, Chemset™ 801 Xtrem™ XC₂ or EPCON™ C8 Xtrem™ @ 623 mm. deep

DESIGN EXAMPLE 2

Consider the previous case; however the footing depth is 590 mm. Given minimum cover is 50 mm, the maximum bar length is 540 mm.

Use stress developed in the bar to determine the centre spacings required to achieve the design load case at shorter bar lengths.

From Table 2, Using $L_{st} = 540 \text{ mm}$
 Rebar Size = 24

gives, $\sigma_{st(nom)} = 386 \text{ MPa}$
 From Table 2b, $X_{nc} = 1.12 @ 40 \text{ MPa}$

The stress developed in the bar at this depth is,

$$\sigma_{st} = \sigma_{st(nom)} * X_{nc}$$

$$= 430 \text{ MPa}$$

hence, $N^* \leq \phi \sigma_{st} * A_b$
 therefore, $637 * 10^3 \text{ N} \leq 0.8 * 430 * A_b$
 transposing gives us, $A_b \geq 1852 \text{ mm}^2$

From reinforcement bar manufacturers tables,

Rebar Size 24 @ 250 mm. centres provides 1850 mm²/m. run

Which satisfies our steel sectional requirement.

Specify

N24 @ 250 mm. centres post-installed using Ramset™ ChemSet™ Reo 502™ Plus, Chemset™ 801 Xtrem™ XC² or EPCON™ C8 Xtrem™ @ 540 mm. deep

Reinforcing Bar

ENGINEERING PROPERTIES

[Back to index](#)

Grade 500 Reinforcing Bar

ENGINEERING PROPERTIES

Typical Engineering Properties of Grade 500 Reinforcing Bar

Rebar size	10	12	16	20	24	25	28	32	36	40
Drilled hole dia., d_h (mm)	14*	16**	20	25	30	30	35	40	45	50
Stress area, A_b (mm ²)	78.5	113	201	314	452	491	616	804	1020	1260
Yield stress, f_{sy} (MPa)	500	500	500	500	500	500	500	500	500	500
Tensile steel yield capacity N_{sy} , (kN)	39.3	56.5	100.5	157.0	226.0	245.5	308.0	402.0	510.0	630.0

For further information refer to reinforcing bar manufacturer's published information and current revision of **AS/NZS 4671**.

*Note: For EPCON C8 Xtrem with 10mm Rebar Size, drill hole diameter $d_h = 12$ mm

**Note: For EPCON C8 Xtrem with 12mm Rebar Size, drill hole diameter $d_h = 15$ mm

ChemSet™ Reo 502™ PLUS

CHEMICAL INJECTION - NON-CRACKED & CRACKED CONCRETE

Back to index

AVAILABLE IN AUSTRALIA ONLY

(New Zealand refer to EPCON™ C6 PLUS range)

GENERAL INFORMATION

Performance Related



Installation Related



Product

ChemSet™ Reo 502™ PLUS is a heavy duty pure Epoxy for anchoring threaded studs and reinforcing bar into cracked and uncracked concrete.

Compliance

Design according to AS5216:2021 Appendix D and AS3600-2018 clause 13.1.2.2 steel yield development length

- European Technical Assessment - tested to EAD 330087

Benefits, Advantages and Features

- 100 year working life

Greater productivity:

- Anchors in dry, damp, wet or flooded holes
- Easy dispensing even in cold weather

Greater security:

- Strong bond
- Rated for sustained loading

Versatile:

- Anchors in carbide drilled and diamond drilled holes
- Cold and temperate climates

Greater safety:

- Low odour
- VOC Compliant



Principal Applications

- Threaded Studs
- Starter Bars
- Threaded Inserts
- Over-head installation
- Steel Columns
- Hand Rails
- Road Stitching

Recommended Installation Temperatures

	Minimum	Maximum
Substrate	5°C	40°C
Adhesive	10°C	40°C

Service Temperature Limits

-40°C to 70°C

Setting Times Reo 502™ Plus

Temperature of base material	Cartridge Temperature	Gel Time	Curing time in dry and wet concrete
5°C	Minimum 10°C	300 min	24 h
10°C	10°C	150 min	18 h
15°C	15°C	40 min	12 h
20°C	20°C	25 min	8 h
25°C	25°C	18 min	6 h
30°C	30°C	12 min	4 h
40°C	40°C	6 min	2 h

Note: Cartridge temperature minimum +10°C

Installation

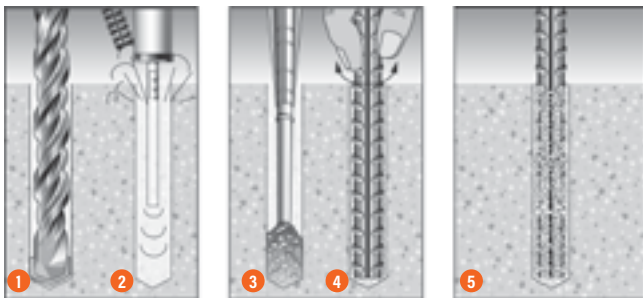

1. Drill recommended diameter and depth hole.
2. **Important:** Use **Ramset™** Dustless Drilling System to ensure holes are clean. Alternatively, clean dust and debris from hole with stiff wire or nylon brush and blower in the following sequence: blow x 2, brush x 2, blow x 2, brush x 2, blow x 2.
3. Dispense adhesive to waste until colour is uniform light grey (2-3 trigger pulls). Insert mixing nozzle to bottom of hole. Fill hole to 3/4 the hole depth slowly, ensuring no air pockets form.
4. Insert **Ramset™** ChemSet™ Anchor Stud/rebar to bottom of hole while turning.
5. Allow ChemSet™ Reo 502™ PLUS to cure as per setting times.

DESCRIPTION AND PART NUMBERS

Description	Cartridge Size	Part No.	Working Time at 20°C	Cure Time at 20°C
ChemSet Reo 502 PLUS	600 ml	RE0502P600	25 minutes	12 hours

ChemSet™ 801 Xtrem™ XC²

CHEMICAL INJECTION - NON-CRACKED & CRACKED CONCRETE

[Back to index](#)

GENERAL INFORMATION

Performance Related	Installation Related

Product

ChemSet™ 801 Xtrem™ XC² is a heavy duty Vinylester for anchoring threaded studs and reinforcing bar into cracked and uncracked concrete.



Compliance

Design according to AS5216:2021 Appendix D and AS3600-2018 clause 13.1.2.2 steel yield development length

- European Technical Assessment - tested to EAD 330087

Benefits, Advantages and Features

- 100 year working life
- Flooded Holes
- Fire rated
- Greater productivity:**
 - Easy dispensing even in cold weather
 - Apply torque in 2 hours @ 20°C
- Greater security:**
 - Strong bond
 - Rated for sustained loading
- Versatile:**
 - Earthquake, Fire & Flooded Conditions
 - Cold and temperate climates
- Greater safety:**
 - Low odour
 - VOC Compliant
 - Suitable for contact with drinking water

Made in Australia



Principal Applications

- Threaded Studs
- Starter Bars
- Threaded Inserts
- Over-head installation
- Steel Columns
- Hand Rails
- Road Stitching

Recommended Installation Temperatures

	Minimum	Maximum
Substrate	5°C	40°C
Adhesive	5°C	40°C

Service Temperature Limits

-40°C to 80°C

Setting Times 801 Xtrem™ XC²

Temperature of base material	Gel Time	Curing time in dry concrete	Curing time in wet concrete
+5°C	60 min	240 min	480 min
6°C - 10°C	40 min	180 min	360 min
11°C - 20°C	15 min	120 min	240 min
21°C - 30°C	8 min	90 min	180 min
31°C - 40°C	4 min	60 min	120 min

Note: Cartridge temperature minimum +5°C

Note:

* Diamond Core drilling only applicable for 50 years working life.

Installation

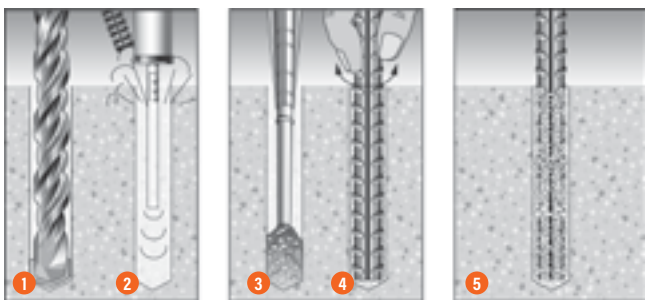

1. Drill recommended diameter and depth hole.
2. **Important:** Use Ramset™ Dustless Drilling System to ensure holes are clean. Alternatively, clean dust and debris from hole with stiff wire or nylon brush and blower in the following sequence: blow x 2, brush x 2, blow x 2.
3. Dispense adhesive to waste until colour is uniform light grey (2-3 trigger pulls). Insert mixing nozzle to bottom of hole. Fill hole to 3/4 the hole depth slowly, ensuring no air pockets form.
4. Insert Ramset™ ChemSet™ Anchor Stud/rebar to bottom of hole while turning.
5. Allow ChemSet™ 801 Xtrem™ XC² to cure as per setting times.

Chemical Anchoring - Rebar to AS3600 & AS5216

EPCON™ C8 Xtrem™

CHEMICAL INJECTION - NON-CRACKED & CRACKED CONCRETE

[Back to index](#)

GENERAL INFORMATION

Performance Related	Installation Related

Product
 EPCON™ C8 Xtrem™ is a High Performance Pure Epoxy Anchoring adhesive for use in Cracked and Non-Cracked concrete. For structures subject to external exposure, permanently damp or aggressive conditions.



Compliance
 Design according to AS5216:2021 Appendix D and AS3600-2018 clause 13.1.2.2 steel yield development length
 • European Technical Assessment - tested to EAD 330087



Benefits, Advantages and Features

- 100 year working life
- Approved for flooded holes
- Approved for floor, wall & overhead applications
- Data for 100 years sustained loading

Greater productivity:

- Anchors in dry, damp, wet or flooded holes
- No weather delays
- Fast, easy dispensing with high flow mixer

Greater security:

- Highest performance in cracked concrete

Versatile

- Anchors all stud & bar diameters in all directions
- Oversized holes
- Anchors in carbide drilled and diamond cored holes
- For tropical and cold weather conditions

Greater safety:

- Low odour

Fire Rated : Refer Fire rated anchoring section

Principal Applications

- Anchoring into cracked & non cracked concrete
- Road barrier hold down bolts
- Bridge refurbishment
- Road & Rail tunnel construction
- Reinforcing bar from 10 to 32mm
- Starter Bars
- Threaded Studs from M8 to M30
- Threaded Stud material: Zn, A4 316, HCR steels
- Threaded Stud material: 5.8, 8.8, 10.9 grade

Recommended Installation Temperatures

	Minimum	Maximum
Substrate	5°C	40°C
Adhesive	5°C	40°C

Load should not be applied to anchor until the chemical has sufficiently cured as specified.

Service Temperature Limits

-40°C to 80°C

Setting Times EPCON™ C8 Xtrem™

Temperature of base material	Gel Time	Curing time in dry concrete	Curing time in wet concrete
5°C - 9°C	20 min	30 h	60 h
10°C - 19°C	14 min	23 h	46 h
20°C - 24°C	11 min	16 h	32 h
25°C - 29°C	8 min	12 h	24 h
30°C - 39°C	5 min	8 h	16 h
40°C	5 min	6 h	12 h

Note
 *Performance of cored & oversized holes was not included in the ETAG test program and therefore is based on testing conducted at Ramset™ Product Engineering Laboratory.

Installation

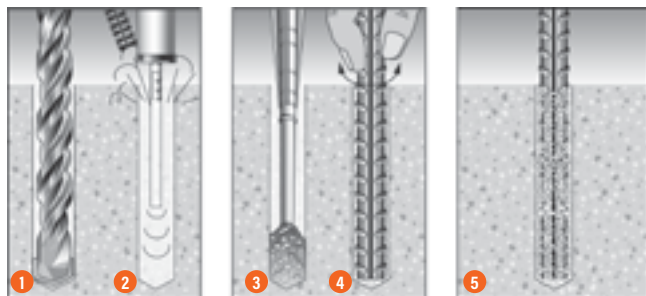

1. Drill recommended diameter and depth hole.
2. **Important:** Use **Ramset™** Dustless Drilling System to ensure holes are clean. Alternatively, clean dust and debris from hole with stiff wire or nylon brush and blower in the following sequence: blow x 2, brush x 2, blow x 2.
3. Dispense adhesive to waste until colour is uniform light grey (2-3 trigger pulls). Insert mixing nozzle to bottom of hole. Fill hole to 3/4 the hole depth slowly, ensuring no air pockets form.
4. Insert rebar to bottom of hole while turning.
5. Allow EPCON™ C8 Xtrem™ to cure as per setting times.

Chemical Anchoring - Rebar to AS3600 & AS5216

Chemset Reo 502™ Plus, Chemset 801 Xtrem™ XC² or EPCON™ C8 Xtrem™ STRENGTH LIMIT STATE DESIGN

[Back to index](#)

Strength Limit State Design

Design Case 1 For Single Bar Remote from an Edge ($e > 4 d_b$)

For designs intended to comply with AS5216-2021 and AS3600-2018, refer to Design cases 2, 3 and 4

Concrete Splitting Factors

k_1	1.0
k_2	1.0
k_3	1.0

Table 1 Nominal steel yield development length $L_{sy,t(nom)}$ of Grade 500 reinforcing bar in tension post-installed in 32 MPa concrete with ChemSet™ Reo 502™ Plus, Chemset™ 801 Xtrem™ XC² or EPCON™ C8 Xtrem™

Rebar size	10*	12	16	20	24	25	28	32	36*	40*
Minimum Cover, e (mm)	40	48	64	80	96	100	112	128	144	160
Min. Clear Spacing, a (mm)	NR	NR	NR	NR	NR	NR	NR	NR	NR	NR
Adhesive reduced ultimate tensile bond capacity ϕN_{ub} (kN), $\phi_c = 0.6$	39.3	56.5	100.5	157.0	226.0	245.5	308.0	402.0	510.0	630.0
Nominal development length of bar in tension, $L_{sy,t(nom)}$	105	140	205	265	335	360	400	470	540	615
Effective length, L_{st} (mm)	Stress developed in steel, $\sigma_{st(nom)}$ (MPa)									
50	238									
60	286									
70	333	250								
80	381	286								
90	429	321								
100	476	357	244							
105	500	375	256							
120		429	293	226						
140		500	341	264	209					
160			390	302	239	222				
190			463	358	284	264	238			
205			500	387	306	285	256			
220				415	328	306	275	234		
230				434	343	319	288	245	213	
265				500	396	368	331	282	245	
300					448	417	375	319	278	
335					500	465	419	356	310	272
360						500	450	383	333	293
380							475	404	352	309
400							500	426	370	325
430								457	398	350
450								479	417	366
470								500	435	382
540									500	439
615										500

500 Denotes adhesive tensile bond stress at Grade 500 steel yield development length, $L_{sy,t}$. Interpolation permitted. Do not extrapolate.

*Note: 10, 36 & 40 mm Reinforcing bar diameter data only applies to ChemSet™ Reo 502™ Plus and EPCON™ C8 Xtrem™

Chemical Anchoring - Rebar to AS3600 & AS5216

Chemset Reo 502™ Plus, Chemset 801 Xtrem™ XC² or EPCON™ C8 Xtrem™ STRENGTH LIMIT STATE DESIGN

Checkpoint **1a**

Table 1a Concrete compressive strength effect on development length, tension, X_{nc}

f'_c (MPa)	20	25	32	40	50
X_{nc}	1.26	1.13	1.00	0.89	0.80

Design reinforcing bar steel development length, $L_{sy,t}$ (mm)

$$L_{sy,t} = L_{sy,t} (nom) * X_{nc}$$

If there is insufficient concrete depth to install bar to $L_{sy,t}$
go to Checkpoint 1b

Note: Effect of water in hole, multiply $L_{sy,t}$ by 1.4.

Checkpoint **1b**

Table 1b Concrete compressive strength effect on steel stress, tension, X_{nc}

f'_c (MPa)	20	25	32	40	50
X_{nc}	0.79	0.88	1.00	1.12	1.25

Design tensile steel stress, σ_{st} (MPa)

$$\sigma_{st} = \sigma_{st} (nom) * X_{nc}$$

Note: Effect of water in hole, multiply σ_{st} by 0.7.

Chemset Reo 502™ Plus, Chemset 801 Xtrem™ XC² or EPCON™ C8 Xtrem™ STRENGTH LIMIT STATE DESIGN

Chemical Anchoring - Rebar to AS3600 & AS5216

Strength Limit State Design

Design Case **2** Multiple Bars in Concrete Elements (Large clear anchor spacing)

Steel yield development length, $L_{sy,t}$ (AS5216-2021 Appendix D and AS3600 - 2018, clause 13.1.2.2)

Table 2 Nominal steel yield development length $L_{sy,t(nom)}$ of Grade 500 reinforcing bar in tension post-installed in 32 MPa concrete with ChemSet™ Reo 502™ Plus, Chemset™ 801 Xtrem™ XC² or EPCON™ C8 Xtrem™

Rebar size	10*	12	16	20	24	25	28	32	36*	40*
Concrete Splitting Factor, k_1	1.0	1.0	1.0	1.0	1.0	1.0	1.0	1.0	1.0	1.0
Concrete Splitting Factor, k_2	1.2	1.2	1.2	1.1	1.1	1.1	1.0	1.0	1.0	0.9
Concrete Splitting Factor, k_3	0.7	0.7	0.7	0.7	0.7	0.7	0.7	0.7	0.7	0.7
Minimum Cover, e (mm)	40	40	45	60	75	75	95	110	130	150
Min. Clear Spacing, a (mm)	80	80	90	125	150	150	190	220	260	300
Adhesive reduced ultimate tensile bond capacity ϕN_{ub} , (kN), $\phi_c = 0.6$	39.3	56.5	100.5	157.0	226.0	245.5	308.0	402.0	510.0	630.0
Nominal development length of bar in tension, $L_{sy,t(nom)}$ **	290	350	465	580	700	725	835	990	1160	1345
Effective length, L_{st} (mm)	Stress developed in steel, $\sigma_{st(nom)}$ (MPa)									
140	241									
160	276									
180	310	257								
240	414	343								
290	500	414	312							
310		443	333							
330		471	355							
350		500	376	302						
370			398	319						
410			441	353						
465			500	401	332	321				
490				422	350	338	293			
540				466	386	372	323	273		
580				500	414	400	347	293	250	
615					439	424	368	311	265	
650					464	448	389	328	280	242
700					500	483	419	354	302	260
725						500	434	366	312	270
780							467	394	336	290
835							500	422	360	310
875								442	377	325
915								462	394	340
990								500	427	368
1160									500	431
1345										500

500 Denotes adhesive tensile bond stress at Grade 500 steel yield development length, $L_{sy,t}$. Interpolation permitted. Do not extrapolate.

- *Note: 10, 36 & 40mm Reinforcing bar diameter data only applies to ChemSet™ Reo 502™ Plus and EPCON™ C8 Xtrem™
- **Note: 1. ChemSet™ Reo 502™ Plus and ChemSet™ 801 Xtrem™ XC² development length data is based on Diamond Core drilled holes.
 2. EPCON™ C8 Xtrem™ development data is based on hammer drilled holes. For Diamond Core drilled holes refer to Development Length multiplication factors below.
 3. When using 36 & 40mm Reinforcing bar diameter apply Development Length multiplication factors below.

Development Length Multiplication Factors on $L_{sy,t(nom)}$		
Chemical Anchor Type	Diamond Core Drill Factor	36mm and 40mm diameter factor
EPCON™ C8 Xtrem™	Multiply $L_{sy,t(nom)}$ x 1.2	Not required
ChemSet™ Reo 502™ Plus	Not required	Multiply $L_{sy,t(nom)}$ x 1.4

Chemset Reo 502™ Plus, Chemset 801 Xtrem™ XC² or EPCON™ C8 Xtrem™ STRENGTH LIMIT STATE DESIGN

Checkpoint **2a**

Table 2a Concrete compressive strength effect on development length, tension, X_{nc}

f_c (MPa)	20	25	32	40	50
X_{nc} - for 10-25 bar diam.	1.26	1.13	1.00	0.89	0.80
X_{nc} - for 28-32 bar diam.	1.26	1.13	1.00	1.00	1.00
X_{nc} - for 36-40 bar diam.	1.00	1.00	1.00	1.00	1.00

Design reinforcing bar steel development length, $L_{sy,t}$ (mm)

$$L_{sy,t} = L_{sy,t} \text{ (nom)} * X_{nc}$$

If there is insufficient concrete depth to install bar to $L_{sy,t}$
go to Checkpoint 2b

Note: Effect of water in hole, multiply $L_{sy,t}$ by 1.4.

Checkpoint **2b**

Table 2b Concrete compressive strength effect on steel stress, tension, X_{nc}

f_c (MPa)	20	25	32	40	50
X_{nc} - for 10-25 bar diam.	0.79	0.88	1.00	1.12	1.25
X_{nc} - for 28-32 bar diam.	0.79	0.88	1.00	1.00	1.00
X_{nc} - for 36-40 bar diam.	1.00	1.00	1.00	1.00	1.00

Design tensile steel stress, σ_{st} (MPa)

$$\sigma_{st} = \sigma_{st} \text{ (nom)} * X_{nc}$$

Note: Effect of water in hole, multiply σ_{st} by 0.7.

Chemset Reo 502™ Plus, Chemset 801 Xtrem™ XC² or EPCON™ C8 Xtrem™ STRENGTH LIMIT STATE DESIGN

Chemical Anchoring - Rebar to AS3600 & AS5216

Strength Limit State Design

Design Case **3** Multiple Bars in Concrete Elements (Medium clear anchor spacing)

Steel yield development length, $L_{sy,t}$ (AS5216-2021 Appendix D and AS3600 - 2018, clause 13.1.2.2)

Table 3 Nominal steel yield development length $L_{sy,t(nom)}$, of Grade 500 reinforcing bar in tension post-installed in 32 MPa concrete with ChemSet™ Reo 502™ Plus, Chemset™ 801 Xtrem™ XC² or EPCON™ C8 Xtrem™

Rebar size	10*	12	16	20	24	25	28	32	36*	40*
Concrete Splitting Factor, k_1	1.0	1.0	1.0	1.0	1.0	1.0	1.0	1.0	1.0	1.0
Concrete Splitting Factor, k_2	1.2	1.2	1.2	1.1	1.1	1.1	1.0	1.0	1.0	0.9
Concrete Splitting Factor, k_3	0.7	0.8	0.9	0.9	0.9	0.9	0.9	0.9	0.9	0.9
Minimum Cover, e (mm)	30	30	32	40	48	50	56	64	72	80
Min. Clear Spacing, a (mm)	60	60	70	80	100	100	120	130	150	150
Adhesive reduced ultimate tensile bond capacity ϕN_{ub} , (kN), $\phi_c = 0.6$	39.3	56.5	100.5	157.0	226.0	245.5	308.0	402.0	510.0	630.0
Nominal development length of bar in tension, $L_{sy,t(nom)**}$	290	350	520	675	835	880	1015	1205	1410	1670
Effective length, L_{st} (mm)	Stress developed in steel, $\sigma_{st(nom)}$ (MPa)									
120	207									
180	310									
200	345	286								
250	431	357								
290	500	414	279							
300		429	288							
330		471	317							
350		500	337	259						
400			385	296						
445			428	330						
520			500	385	311	295				
550				407	329	313	271			
595				441	356	338	293	247		
675				500	404	384	332	280	239	
700					419	398	345	290	248	
775					464	440	382	322	275	232
835					500	474	411	346	296	250
880						500	433	365	312	263
945							465	392	335	283
1015							500	421	360	304
1050								436	372	314
1120								465	397	335
1205								500	427	361
1410									500	422
1670										500

500 Denotes adhesive tensile bond stress at Grade 500 steel yield development length, $L_{sy,t}$. Interpolation permitted. Do not extrapolate.

*Note: 10, 36 & 40mm Reinforcing bar diameter data only applies to ChemSet™ Reo 502™ Plus and EPCON™ C8 Xtrem™

- **Note:
1. ChemSet™ Reo 502™ Plus and ChemSet™ 801 Xtrem™ XC² development length data is based on Diamond Core drilled holes.
 2. EPCON™ C8 Xtrem™ development data is based on hammer drilled holes. For Diamond Core drilled holes refer to Development Length multiplication factors below.
 3. When using 36 & 40mm Reinforcing bar diameter apply Development Length multiplication factors below.

Development Length Multiplication Factors on $L_{sy,t(nom)}$		
Chemical Anchor Type	Diamond Core Drill Factor	36mm and 40mm diameter factor
EPCON™ C8 Xtrem™	Multiply $L_{sy,t(nom)}$ x 1.2	Not required
ChemSet™ Reo 502™ Plus	Not required	Multiply $L_{sy,t(nom)}$ x 1.4

Chemset Reo 502™ Plus, Chemset 801 Xtrem™ XC² or EPCON™ C8 Xtrem™ STRENGTH LIMIT STATE DESIGN

Checkpoint **3a**

Table 3a Concrete compressive strength effect on development length, tension, X_{nc}

f_c (MPa)	20	25	32	40	50
X_{nc} - for 10-25 bar diam.	1.26	1.13	1.00	0.89	0.80
X_{nc} - for 28-32 bar diam.	1.26	1.13	1.00	1.00	1.00
X_{nc} - for 36-40 bar diam.	1.00	1.00	1.00	1.00	1.00

Design reinforcing bar steel development length, $L_{sy,t}$ (mm)

$$L_{sy,t} = L_{sy,t} (nom) * X_{nc}$$

If there is insufficient concrete depth to install bar to $L_{sy,t}$
go to Checkpoint 3b

Note: Effect of water in hole, multiply $L_{sy,t}$ by 1.4.

Checkpoint **3b**

Table 3b Concrete compressive strength effect on steel stress, tension, X_{nc}

f_c (MPa)	20	25	32	40	50
X_{nc} - for 10-25 bar diam.	0.79	0.88	1.00	1.12	1.25
X_{nc} - for 28-32 bar diam.	0.79	0.88	1.00	1.00	1.00
X_{nc} - for 36-40 bar diam.	1.00	1.00	1.00	1.00	1.00

Design tensile steel stress, σ_{st} (MPa)

$$\sigma_{st} = \sigma_{st} (nom) * X_{nc}$$

Note: Effect of water in hole, multiply σ_{st} by 0.7.

Chemset Reo 502™ Plus, Chemset 801 Xtrem™ XC² or EPCON™ C8 Xtrem™ STRENGTH LIMIT STATE DESIGN

Chemical Anchoring - Rebar to AS3600 & AS5216

Strength Limit State Design

Design Case **4** Multiple Bars in Concrete Elements (Minimum clear anchor spacing)

Steel yield development length, $L_{sy,t}$ (AS5216-2021 Appendix D and AS3600 - 2018, clause 13.1.2.2)

Table 4 Nominal steel yield development length $L_{sy,t(nom)}$ of Grade 500 reinforcing bar in tension post-installed in 32 MPa concrete with ChemSet™ Reo 502™ Plus, Chemset™ 801 Xtrem™ XC² or EPCON™ C8 Xtrem™

Rebar size	10*	12	16	20	24	25	28	32	36*	40*
Concrete Splitting Factor, k_1	1.0	1.0	1.0	1.0	1.0	1.0	1.0	1.0	1.0	1.0
Concrete Splitting Factor, k_2	1.2	1.2	1.2	1.1	1.1	1.1	1.0	1.0	1.0	0.9
Concrete Splitting Factor, k_3	0.9	0.9	0.9	0.9	0.9	0.9	0.9	0.9	0.9	0.9
Minimum Cover, e (mm)	30	30	32	40	48	50	56	64	72	80
Min. Clear Spacing, a (mm)	30	36	48	60	72	75	84	96	108	120
Adhesive reduced ultimate tensile bond capacity ϕN_{ub} , (kN), $\phi_c = 0.6$	39.3	56.5	100.5	157.0	226.0	245.5	308.0	402.0	510.0	630.0
Nominal development length of bar in tension, $L_{sy,t(nom)}$ **	335	410	565	730	910	965	1105	1310	1535	1780
Effective length, L_{st} (mm)	Stress developed in steel, σ_{st} (nom) (MPa)									
150	224									
200	299									
250	373	305								
290	433	354								
335	500	409	296							
350		427	310	$\sigma_{st} < f_{sy}$						
390		476	345							
410		500	363							281
450			398	308						
480			425	329						
565			500	387	310	293				
600				411	330	311	272			
650				445	357	337	294	248		
730				500	401	378	330	279	238	
780					428	404	353	298	254	
850					467	440	385	324	277	239
910					500	472	412	347	297	256
965						500	437	368	314	271
1030							466	393	336	289
1105							500	422	360	310
1200								458	391	337
1250								477	407	351
1310								500	427	368
1535									500	431
1780										500

500 Denotes adhesive tensile bond stress at Grade 500 steel yield development length, $L_{sy,t}$
Interpolation permitted. Do not extrapolate.

*Note: 10, 36 & 40mm Reinforcing bar diameter data only applies to ChemSet™ Reo 502™ Plus and EPCON™ C8 Xtrem™

- **Note:
1. ChemSet™ Reo 502™ Plus and ChemSet™ 801 Xtrem™ XC² development length data is based on Diamond Core drilled holes.
 2. EPCON™ C8 Xtrem™ development data is based on hammer drilled holes. For Diamond Core drilled holes refer to Development Length multiplication factors below.
 3. When using 36 & 40mm Reinforcing bar diameter apply Development Length multiplication factors below.

Development Length Multiplication Factors on $L_{sy,t(nom)}$		
Chemical Anchor Type	Diamond Core Drill Factor	36mm and 40mm diameter factor
EPCON™ C8 Xtrem™	Multiply $L_{sy,t(nom)}$ x 1.2	Not required
ChemSet™ Reo 502™ Plus	Not required	Multiply $L_{sy,t(nom)}$ x 1.4

Chemset Reo 502™ Plus, Chemset 801 Xtrem™ XC² or EPCON™ C8 Xtrem™ STRENGTH LIMIT STATE DESIGN

Checkpoint **4a**

Table 4a Concrete compressive strength effect on development length, tension, X_{nc}

f_c (MPa)	20	25	32	40	50
X_{nc} - for 10-25 bar diam.	1.26	1.13	1.00	0.89	0.80
X_{nc} - for 28-32 bar diam.	1.26	1.13	1.00	1.00	1.00
X_{nc} - for 36-40 bar diam.	1.00	1.00	1.00	1.00	1.00

Design reinforcing bar steel development length, $L_{sy,t}$ (mm)

$$L_{sy,t} = L_{sy,t} \text{ (nom)} * X_{nc}$$

If there is insufficient concrete depth to install bar to $L_{sy,t}$
go to Checkpoint 4b

Note: Effect of water in hole, multiply $L_{sy,t}$ by 1.4.

Checkpoint **4b**

Table 4b Concrete compressive strength effect on steel stress, tension, X_{nc}

f_c (MPa)	20	25	32	40	50
X_{nc} - for 10-25 bar diam.	0.79	0.88	1.00	1.12	1.25
X_{nc} - for 28-32 bar diam.	0.79	0.88	1.00	1.00	1.00
X_{nc} - for 36-40 bar diam.	1.00	1.00	1.00	1.00	1.00

Design tensile steel stress, σ_{st} (MPa)

$$\sigma_{st} = \sigma_{st} \text{ (nom)} * X_{nc}$$

Note: Effect of water in hole, multiply σ_{st} by 0.7.

Introduction

MECHANICAL ANCHORING

[Back to index](#)

Mechanical Anchoring



Ramset™ has been offering mechanical anchors in the Australia and New Zealand market place for over 50 years. During this time **Ramset™** brand names have entered into common language on building sites all over Australia and New Zealand. Names like DynaBolt™ and TruBolt™ have become recognised as the best sleeve anchors and stud anchors alike. But only **Ramset™** supplies the original, proven products like DynaBolt™ Plus sleeve anchors, TruBolt™ stud anchors, SpaTec™ Plus safety anchors, WERCS AnkaScrew™ screw-in anchors and DynaSet™ internally threaded anchors. These tried and tested **Ramset™** brand names represent Quality, Reliability and Performance. The **Ramset™ ISO9001 accreditation** assures it.

Not only does **Ramset™** offer reliable, quality products, **Ramset™** understands masonry anchoring technology and offers published information, such as this book, to guide correct product selection and safe installation. Extensive research, development and testing are invested in **Ramset™** products so that designers can be secure in the knowledge that they have access to the real performance and capabilities of the anchors.

It is performance that defines an anchor's capabilities. An anchor's performance cannot be deduced from its description. For example not all sleeve anchors perform like DynaBolt™ Plus sleeve anchors and not all stud anchors perform like TruBolt™ stud anchors. Product design, manufacturing tolerances and manufacturing quality control has a

major effect on anchor performance. The only way to determine an anchor's actual performance is to measure it at all of its design and tolerance limits. The performance of **Ramset™** Anchors are determined by extensive and rigorous testing to enable us to provide information on how our products will perform over a wide range of conditions and advise as to their limitations.

The correct anchor for a particular load case can only be selected by referring to reliable design information issued by the supplier for their anchors. Performance and design information from one supplier does not apply to anchors from other suppliers, even if they appear to be the same or have the same generic description.

The following section introduces the designer and/or engineer to the **Ramset™** mechanical anchoring range and provides performance information to allow selection of the right anchor for the job.

SpaTec™ Xtrem™

SAFETY ANCHORS - NON-CRACKED & CRACKED CONCRETE

[Back to index](#)

GENERAL INFORMATION

Performance Related	Material	Installation Related

Product

A high security, high performance, through fixing, torque controlled expansion anchor which has approval for use in cracked and non-cracked concrete.

Benefits, Advantages and Features

European Technical Approval (option1) – ETA-10/0276:
 Design According to AS5216 (formerly TS101) and European design method EN 1992-4 (formerly ETAG001 Annex C & TR045)

- CISM Report Anchors exposed to seismic actions NTC022
- Highest level of European approval for mechanical expansion anchors
- Approved for all directions (floor, wall, overhead)
- Shallow embedment depths
- Highest performance in cracked concrete
- Zinc Plated to 5µm
- Anchor diameters from M10 to M20

Use Ramset™ iExpert Anchor Software for optimised calculation or where a greater range of anchor layout detail is needed.

Suitable for structural loads:

- Safety critical loads
- High tensile capacity of Grade 8.8 Steel Bolt.
- Heavy duty, heat treated washer. Heavy duty, thick expansion sleeve that provides secure grip to concrete.

Improved security:

- Large expansion reserve that ensures retention in concrete if overloaded.
- Torque induced pull down closes gaps and induces preload.

Resistant to cyclic loading:

- Heavy duty sleeve with integrated pull-down section works to retain 65% of initial preload.

Fast installation:

- Hex Nut & Hex Bolt versions available
- Countersunk heads available.
- Through fixing eliminates marking out and repositioning of fixtures.

Fire rated: Refer Fire rated mechanical anchor section.

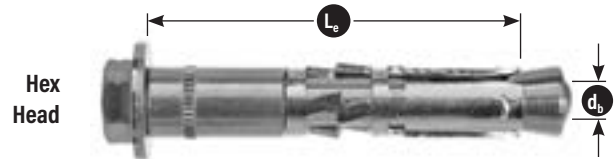

Principal Applications

- Anchoring into cracked & non cracked concrete
- Safety critical loads
- Steel columns & walkways
- Road barrier hold down
- Bridge refurbishment
- Road & Rail tunnel construction
- Wall Plates
- Safety Rails
- Intended working life of the anchor of 50 years

Installation

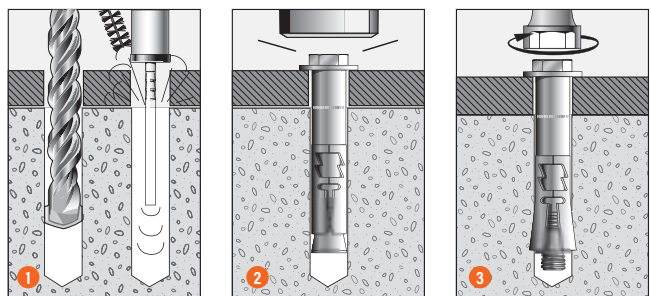

1. Drill or core a hole to the recommended diameter and depth using the fixture as a template. Clean the hole thoroughly with a hole cleaning brush. Remove the debris with a hand pump, compressed air, or vacuum.
2. After ensuring that the anchor is assembled correctly, insert the anchor through the fixture and drive with a hammer until the washer contacts the fixture.
3. Tighten the bolt with a torque wrench to the specified assembly torque.

SpaTec™ Xtrem™

SAFETY ANCHORS - NON-CRACKED & CRACKED CONCRETE

Mechanical Anchoring

Installation and performance details

Anchor size, d_b (mm)	Drilled hole diameter, d_h (mm)	Fixture hole diameter, d_f (mm)	Anchor effective depth, h (mm)	Depth of drill hole, h_1 (mm)	Tightening torque, T_r (Nm)	Concrete substrate thickness, b_m (mm)	Non-Cracked Concrete Tension, ϕN_{uc} (kN)**		
							Concrete Compressive Strength, f'_c		
							20 MPa	32 MPa	40 MPa
M10	15	17	70	90	50	140	19.1	24.2	27.1
M12	18	20	80	105	80	160	23.4	29.6	33.1
M16	24	26	100	131	120	200	32.7	41.4	46.3
M20	28	30	125	157	200	250	45.8	57.9	64.7

* Note: For shear loads acting towards an edge or where these optimum dimensions are not achievable, please use the simplified strength limit state design process to verify capacity.

** Data is based on optimal dimensions, anchor spacing = $3 \times h$, edge distance = $1.5 \times h$

** Note: Reduced characteristic ultimate concrete tensile capacity = ϕN_{uc} where $\phi = 0.67$ and N_{uc} = Characteristic ultimate concrete tensile capacity.

For conversion to Working Load Limit MULTIPLY $\phi N_{uc} \times 0.50$

For Cracked Concrete performance, please use the simplified strength limit state design process to verify capacity.

DESCRIPTION AND PART NUMBERS

Anchor size, d_b (mm)	Drilled hole diameter, d_h (mm)	Effective Length, L_e (mm)	Fixture thickness, t (mm)	ETA Designation Number	Part Number
					Zinc (Hex Hd)
M10	15	90	20	V10-15/20	SP10105
M12	18	90	10	V12-18/10	SP12105
		105	25	V12-18/25	SP12120
M16	24	125	25	V16-24/25	SP16145
M20	28	150	25	V20-28/25	SP20170

ENGINEERING PROPERTIES

Description	Material	Protection
Cone	1.0765 steel EN 10 087	Galvanised 5 μ m
Expansion Sleeve	1.5330 steel EN 10 149-2	Galvanised 5 μ m
Distance sleeve	TS37 a BK or S300Pb NF A 49 341	Galvanised 5 μ m
Threaded rod	1. Steel Grade 8.8 EN 20 898-1	Galvanised 5 μ m
Screw	1. Steel Grade 8.8 EN 20 898-1	Galvanised 5 μ m
Washer	HLE S550MC	Galvanised 5 μ m
Hexagonal Nut	Grade 8 EN 20 898-2	Galvanised 5 μ m

SpaTec™ Xtrem™

SAFETY ANCHORS - NON-CRACKED & CRACKED CONCRETE

STEP 1 Select anchor to be evaluated

Table 1a - Indicative combined loading - interaction diagram

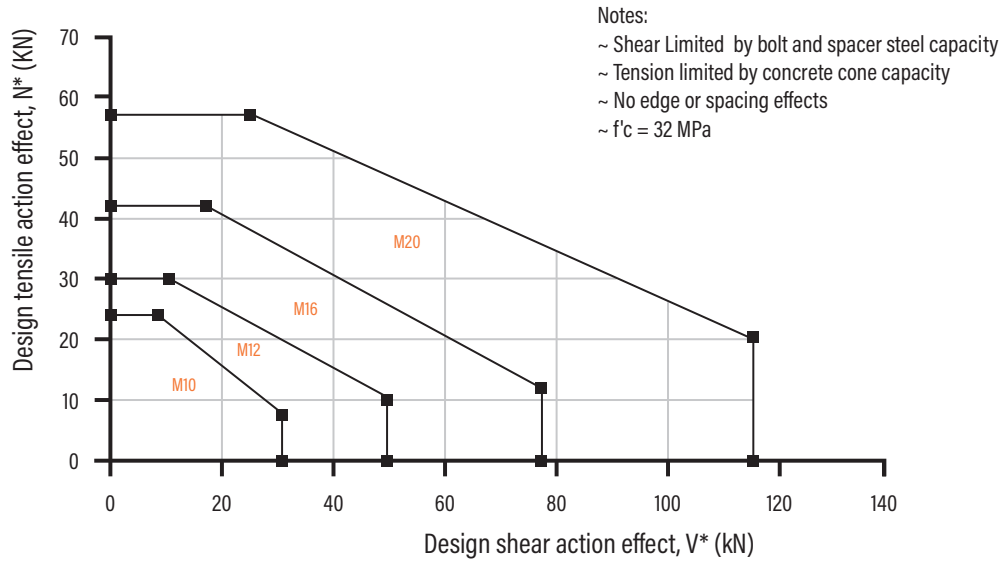

Table 1b Absolute minimum edge distance and anchor spacing values, e_m and a_m (mm)

Anchor size, d _b	M10	M12	M16	M20
Effective depth, h (mm)	70	80	100	125
Min. Anchor spacing - a _m	70	80	100	125
For - e _m	100	160	180	300
Min. Edge Distance - e _m	70	80	100	150
For - a _m	160	200	220	300

Step 1c Calculate anchor effective depth, h (mm)

Refer to "Description and Part Numbers" table in the SARB ANZ on the previous page.

Effective depth, h (mm)

$$h = L_e - t$$

t = total thickness of material(s) being fixed

Checkpoint

1

Anchor size determined, absolute minimum compliance achieved, effective depth (h) calculated.

SpaTec™ Xtrem™

STRENGTH LIMIT STATE DESIGN

Mechanical Anchoring

STEP 2

Verify concrete tensile capacity - per anchor

Table 2a - Reduced characteristic ultimate concrete tensile capacity, ϕN_{uc} (kN), $\phi_c = 0.67$, $f'_c = 32$ MPa

Anchor size, d_b	M10	M12	M16	M20
Drill hole dia, d_h (mm)	15	18	24	28
Effective depth, h (mm)				
70	24.2			
80		29.6		
100			41.4	
125				57.9

For optimised performance data, please use Ramset iExpert Anchoring Software.

Table 2a-2 Cracked Concrete effect, tension, X_{ncr}

Anchor Size d_b	M10	M12	M16	M20
X_{ncr}	0.67	0.70	0.70	0.70

For Non-cracked concrete $X_{ncr} = 1.0$

Table 2b - Concrete compressive strength effect, tension, X_{nc}

f'_c (MPa)	20	25	32	40	50
X_{nc}	0.79	0.88	1.00	1.12	1.25

Table 2c - Concrete Edge distance effect, tension, X_{ne}

Anchor size, d_b	10	12	16	20
Edge distance, e (mm)				
70	0.75			
80	0.82	0.75		
90	0.89	0.81		
100	0.96	0.88	0.75	0.65
120	1.00	1.00	0.85	0.73
150			1.00	0.85
165				0.91
187				1.00

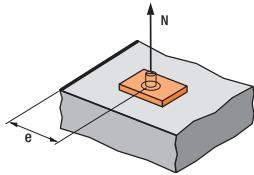

$$X_{ne} = 0.25 + 0.5*(e/h)$$

Where $e_m \leq e \leq e_c$

$$e_c = 1.5*h$$

Note: Tabled values are based on the nominal effective depth, h shown in the installation details. For other values of X_{ne} , please use equation shown above.

Table 2d - Concrete anchor spacing effect, tension, X_{na}

Anchor size, d_b	M10	M12	M16	
Anchor spacing, a (mm)				
70	0.67			
80	0.69	0.67		
100	0.74	0.71	0.67	
125	0.80	0.76	0.71	0.67
150	0.86	0.81	0.75	0.70
180	0.93	0.88	0.80	0.74
210	1.00	0.94	0.85	0.78
240		1.00	0.90	0.82
300			1.00	0.90
330				0.94
375				1.00

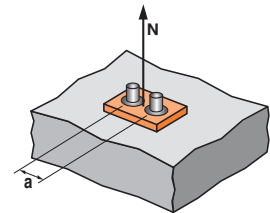

$$X_{na} = 0.5 + a/(6*h)$$

Where $a_m \leq a \leq a_c$

$$a_c = 3*h$$

Note: Tabled values are based on the nominal effective depth, h shown in the installation details. For other values X_{na} , please use equation shown above.

Checkpoint 2

Design reduced ultimate concrete tensile capacity, ϕN_{urc}

$$\phi N_{urc} = \phi N_{uc} * X_{ncr} * X_{nc} * X_{ne} * X_{na}$$

SpaTec Xtrem™

STRENGTH LIMIT STATE DESIGN

STEP 3

Verify Anchor tensile capacity - per anchor

Table 3a Reduced characteristic ultimate steel tensile capacity, ϕN_{usr} (kN) where $\phi_n = 1/1.5 = 0.67$

Anchor size, d_b	M10	M12	M16	M20
Carbon Steel	30.5	44.7	84.0	130.7

Table 3b-1 Reduced characteristic ultimate pull-out capacity, ϕN_{up} (kN), $\phi = 0.67$, $f'_c = 32$ MPa

Anchor size, d_b	M10	M12	M16	M20
Drill hole dia d_h (mm)	15	18	24	28
Effective depth, h (mm)				
70	24.2			
80		N/A		
100			N/A	
125				N/A

Table 3b-2 Cracked Concrete effect, pull-out, X_{pcr}

Anchor size, d_b	M10	M12	M16	M20
X_{pcr}	0.534	N/A	N/A	N/A

Note: For Non-Cracked Concrete, $X_{pcr} = 1.0$

Checkpoint 3a

Design reduced ultimate pull-out capacity, ϕN_{urp}

$$\phi N_{urp} = \phi N_{up} * X_{pcr} * X_{npc}$$

Checkpoint 3b

Design reduced ultimate tensile capacity, ϕN_{ur}

$$\phi N_{ur} = \text{minimum of } \phi N_{urc}, \phi N_{urp}, \phi N_{us}$$

Check $N^*/\phi N_{ur} \leq 1$,

if not satisfied return to step 1

SpaTec Xtrem™

STRENGTH LIMIT STATE DESIGN

Mechanical Anchoring

STEP 4

Verify concrete shear capacity - per anchor

Table 4a Reduced characteristic ultimate concrete edge shear capacity, ϕV_{uc} (kN), $\phi = 1/1.5 = 0.67$, $f'_c = 32$ MPa

Anchor size, d_b	M10	M12	M16	M20
Effective depth, h (mm)	60	70	85	100
Edge distance, e_m				
70	8.3			
80		11.3		
100			16.6	
150				31.8

For optimised performance data, please use Ramset iExpert Anchoring Software.

Table 4a-2 Cracked Concrete effect, shear, X_{vcr}

Anchor Size d_b	M10	M12	M16	M20
X_{vcr}	0.70			

For Non-cracked concrete $X_{vcr} = 1.0$

Table 4b Concrete compressive strength effect, concrete edge shear, X_{vc}

f'_c (MPa)	20	25	32	40	50
X_{vc}	0.82	0.90	1.00	1.16	1.27

Table 4c - Concrete load direction effect, concrete edge shear, X_{vd}

Angle, α°	0-55	60	70	80	90-180
X_{vd}	1	1.1	1.2	1.5	2

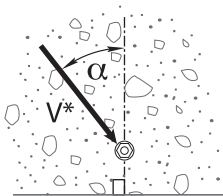

Load direction effect, conc. edge shear, X_{vd}

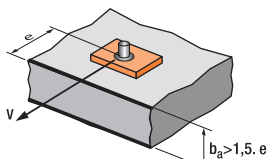

$$X_{ve} = e/e_m * \sqrt{e/e_m}$$

Table 4d - Seismic cracked concrete anchor spacing and edge distance effect, concrete edge shear, X_{ve}

For single anchor fastening X_{ve}

e/e_m	1.0	1.2	1.4	1.6	1.8	2.0	2.2	2.4	2.6	2.8	3.0	3.2
X_{ve}	1.00	1.31	1.66	2.02	2.41	2.83	3.26	3.72	4.19	4.69	5.20	5.72

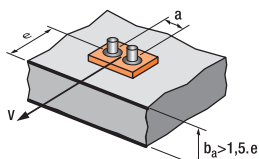

$$X_{ve} = \frac{3*e+a}{6*e_m} * \sqrt{e/e_m}$$

For 2 anchors fastening X_{ve}

e/e_m	1.0	1.2	1.4	1.6	1.8	2.0	2.2	2.4	2.6	2.8	3.0	3.2
a/e_m												
1.0	0.67	0.84	1.03	1.22	1.43	1.65	1.88	2.12	2.36	2.62	2.89	3.16
1.5	0.75	0.93	1.12	1.33	1.54	1.77	2.00	2.25	2.50	2.76	3.03	3.31
2.0	0.83	1.02	1.22	1.43	1.65	1.89	2.12	2.38	2.63	2.90	3.18	3.46
2.5	0.92	1.11	1.32	1.54	1.77	2.00	2.25	2.50	2.77	3.04	3.32	3.61
3.0	1.00	1.20	1.42	1.64	1.88	2.12	2.37	2.63	2.90	3.18	3.46	3.76
3.5		1.30	1.52	1.75	1.99	2.24	2.50	2.76	3.04	3.32	3.61	3.91
4.0			1.62	1.86	2.10	2.36	2.62	2.89	3.17	3.46	3.75	4.05
4.5				1.96	2.21	2.47	2.74	3.02	3.31	3.60	3.90	4.20
5.0					2.33	2.59	2.87	3.15	3.44	3.74	4.04	4.35
5.5						2.71	2.99	3.28	3.71	4.02	4.33	4.65
6.0							2.83	3.11	3.41	3.71	4.02	4.33

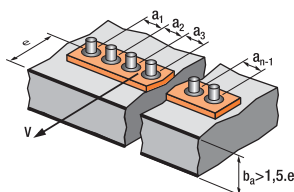

For 3 anchors fastening and more X_{ve}

$$X_{ve} = \frac{3*e + a_1 + a_2 + a_3 + \dots + a_{n-1}}{3*n*e_m} * \sqrt{e/e_m}$$

SpaTec Xtrem™

STRENGTH LIMIT STATE DESIGN

Table 4e Reduced characteristic ultimate concrete pryout capacity, ϕV_{ucp} (kN), $\phi = 1/1.5 = 0.67$, $f'_c = 32$ MPa

Anchor size, d_b	M10	M12	M16	M20
Effective depth, h (mm)	60	70	85	100
Edge distance, e				
70	48.6			
80		59.4		
100			83.0	
150				116.0

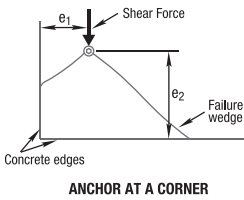

Table 4f Anchor at a corner effect, concrete edge shear, X_{vs}

Note: For $e_1/e_2 > 1.25$, $X_{vs} = 1.0$

Edge distance, e_2 (mm)	25	30	35	50	60	75	125	200	300	400	600	900
Edge distance, e_1 (mm)												
25	0.86	0.77	0.70	0.58	0.53	0.49	0.41	0.37	0.35	0.34	0.32	0.32
30	0.97	0.86	0.78	0.64	0.58	0.52	0.43	0.38	0.36	0.34	0.33	0.32
35	1.00	0.95	0.86	0.69	0.63	0.56	0.46	0.40	0.37	0.35	0.33	0.32
50	1.00	1.00	1.00	0.86	0.77	0.67	0.52	0.44	0.39	0.37	0.35	0.33
60	1.00	1.00	1.00	0.97	0.86	0.75	0.57	0.47	0.41	0.38	0.36	0.34
75	1.00	1.00	1.00	1.00	1.00	0.86	0.64	0.51	0.44	0.41	0.37	0.35
125	1.00	1.00	1.00	1.00	1.00	1.00	0.86	0.65	0.53	0.48	0.42	0.38
200	1.00	1.00	1.00	1.00	1.00	1.00	1.00	0.86	0.67	0.58	0.49	0.42
300	1.00	1.00	1.00	1.00	1.00	1.00	1.00	1.00	0.86	0.72	0.58	0.49
400	1.00	1.00	1.00	1.00	1.00	1.00	1.00	1.00	1.00	0.86	0.67	0.55
500	1.00	1.00	1.00	1.00	1.00	1.00	1.00	1.00	1.00	1.00	0.77	0.61
600	1.00	1.00	1.00	1.00	1.00	1.00	1.00	1.00	1.00	1.00	0.86	0.67
900	1.00	1.00	1.00	1.00	1.00	1.00	1.00	1.00	1.00	1.00	1.00	0.86

Checkpoint **4a**

Design reduced ultimate concrete edge shear capacity, ϕV_{urc}

$$\phi V_{urc} = \phi V_{uc} * X_{vcr} * X_{vc} * X_{vd} * X_{ve} * X_{vs}$$

Checkpoint **4b**

Design reduced ultimate concrete pryout capacity, ϕV_{urcp}

$$\phi V_{urcp} = \phi V_{ucp} * X_{ncr} * X_{nc} * X_{ne} * X_{na}$$

STEP 5

Verify anchor shear capacity - per anchor

Table 5a Reduced characteristic ultimate steel shear capacity, ϕV_{us} (kN) where $\phi_v = 0.67$

Anchor size, d_b	M10	M12	M16	M20
Carbon Steel	32.9	48.7	78.5	116.2

Checkpoint **5**

Design reduced ultimate shear capacity, ϕV_{ur}

$$\phi V_{ur} = \text{minimum of } \phi V_{urc}, \phi V_{urcp}, \phi V_{us}$$

Check $V^*/\phi V_{ur} \leq 1$,
if not satisfied return to step 1

SpaTec™ Xtrem™

STRENGTH LIMIT STATE DESIGN

Mechanical Anchoring

STEP 6 Combined loading and specification

Checkpoint 6

Check

$$N^*/\phi N_{ur} + V^*/\phi V_{ur} \leq 1.2,$$

if not satisfied return to step 1

Specify

Ramset™ SpaTec™ Xtrem™ Anchor,
(Anchor Size) (Part Number)
Maximum fixed thickness to be (t) mm.

Example

Ramset™ SpaTec™ Xtrem™ Anchor, M12 (SP12120).
Maximum fixed thickness to be 8 mm. To be installed in
accordance to Ramset™ Installation Instructions.

Boa™ Coil

EXPANSION ANCHORS - NON-CRACKED CONCRETE

[Back to index](#)

GENERAL INFORMATION

Performance Related	Material	Installation Related

Product

The Boa™ Coil Anchor is a heavy duty, rotation setting expansion anchor.

Benefits, Advantages and Features

High load capacity:

- Expansion coil locks into concrete to give cast-in type performance.
- High tensile capacity of grade 8.8 steel bolt.

High clamping load:

- Rotation setting action pulls down.

Resistant to cyclic loading:

- Pull-down action.

Fast installation:

- Through fixing eliminates marking out and repositioning of fixtures.

Easy and fast to remove:

- Expansion coil stays in hole leaving no protruding metal parts to grind off.

Ramset Design Method:

- Uses technical data validated from testing in ANZ concrete substrates

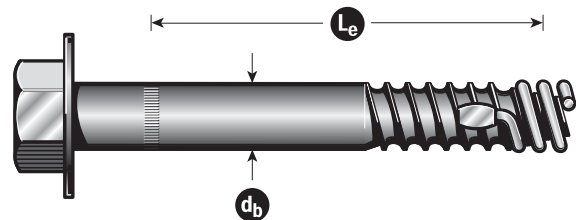

Principal Applications

- Installing handrails and balustrades
- Machinery hold down
- Formwork support
- Safety barriers
- Scaffolding

Installation

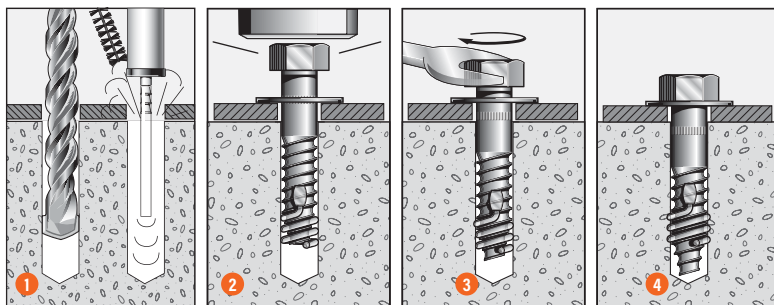

1. Drill or core a hole to the recommended diameter and depth using the fixture as a template. Clean the hole thoroughly with a hole cleaning brush. Remove the debris with a hand pump, compressed air, or vacuum.
2. After ensuring that the anchor is assembled correctly (the coil tab points up the anchor), insert the anchor through the fixture.
3. Tap the anchor down to the depth set mark, with a hammer, and stop.
4. Wind the anchor down, with an appropriately sized spanner or socket wrench, until the washer is firmly held to the fixture and stop (5 turns). Ensure washer is tight and snug fit.
5. The Boa™ Coil anchor is ready to take load. (The bolt can be removed leaving the coil in the hole. To re-insert, follow steps 3 - 4.)

Boa™ Coil

EXPANSION ANCHORS - NON-CRACKED CONCRETE

Mechanical Anchoring

Installation and performance details

Anchor Size, d_b (mm)	Installation details				Optimum dimensions*		Reduced Characteristic Capacity			
	Drilled Hole diam., d_h (mm)	Fixture hole diameter, d_f (mm)	Anchor effective depth, h (mm)	Turns to set anchor	Edge distance, e_c (mm)	Anchor spacing, a_c (mm)	Steel	Non-Cracked Concrete		
							Shear, ΦV_{us} (kN)	Tension, ΦN_{uc} (kN)**		
								Concrete compressive strength, f'_c		
20 MPa	32 MPa	40 MPa								
13	13	14	40	5	80	160	16.4	9.6	12.1	13.5
			75				30.8	17.9	22.7	25.3
			110				32.0	26.3	33.2	37.2
16	16	19	50	5	100	200	28.9	14.7	18.6	20.8
			70				40.3	20.6	26.0	29.1
			90				51.8	26.5	33.5	37.4
19	19	21	57	5	120	230	40.3	19.9	25.2	28.2
			80				56.6	27.9	35.3	39.5
			90				63.6	31.4	39.8	44.5

* Note: For shear loads acting towards an edge or where these optimum dimensions are not achievable, please use the simplified strength limit state design process to verify capacity.

**Note: Reduced characteristic ultimate concrete tensile capacity = ΦN_{uc} where $\Phi = 0.6$ and N_{uc} = Characteristic ultimate concrete tensile capacity.

For conversion to Working Load Limit MULTIPLY ΦN_{uc} x 0.55

All data relevant for Non-cracked concrete

DESCRIPTION AND PART NUMBERS

Anchor size, d_b (mm)	Effective length, L_e (mm)	Part No. Zn
13	59	BAC08075
	84	BAC08100
16	71	BAC10090
	106	BAC10125
19	93	BAC12115

Effective depth, h (mm)

$$h = L_e - t$$

t = total thickness of material(s) being fixed

Substrate thickness, b_m (mm)

$$b_m = h + (5 \times d_h)$$

Drilled hole depth, h_1 (mm)

$$h_1 = h + (3 \times d_h)$$

h = Effective depth

ENGINEERING PROPERTIES - Carbon Steel

Anchor size, d_b (mm)	Bolt stress area, A_s (mm ²)	Bolt yield strength, f_y (MPa)	Bolt UTS, f_u (MPa)	Section modulus, Z (mm ³)
13	77.8	680	830	97.0
16	134.4	680	830	219.8
19	196.0	680	830	387.2

Boa™ Coil

STRENGTH LIMIT STATE DESIGN

STEP 1 Select anchor to be evaluated

Table 1a Indicative combined loading - interaction diagram

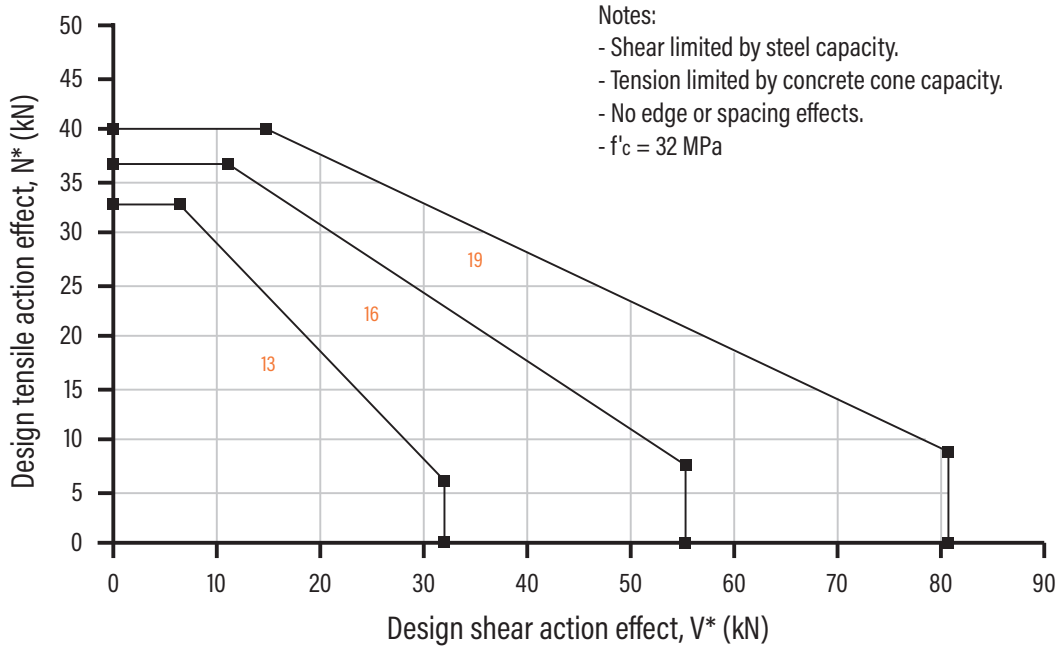

Table 1b Absolute minimum edge distance and anchor spacing values, e_m and a_m (mm)

Anchor size, d_b (mm)	13	16	19	
Edge distance, e_m	65	80	95	
Anchor spacing, a_m	$e \geq 6 d_b$	105	130	150
	$e < 6 d_b$	130	160	190

Step 1c Calculate anchor effective depth, h (mm)

Refer to "Description and Part Numbers" table on the previous page.

Effective depth, h (mm)

$h = L_e - t$

t = total thickness of material(s) being fixed

Checkpoint 1 Anchor size determined, absolute minima compliance achieved, effective depth (h) calculated.

Boa™ Coil

STRENGTH LIMIT STATE DESIGN

Mechanical Anchoring

STEP 2 Verify concrete tensile capacity - per anchor

Table 2a Reduced characteristic ultimate concrete tensile capacity, ϕN_{uc} (kN), $\phi_c = 0.6$, $f'_c = 32$ MPa

Anchor size, d_b (mm)	13	16	19
Effective depth, h (mm)			
40	12.1		
45	13.6		
50	15.1	18.6	
55	16.6	20.5	
60	18.1	22.3	26.5
70	21.2	26.0	30.9
80	24.2	29.8	35.3
90	27.2	33.5	39.8
100	30.2	37.2	
105	31.7		
110	33.2		

Note: Effective depth, h must be $\geq 3 \times$ anchor size, d_b in order to achieve tabled shear capacities.
All data relevant for Non-cracked concrete

Table 2b Concrete compressive strength effect, tension, X_{nc}

f'_c (MPa)	20	25	32	40	50
X_{nc}	0.79	0.88	1.00	1.12	1.25

Table 2c Edge distance effect, tension, X_{ne}

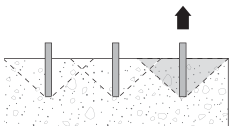

Anchor size, d_b (mm)	13	16	19
Edge distance, e (mm)			
70	0.93		
80	1.00	0.88	
90		0.96	
100		1.00	0.91
120			1.00

Table 2d Anchor spacing effect, end of a row, tension, X_{nae}

Note: For single anchor designs, $X_{nae} = 1.0$

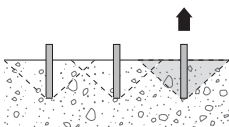

Anchor size, d_b (mm)	13	16	19
Anchor spacing, a (mm)			
100	0.82		
120	0.88		
140	0.95	0.86	
160	1.00	0.92	0.85
180		0.97	0.89
200		1.00	0.94
220			0.98
230			1.00

Boa™ Coil

STRENGTH LIMIT STATE DESIGN

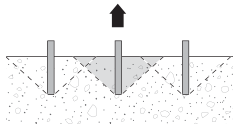

Table 2e Anchor spacing effect, internal to a row, tension, X_{nai}

Note: For single anchor designs, $X_{nai} = 1.0$

Anchor size, d_b (mm)	13	16	19
Anchor spacing, a (mm)			
100	0.64		
120	0.77		
140	0.90	0.73	
150	0.96	0.78	0.66
160	1.00	0.83	0.70
180		0.94	0.79
200		1.00	0.88
220			0.96
230			1.00

Checkpoint 2

Design reduced ultimate concrete tensile capacity, ϕN_{urc}

$$\phi N_{urc} = \phi N_{uc} * X_{nc} * X_{ne} * (X_{nae} \text{ or } X_{nai})$$

STEP 3

Verify anchor tensile capacity - per anchor

Table 3a Reduced characteristic ultimate steel tensile capacity, ϕN_{us} (kN), $\phi_n = 0.8$

Anchor size, d_b (mm)	13	16	19
Carbon steel	51.7	89.2	130.1

Checkpoint 3

Design reduced ultimate tensile capacity, ϕN_{ur}

$$\phi N_{ur} = \text{minimum of } \phi N_{urc}, \phi N_{us}$$

Check $N^* / \phi N_{ur} \leq 1$,

if not satisfied return to step 1

Tensile performance conversion table

Performance Required	Concrete Tensile Performance		Steel Tensile Performance	
	Notation	Concrete Tension Capacity	Notation	Carbon Steel Tension Capacity
Strength Limit State	ϕN_{urc}	MULTIPLY $\phi N_{urc} \times 1.00$	ϕN_{us}	MULTIPLY $\phi N_{us} \times 1.00$
Working Load Limit	N_{ac}	MULTIPLY $\phi N_{urc} \times 0.55$	N_{as}	MULTIPLY $\phi N_{us} \times 0.56$
Cyclic Loading	N_{yc}	MULTIPLY $\phi N_{urc} \times 0.55$	N_{ys}	MULTIPLY $\phi N_{us} \times 0.56$
Fire Resistance	$N_{Rk,c,fit}$	Refer to Fire Rated Anchors	$N_{Rk,s,fit}$	Refer to Fire Rated Anchors
Seismic	$N_{Rd,p,sis}^0$	Refer to Seismic Anchors	$N_{Rd,s,sis}$	Refer to Seismic Anchors

NOTE: Design Tensile Capacity is the minimum of Concrete Tension and Steel Tension Capacities

Boa™ Coil

STRENGTH LIMIT STATE DESIGN

Mechanical Anchoring

STEP 4 Verify concrete shear capacity - per anchor

Table 4a Reduced characteristic ultimate concrete edge shear capacity, ϕV_{uc} (kN), $\phi_c = 0.6$, $f_c = 32$ MPa

Anchor size, d_b (mm)	13	16	19
Edge distance, e (mm)			
70	8.7		
80	10.7	11.9	
100	14.9	16.6	18.0
150	27.4	30.4	33.2
200	42.2	46.8	51.1
250	59.0	65.5	71.3
300	77.6	86.1	93.8
400	119.4	132.5	144.4
500	166.9	185.2	201.8
600	219.4	243.4	265.3

Note: Effective depth, h must be $\geq 3 \times$ anchor size, d_b in order to achieve tabled shear capacities.
All data relevant for Non-cracked concrete

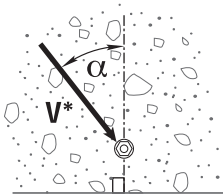

Load direction effect, conc. edge shear, X_{vd}

Table 4b Concrete compressive strength effect, concrete edge shear, X_{vc}

f_c (MPa)	20	25	32	40	50
X_{vc}	0.79	0.88	1.00	1.12	1.25

Table 4c Load direction effect, concrete edge shear, X_{vd}

Angle, α°	0	10	20	30	40	50	60	70	80	90 - 180
X_{vd}	1.00	1.04	1.16	1.32	1.50	1.66	1.80	1.91	1.98	2.00

Table 4d Anchor spacing effect, concrete edge shear, X_{va}

Note: For single anchor designs, $X_{va} = 1.0$

Edge distance, e (mm)	35	50	70	80	100	150	200	250	300	400	500	600
Anchor spacing, a (mm)												
50	0.79	0.70	0.64	0.63	0.60	0.57	0.55	0.54	0.53	0.53	0.52	0.52
75	0.93	0.80	0.71	0.69	0.65	0.60	0.58	0.56	0.55	0.54	0.53	0.53
100	1.00	0.90	0.79	0.75	0.70	0.63	0.60	0.58	0.57	0.55	0.54	0.53
125		1.00	0.86	0.81	0.75	0.67	0.63	0.60	0.58	0.56	0.55	0.54
150			0.93	0.88	0.80	0.70	0.65	0.62	0.60	0.58	0.56	0.55
175			1.00	0.94	0.85	0.73	0.68	0.64	0.62	0.59	0.57	0.56
200				1.00	0.90	0.77	0.70	0.66	0.63	0.60	0.58	0.57
225					0.95	0.80	0.73	0.68	0.65	0.61	0.59	0.58
250					1.00	0.83	0.75	0.70	0.67	0.63	0.60	0.58
275						0.87	0.78	0.72	0.68	0.64	0.61	0.59
300						0.90	0.80	0.74	0.70	0.65	0.62	0.60
400						1.00	0.90	0.82	0.77	0.70	0.66	0.63
500							1.00	0.90	0.83	0.75	0.70	0.67
750								1.00	1.00	0.88	0.80	0.75
1000										1.00	0.90	0.83
1250											1.00	0.92
1500												1.00

Boa™ Coil

STRENGTH LIMIT STATE DESIGN

Table 4e Multiple anchors effect, concrete edge shear, X_{vn}

Note: For single anchor designs, $X_{vn} = 1.0$

Anchor spacing / Edge distance, a / e	0.20	0.40	0.60	0.80	1.00	1.20	1.40	1.60	1.80	2.00	2.25	2.50
Number of anchors, n												
2	1.00	1.00	1.00	1.00	1.00	1.00	1.00	1.00	1.00	1.00	1.00	1.00
3	0.72	0.76	0.80	0.83	0.86	0.88	0.91	0.93	0.95	0.96	0.98	1.00
4	0.57	0.64	0.69	0.74	0.79	0.82	0.86	0.89	0.92	0.94	0.97	1.00
5	0.49	0.57	0.63	0.69	0.74	0.79	0.83	0.87	0.90	0.93	0.97	1.00
6	0.43	0.52	0.59	0.66	0.71	0.77	0.81	0.85	0.89	0.93	0.96	1.00
7	0.39	0.48	0.56	0.63	0.69	0.75	0.80	0.84	0.88	0.92	0.96	1.00
8	0.36	0.46	0.54	0.61	0.68	0.74	0.79	0.84	0.88	0.92	0.96	1.00
9	0.34	0.44	0.52	0.60	0.67	0.73	0.78	0.83	0.87	0.91	0.96	1.00
10	0.32	0.42	0.51	0.59	0.66	0.72	0.77	0.82	0.87	0.91	0.96	1.00
15	0.26	0.37	0.47	0.55	0.63	0.70	0.76	0.81	0.86	0.90	0.95	1.00
20	0.23	0.35	0.45	0.54	0.61	0.68	0.75	0.80	0.85	0.90	0.95	1.00

Table 4f Anchor at a corner effect, concrete edge shear, X_{vs}

Note: For $e_1/e_2 > 1.25$, $X_{vs} = 1.0$

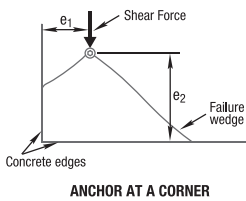

Edge distance, e_2 (mm)	25	30	35	50	60	75	125	200	300	400	600	900
Edge distance, e_1 (mm)												
25	0.86	0.77	0.70	0.58	0.53	0.49	0.41	0.37	0.35	0.34	0.32	0.32
30	0.97	0.86	0.78	0.64	0.58	0.52	0.43	0.38	0.36	0.34	0.33	0.32
35	1.00	0.95	0.86	0.69	0.63	0.56	0.46	0.40	0.37	0.35	0.33	0.32
50	1.00	1.00	1.00	0.86	0.77	0.67	0.52	0.44	0.39	0.37	0.35	0.33
60	1.00	1.00	1.00	0.97	0.86	0.75	0.57	0.47	0.41	0.38	0.36	0.34
75	1.00	1.00	1.00	1.00	1.00	0.86	0.64	0.51	0.44	0.41	0.37	0.35
125	1.00	1.00	1.00	1.00	1.00	1.00	0.86	0.65	0.53	0.48	0.42	0.38
200	1.00	1.00	1.00	1.00	1.00	1.00	1.00	0.86	0.67	0.58	0.49	0.42
300	1.00	1.00	1.00	1.00	1.00	1.00	1.00	1.00	0.86	0.72	0.58	0.49
400	1.00	1.00	1.00	1.00	1.00	1.00	1.00	1.00	1.00	0.86	0.67	0.55
500	1.00	1.00	1.00	1.00	1.00	1.00	1.00	1.00	1.00	1.00	0.77	0.61
600	1.00	1.00	1.00	1.00	1.00	1.00	1.00	1.00	1.00	1.00	0.86	0.67
900	1.00	1.00	1.00	1.00	1.00	1.00	1.00	1.00	1.00	1.00	1.00	0.86

Checkpoint 4

Design reduced ultimate concrete edge shear capacity, ϕV_{urc}

$$\phi V_{urc} = \phi V_{uc} * X_{vc} * X_{vd} * X_{va} * X_{vn} * X_{vs}$$

STEP 5

Verify anchor shear capacity - per anchor

Table 5a Reduced characteristic ultimate steel shear capacity, ϕV_{us} (kN), $\phi_v = 0.8$

Anchor size, d_b (mm)	13	16	19
$h \geq 6 \times d_b$	32.0	55.3	80.7
$h \geq 5 \times d_b$	26.7	46.1	67.2
$h \geq 4 \times d_b$	21.3	36.9	53.8
$h \geq 3 \times d_b$	16.0	27.7	40.3

Boa™ Coil

STRENGTH LIMIT STATE DESIGN

Checkpoint 5

Design reduced ultimate shear capacity, ϕV_{ur}

$\phi V_{ur} = \text{minimum of } \phi V_{urc}, \phi V_{us}$

Check $V^* / \phi V_{ur} \leq 1$,

if not satisfied return to step 1

Shear performance conversion table

Performance Required	Concrete Shear Performance		Steel Shear Performance	
	Notation	Concrete Shear Capacity	Notation	Carbon Steel Shear Capacity
Strength Limit State	ϕV_{uc}	MULTIPLY $\phi V_{uc} \times 1.00$	ϕV_{us}	MULTIPLY $\phi V_{us} \times 1.00$
Working Load Limit	V_{ac}	MULTIPLY $\phi V_{uc} \times 0.55$	V_{as}	MULTIPLY $\phi V_{us} \times 0.50$
Cyclic Loading	V_{yc}	MULTIPLY $\phi V_{uc} \times 0.55$	V_{ys}	MULTIPLY $\phi V_{us} \times 0.50$
Fire Resistance	$V_{Rk,c,fit}$	Refer to Fire Rated Anchors	$V_{Rk,s,fit}$	Refer to Fire Rated Anchors
Seismic	$V_{Rd,c,sis}^0$	Refer to Seismic Anchors	$V_{Rd,s,sis}^0$	Refer to Seismic Anchors

NOTE: Design Shear Capacity is the minimum of Concrete Shear and Steel Shear Capacities

STEP 6

Combined loading and specification

Checkpoint 6

Check

$N^* / \phi N_{ur} + V^* / \phi V_{ur} \leq 1.2$,

if not satisfied return to step 1

Specify

Ramset Boa™ Coil Anchor,
(Anchor Size) ((Part Number)).
Maximum fixed thickness to be (t) mm.

Example

Ramset Boa™ Coil Anchor,
16 mm (BAC10125).
Maximum fixed thickness to be 14 mm.
To be installed in accordance to Ramset™
Installation Instructions.

TruBolt™ Xtrem™

STUD ANCHORS - NON-CRACKED & CRACKED CONCRETE

[Back to index](#)

GENERAL INFORMATION

Performance Related	Material Specification	Installation Related

Product

A seismic certified heavy duty, torque controlled expansion anchor for permanent anchoring into concrete. Certified for seismic C1 & C2 applications.

Compliance

European Technical Assessment (option 1) - ETA-21/0973

Design according to:

- AS5216 (formerly TS101)
- AS1170.4 - Earthquake Actions
- EN1992-4 (formerly ETAG001 Annex C, E & TR045)
- NZS3101 (A3) Section 17 - Seismic Design C1 & C2

For optimised performance data, please use Ramset iExpert Anchoring Software.

Benefits, Advantages and Features

- Highest level of European approval for mechanical expansion anchors
- Approved for all directions (floor, wall, overhead)
- Maximum Tensile & Shear capacities in cracked concrete
- Zinc Plating 5µm and Stainless Steel A4 316
- Anchor diameters M10 to M20

Suitable for structural loads:

- "True to size" through fixture anchor

Improved security:

- Torque induced pull down closes gaps and induces preload.

Resistant to cyclic loading:

- Heavy duty sleeve with pull-down of fixture
- Anti rotation expansion sleeve

Fast installation:

- Anchor diameter equals hole diameter
- Shallow embedment depths
- Through fixing eliminates marking out and repositioning of fixtures.



Principal Applications

- Anchoring into cracked & non cracked concrete
- Structural Steel columns & beams
- Road barrier hold down
- Bridge refurbishment
- Road & Rail tunnel construction
- Wall Plates
- Safety barriers
- Stadium seating
- Pallet racking
- Shallow embedment depths from 50mm
- Intended working life of the anchor of 50 years

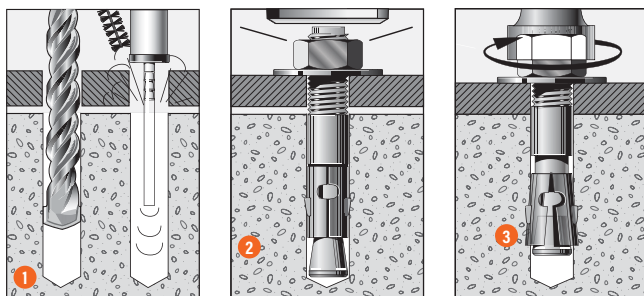

- Drill hole to correct diameter and depth. Important: Use Ramset™ Dustless Drilling System to ensure holes are clean. Alternatively, clean thoroughly with brush and remove debris by way of vacuum or hand pump, compressed air etc.
- Insert the TruBolt™ Xtrem™ through the fixture and drive with a hammer until washer contacts the fixture.
- Tighten the TruBolt™ Xtrem™ nut with a torque wrench to specified assembly torque.

TruBolt™ Xtrem™

STUD ANCHORS - NON-CRACKED & CRACKED CONCRETE

Mechanical Anchoring

Installation and Working Load Limit performance details

Anchor size, d _b (mm)	Drilled hole diameter, d _h (mm)	Fixture hole diameter, d _f (mm)	Anchor effective depth, h (mm)	Depth of drill hole, h ₁ (mm)	Tightening torque, T _r (Nm)	Concrete substrate thickness, b _m (mm)***	Non-Cracked Concrete Tension, φN _{ur} (kN)*		
							Concrete Compressive Strength, f _c		
							20 MPa	32 MPa	40 MPa
M10	10	12	60	75	45	120	13.3	14.4	15.3
M12	12	14	70	90	60**	140	19.1	21.6	23.0
M16	16	18	85	110	110	170	25.7	30.6	33.8
M20	20	22	100	130	160	200	32.7	40.0	46.2

NOTE: M20 not available in SS

* Data is based on optimal dimensions, anchor spacing = 3*h, edge distance = 1.5*h

** Reduced characteristic ultimate concrete tensile capacity = φN_{ur} where φ = 0.67 and N_{ur} = Characteristic ultimate concrete tensile capacity.

For conversion to Working Load Limit MULTIPLY φN_{ur} x 0.50

† For Cracked concrete performance, please use the simplified limit state design process to verify capacity.

** Tightening Torque, T_r taken as 75Nm for stainless steel TruBolt Xtrem.

***Note: For performance based on smaller concrete substrate thickness, refer to iExpert Anchor Software or Ramset™ Engineer.

DESCRIPTION AND PART NUMBERS

Anchor size, d _b (mm)	Drilled hole diameter, d _h (mm)	Effective Length, L _e (mm)	Maximum Fixture Thickness, t _{fix,max} (mm)	ETA Designation Number		Part Number	
						Zn	S/S
M10	10	50	10	10x70/10	1	-	T10070SSX #
		65	5	10x85/25-5	D	T10085X	-
		75	15	10x95/35-15	2	-	T10095SSX
		80	20	10x100/40-20	F	T10100X	-
		85	25	10x105/45-25	3	-	T10105SSX
		100	40	10x120/60-40	G	T10120X	-
		110	50	10x130/70-50	4	-	T10130SSX
M12	12	70	20	12x95/20	1	-	T12095SSX #
		80	10	12x105/30-10	F	T12105X	-
		85	15	12x110/35-15	2	-	T12110SSX
		90	20	12x115/40-20	G	T12115X	-
		95	25	12x120/45-25	3	-	T12120SSX
		110	40	12x135/60-40	I	T12135X	-
		115	45	12x140/65-45	4	-	T12140SSX
M16	16	85	20	16x120/20	1	-	T16120SSX #
		105	20	16x140/40-20	2	-	T16140SSX
		110	25	16x145/45-25	I	T16145X	-
		135	50	16x170/70-50	K	T16170X	-
M20	20	130	30	20x170/30	K	T20170X	-
		160	60	20x200/60	M	T20200X	-

#Note: Effective depth not addressed in performance tables. Refer to iExpert for performance details.

ENGINEERING PROPERTIES

Description	Zn		S/S	
	Material	Protection	Material	Protection
Bolt	Carbon Steel	M10 - M20: Zinc electroplated (>5µm) EN ISO 4042:2018	M10-M16 Stainless Steel A4	M10-M16 Stainless Steel A4, EN 10088.3:2014 + ,coated
Clip	M10 - M20 Carbon Steel	M10 - M20: Zinc electroplated (>5µm) EN ISO 4042:2018	M10-M16 Stainless Steel A4	M10-M16 Stainless Steel A4, EN 10088.3:2014
Washer	M10 - M20 EN ISO 7092:200	M10 - M20: Zinc electroplated (>5µm) EN ISO 4042:2018	M10 - M16 EN ISO 7092:200	M10-M16 Stainless Steel A4
Nut	Steel, Strenth class 8, ISO 898-2:2012	M10: Zinc electroplated (>5µm) EN ISO 4042:2018	M10-M16 Stainless Steel A4-80	M10-M16 Stainless Steel A4-80, EN ISO 3506-2:2019, coated
		M12 - M20: Zinc electroplated (>5µm) EN ISO 4042:2018		

TruBolt™ Xtrem™

STRENGTH LIMIT STATE DESIGN

STEP 1

Select anchor to be evaluated

Table 1a Indicative combined loading - interaction diagram

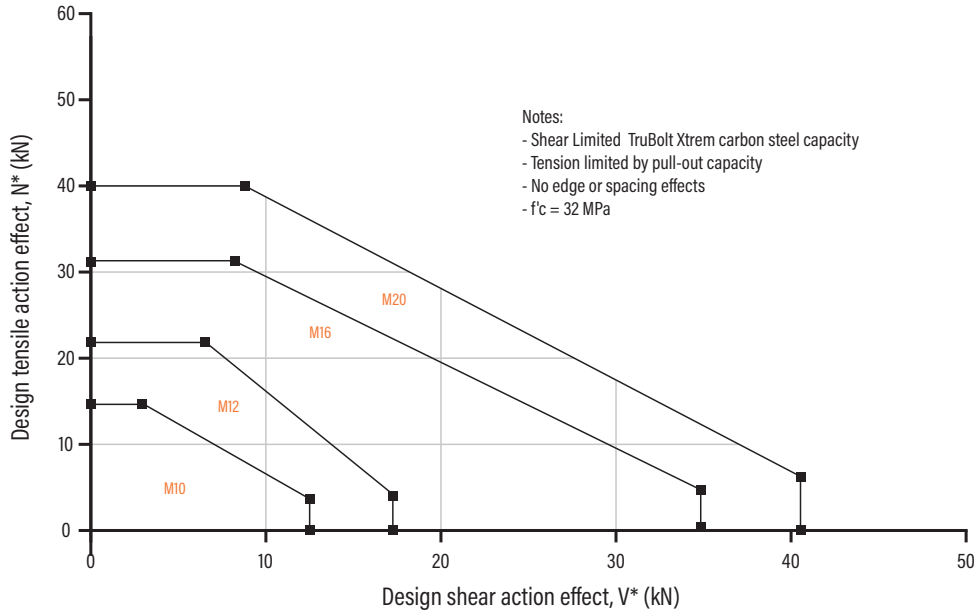

Table 1b-1 Cracked Concrete absolute minimum edge distance and anchor spacing values, e_m and a_m (mm) for TruBolt Xtrem Carbon Steel and Stainless Steel

Anchor size, d_b	M10	M12	M16	M20
Effective depth, h (mm)	60	70	85	100
Min. member thickness (mm)*	120	140	170	200
Min. Anchor spacing - a_m	55	60	90	100
For - e_m	70**	100	100	120
Min. Edge Distance - e_m	55	60	80	100
For - a_m	90	145	110	130

*Note: For performance based on smaller concrete substrate thickness, refer to iExpert Anchor Software or Ramset™ Engineer.

** for TruBolt Xtreme SS - $e_m = 65$

Table 1b-2 Un-cracked Concrete absolute minimum edge distance and anchor spacing values, e_m and a_m (mm) for TruBolt Xtrem Carbon Steel and Stainless Steel

Anchor size, d_b	M10	M12	M16	M20
Effective depth, h (mm)	60	70	85	100
Min. member thickness (mm)*	120	140	170	200
Min. Anchor spacing - a_m	55	60	90	130
For - e_m	70**	100	105	120
Min. Edge Distance - e_m	60	60	90	100
For - a_m	120	145	140	160

*Note: For performance based on smaller concrete substrate thickness, refer to iExpert Anchor Software or Ramset™ Engineer.

** for TruBolt Xtreme SS - $e_m = 65$

Step 1c Calculate anchor effective depth, h (mm)

Refer to "Description and Part Numbers" table on the previous page.

Effective depth, h (mm)

$$h = L_e - t$$

t = total thickness of material(s) being fixed

Checkpoint 1

Anchor size determined, absolute minimal compliance achieved, effective depth (h) calculated.

TruBolt™ Xtrem™

STRENGTH LIMIT STATE DESIGN

Mechanical Anchoring

STEP 2

Verify tensile capacity - per anchor

Table 2a-1 Reduced characteristic ultimate concrete tensile capacity, ϕN_{uc} (kN), $\phi_c = 1/1.5 = 0.67$, $f'_c = 32$ MPa

Anchor size, d_b	M10	M12	M16	M20
Drill hole dia, d_h (mm)	10	12	16	20
Effective depth, h (mm)				
60	19.2			
70		24.2		
85			32.5	
100				41.4

For optimised performance data, please use Ramset iExpert Anchoring Software.

Table 2a-2 Cracked Concrete effect, tension, X_{ncr}

Anchor Size d_b	M10	M12	M16	M20
X_{ncr}	0.70			

If Concrete is Non-Cracked then $X_{ncr} = 1.0$

Table 2b Concrete compressive strength effect, tension, X_{nc} and Pull-out, X_{npc}

Anchor size, d_b	Tension X_{nc}	M10	M12	M16	M20
		Pull-out X_{npc}			
f'_c (MPa)					
20	0.79	0.93	0.93	0.87	0.82
25	0.88	0.96	0.96	0.93	0.9
32	1.00	1.00	1.00	1.00	1.00
40	1.12	1.06	1.06	1.10	1.16
50	1.25	1.10	1.10	1.18	1.27

Table 2c - Concrete Edge distance effect, tension, X_{ne}

Anchor size, d_b	M10	M12	M16	M20
Edge distance, e (mm)				
55	0.70			
60	0.75	0.67		
70	0.83	0.75		
80	0.91	0.82	0.72	
90	1	0.89	0.77	
100		0.96	0.83	0.75
110		1	0.89	0.80
120			0.95	0.85
130			1	0.9
150				1

Table 2d - Concrete anchor spacing effect, tension, X_{na}

Anchor size, d_b	M10	M12	M16	M20
Anchor spacing, a (mm)				
55	0.65			
60	0.66	0.64		
70	0.69	0.66		
80	0.72	0.69		
90	0.75	0.71	0.67	
100	0.77	0.73	0.69	0.66
125	0.84	0.79	0.74	0.70
150	0.91	0.85	0.79	0.75
180	1	0.92	0.85	0.80
210		1	0.91	0.85
255			1	0.92
300				1

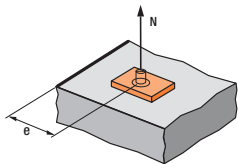

$$X_{ne} = 0.25 + 0.5 * (e/h)$$

Where $e_m \leq e \leq e_c$

$$e_c = 1.5 * h$$

Note: Tabled values are based on the nominal effective depth, h shown in the installation details. For other values of X_{ncr} please use equation shown above.

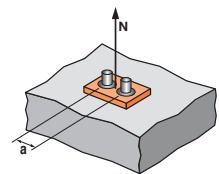

$$X_{na} = 0.5 + a / (6 * h)$$

Where $a_m \leq a \leq a_c$

$$a_c = 3 * h$$

Note: Tabled values are based on the nominal effective depth, h shown in the installation details. For other values X_{na} , please use equation shown above.

Checkpoint 2

Design reduced ultimate concrete tensile capacity, ϕN_{urc}

$$\phi N_{urc} = \phi N_{uc} * X_{ncr} * X_{nc} * X_{ne} * X_{na}$$

TruBolt™ Xtrem™

STRENGTH LIMIT STATE DESIGN

STEP 3

Verify anchor tensile capacity - per anchor

Table 3a Reduced characteristic ultimate steel tensile capacity, ϕN_{us} (kN)

Anchor size, d_b	M10	M12	M16	M20
TruBolt Xtrem™ - Carbon Steel	19.5	25.5	43.1	66.1
TruBolt Xtrem™ - Stainless Steel	20.5	29.7	43.2	-

Carbon Steel:

$$\phi_n = 1/1.5 = 0.67$$

Stainless Steel:

$$\phi_n = 1/1.76 = 0.57 \text{ (M10-M12)}$$

$$\phi_n = 1/2.11 = 0.47 \text{ (M16)}$$

Table 3b-1 Reduced characteristic ultimate pull-out capacity, ϕN_{up} (kN) $\phi_p = 1/1.5 = 0.67$, $f'c = 32 \text{ MPa}$

Anchor size, d_b	M10	M12	M16	M20
Drill hole dia, d_h (mm)	15	18	24	28
Effective depth, h (mm)				
60	14.4			
70		21.6		
85			30.6	
100				40.0

Table 3b-2 Cracked Concrete effect, pull-out, X_{pcr}

Anchor size, d_b	M10	M12	M16	M20
X_{pcr}	0.44	0.53	0.50	0.61

For Non-Cracked Concrete $X_{pcr} = 1$

Checkpoint 3a

Design reduced ultimate pull-out capacity, ϕN_{urp}

$$\phi N_{urp} = \phi N_{up} * X_{pcr} * X_{npc}$$

Checkpoint 3b

Design reduced ultimate tensile capacity, ϕN_{ur}

$$\phi N_{ur} = \text{minimum of } \phi N_{urc}, \phi N_{urp}, \phi N_{us}$$

Check $N^*/\phi N_{ur} \leq 1$,

if not satisfied return to step 1

TruBolt™ Xtrem™

STRENGTH LIMIT STATE DESIGN

Mechanical Anchoring

STEP 4

Verify concrete edge shear capacity - per anchor

Table 4a-1 Reduced characteristic ultimate concrete edge shear capacity, ϕV_{uc} (kN), $\phi = 1/1.5 = 0.67$, $f'_c = 32$ MPa

Anchor size, d_b	M10	M12	M16	M20
Effective depth, h (mm)	60	70	85	100
Edge distance, e_m				
60	7.0	7.5		
90			13.9	
100				17.1

For optimised performance data, please use Ramset iExpert Anchoring Software.

Table 4a-2 Cracked Concrete effect, shear, X_{vcr}

Anchor Size, d_b	M10	M12	M16	M20
X_{vcr}	0.70			

For Non-cracked concrete $X_{vcr} = 1.0$

Table 4b Concrete compressive strength effect, concrete edge shear, X_{vc}

f'_c (MPa)	20	25	32	40	50
X_{vc}	0.79	0.88	1.00	1.12	1.25

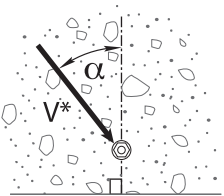

Load direction effect, conc. edge shear, X_{vd}

Table 4c - Concrete load direction effect, concrete edge shear, X_{vd}

Angle, α°	0-55	60	70	80	90-180
X_{vd}	1.0	1.1	1.2	1.5	2.0

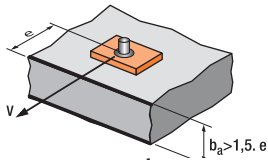

$$X_{ve} = e/e_m * \sqrt{e/e_m}$$

Table 4d - Concrete anchor spacing and edge distance effect, concrete edge shear, X_{ve}

For single anchor fastening X_{ve}

e/e_m	1.0	1.2	1.4	1.6	1.8	2.0	2.2	2.4	2.6	2.8	3.0	3.2
X_{ve}	1.00	1.31	1.66	2.02	2.41	2.83	3.26	3.72	4.19	4.69	5.20	5.72

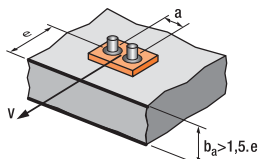

$$X_{ve} = \frac{3 * e + a}{6 * e_m} * \sqrt{e/e_m}$$

For 2 anchors fastening X_{ve}

e/e_m	1.0	1.2	1.4	1.6	1.8	2.0	2.2	2.4	2.6	2.8	3.0	3.2
a/e_m												
1.0	0.67	0.84	1.03	1.22	1.43	1.65	1.88	2.12	2.36	2.62	2.89	3.16
1.5	0.75	0.93	1.12	1.33	1.54	1.77	2.00	2.25	2.50	2.76	3.03	3.31
2.0	0.83	1.02	1.22	1.43	1.65	1.89	2.12	2.38	2.63	2.90	3.18	3.46
2.5	0.92	1.11	1.32	1.54	1.77	2.00	2.25	2.50	2.77	3.04	3.32	3.61
3.0	1.00	1.20	1.42	1.64	1.88	2.12	2.37	2.63	2.90	3.18	3.46	3.76
3.5		1.30	1.52	1.75	1.99	2.24	2.50	2.76	3.04	3.32	3.61	3.91
4.0			1.62	1.86	2.10	2.36	2.62	2.89	3.17	3.46	3.75	4.05
4.5				1.96	2.21	2.47	2.74	3.02	3.31	3.60	3.90	4.20
5.0					2.33	2.59	2.87	3.15	3.44	3.74	4.04	4.35
5.5						2.71	2.99	3.28	3.71	4.02	4.33	4.65
6.0							2.83	3.11	3.41	3.71	4.02	4.33

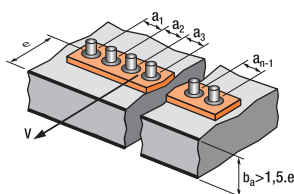

For 3 anchors fastening and more X_{ve}

$$X_{ve} = \frac{3 * e + a_1 + a_2 + a_3 + \dots + a_{n-1}}{3 * n * e_m} * \sqrt{e/e_m}$$

TruBolt™ Xtrem™

STRENGTH LIMIT STATE DESIGN

Table 4e Reduced characteristic ultimate concrete pryout capacity, ϕV_{ucp} (kN), $\phi = 1/1.5 = 0.67$, $f'_c = 32$ MPa

Anchor size, d_b	M10	M12	M16	M20
Effective depth, h (mm)	60	70	85	100
60	38.4			
70		48.4		
85			65.0	
100				82.8

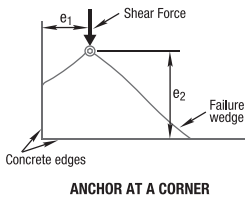

Table 4f Anchor at a corner effect, concrete edge shear, X_{VS}

Note: For $e_1/e_2 > 1.25$, $X_{VS} = 1.0$

Edge distance, e_2 (mm)	25	30	35	50	60	75	125	200	300	400	600	900
Edge distance, e_1 (mm)												
25	0.86	0.77	0.70	0.58	0.53	0.49	0.41	0.37	0.35	0.34	0.32	0.32
30	0.97	0.86	0.78	0.64	0.58	0.52	0.43	0.38	0.36	0.34	0.33	0.32
35	1.00	0.95	0.86	0.69	0.63	0.56	0.46	0.40	0.37	0.35	0.33	0.32
50	1.00	1.00	1.00	0.86	0.77	0.67	0.52	0.44	0.39	0.37	0.35	0.33
60	1.00	1.00	1.00	0.97	0.86	0.75	0.57	0.47	0.41	0.38	0.36	0.34
75	1.00	1.00	1.00	1.00	1.00	0.86	0.64	0.51	0.44	0.41	0.37	0.35
125	1.00	1.00	1.00	1.00	1.00	1.00	0.86	0.65	0.53	0.48	0.42	0.38
200	1.00	1.00	1.00	1.00	1.00	1.00	1.00	0.86	0.67	0.58	0.49	0.42
300	1.00	1.00	1.00	1.00	1.00	1.00	1.00	1.00	0.86	0.72	0.58	0.49
400	1.00	1.00	1.00	1.00	1.00	1.00	1.00	1.00	1.00	0.86	0.67	0.55
500	1.00	1.00	1.00	1.00	1.00	1.00	1.00	1.00	1.00	1.00	0.77	0.61
600	1.00	1.00	1.00	1.00	1.00	1.00	1.00	1.00	1.00	1.00	0.86	0.67
900	1.00	1.00	1.00	1.00	1.00	1.00	1.00	1.00	1.00	1.00	1.00	0.86

Checkpoint **4a**

Design reduced ultimate concrete edge shear capacity, ϕV_{urc}

$$\phi V_{urc} = \phi V_{uc} * X_{vcr} * X_{vc} * X_{vd} * X_{ve} * X_{vs}$$

Checkpoint **4b**

Design reduced ultimate concrete pryout capacity, ϕV_{urcp}

$$\phi V_{urcp} = \phi V_{ucp} * X_{ncr} * X_{nc} * X_{ne} * X_{na}$$

STEP **5**

Verify anchor shear capacity - per anchor

Table 5a Reduced characteristic ultimate steel shear capacity, ϕV_{usr} (kN)

Anchor size, d_b	M10	M12	M16	M20
TruBolt Xtrem™ - Carbon Steel	12.6	18.1	35.4	40.7
TruBolt Xtrem™ - Stainless Steel	12.7	19.2	18.1	-

Carbon Steel:

$$\phi_s = 1/1.27 = 0.79 \text{ (M10-M16)}$$

$$\phi_s = 1/1.5 = 0.67 \text{ (M20)}$$

Stainless Steel:

$$\phi_s = 1/1.47 = 0.68 \text{ (M10-M12)}$$

$$\phi_s = 1/1.75 = 0.57 \text{ (M16)}$$

Checkpoint **5**

Design reduced ultimate shear capacity, ϕV_{ur}

$$\phi V_{ur} = \text{minimum of } \phi V_{urc}, \phi V_{urcp}, \phi V_{us}$$

Check $V^*/\phi V_{ur} \leq 1$,

if not satisfied return to step 1

TruBolt™ Xtrem™

STRENGTH LIMIT STATE DESIGN

Mechanical Anchoring

STEP 6 Combined Loading

Checkpoint 6

Check
 $N^*/\phi N_{ur} + V^*/\phi V_{ur} \leq 1.2,$
if not satisfied return to step 1

Specify
Ramset™ TruBolt™ Xtrem™ Anchor,
(Anchor Size) (Part Number)
Maximum fixed thickness to be (t) mm.

Example
Ramset™ TruBolt™ Xtrem™ Anchor, M12 T12115X.
Maximum fixed thickness to be 20mm. To be installed in
accordance to Ramset™ Installation Instructions..

Use Ramset™ iExpert Anchor Software for optimised calculation or where a greater range of anchor layout detail is needed.

TruBolt™

STUD ANCHORS - NON-CRACKED CONCRETE

GENERAL INFORMATION

Performance Related	Material Specification	Installation Related

Product

The Trubolt Anchor is a Heavy duty, torque setting expansion anchor.

Benefits, Advantages and Features

Maximum shear capacity for hole size:

- Stud diameter equals hole diameter.

Fast installation:

- Through fixing eliminates marking out and repositioning of fixtures.

High clamp load:

- Stud design ensures pull-down on fixture.

Outstanding exterior durability:

- 42 micron hot dip galvanised coating.

Superior strength:

- Cold forged steel construction.

Ramset Design Method:

- Uses technical data validated from testing in ANZ concrete substrates



Principal Applications

- Structural beams and columns
- Bottom plate and batten fixing
- Formwork support
- Installing signs, handrails, balustrades and gates
- Safety barriers

Installation

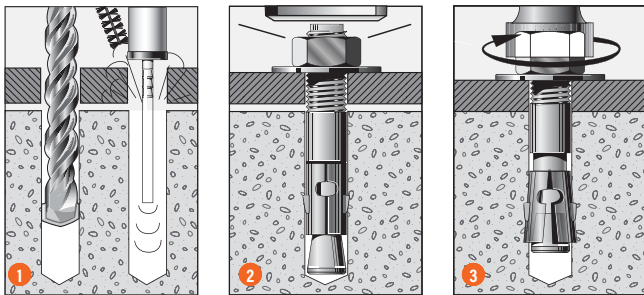

1. Drill hole to correct diameter and depth. Important: Use **Ramset™** Dustless Drilling System to ensure holes are clean. Alternatively, clean clean thoroughly with brush and remove debris by way of vacuum or hand pump, compressed air etc.
2. Insert the **Trubolt™** through the fixture and drive with a hammer until washer contacts the fixture.
3. Tighten the **Trubolt™** nut with a torque wrench to specified assembly torque.

TruBolt™

STUD ANCHORS - NON-CRACKED CONCRETE

Mechanical Anchoring

Installation and performance details

Anchor Size, d_b (mm)	Installation details				Optimum dimensions*		Reduced Characteristic Capacity			
	Drilled Hole diam., d_h (mm)	Fixture hole diameter, d_f (mm)	Anchor effective depth, h (mm)	Tightening torque, T , (Nm)	Edge distance, e_c (mm)	Anchor spacing, a_c (mm)	Steel	Concrete		
							Shear, ϕV_{us} (kN)	Tension, ϕN_{uc} (kN)**		
								Concrete compressive strength, f'_c		
20MPa	25MPa	32MPa								
M10	10	12	40	35	60	120	13.5	6.7	7.5	8.5
M12	12	14	48	50	75	150	17.1	8.8	9.9	11.2
M16	16	18	64	155	100	200	28.8	13.6	15.2	17.2
M20	20	24	80	355	120	240	54.7	19.0	21.3	24.0

* Note: For shear loads acting towards an edge or where these optimum dimensions are not achievable, please use the simplified strength limit state design process to verify capacity.

**Note: Reduced characteristic ultimate concrete tensile capacity = ϕN_{uc} , where $\phi = 0.60$ and N_{uc} = Characteristic ultimate concrete tensile capacity.

For conversion to Working Load Limit MULTIPLY $\phi N_{uc} \times 0.55$

DESCRIPTION AND PART NUMBERS

Anchor size, d_b (mm)	Drilled hole diameter, d_h (mm)	Effective length, L_e (mm)	Part No.
M10	10	67	T10090GH
M12	12	58	T12080GH
		71	T12100GH
		111	T12140GH
		151	T12180GH
M16	16	70	T16110GH
		85	T16125GH
		110	T16150GH
		135	T16175GH
M20	20	95	T20140GH
		115	T20160GH
		170	T20215GH

Effective depth, h (mm)

$h = L_e - t$

t = total thickness of material(s) being fixed

Substrate thickness, b_m (mm)

$b_m = 2 \times h$

Drilled hole depth, h_1 (mm)

$h_1 = h + (2 \times d_h)$

h = Effective depth

ENGINEERING PROPERTIES

Anchor size d_b	Stress area thread section A_s (mm ²)	Minimum diameter reduced section d_m (mm)	Threaded Section		Reduced Section		Section Modulus Z (mm ³)
			Yield Strength, f_y (Mpa)	UTS, f_u (Mpa)	Yield Strength, f_y (Mpa)	UTS, f_u (Mpa)	
M10	58.0	7.6	380	470	480	600	62.3
M12	84.3	8.9	330	410	450	560	109.2
M16	157.0	12.1	290	370	400	500	277.5
M20	245.0	16.1	360	450	360	450	540.9

TruBolt™

STUD ANCHORS - NON-CRACKED CONCRETE

STEP 1 Select anchor to be evaluated

Table 1a Indicative combined loading - interaction diagram

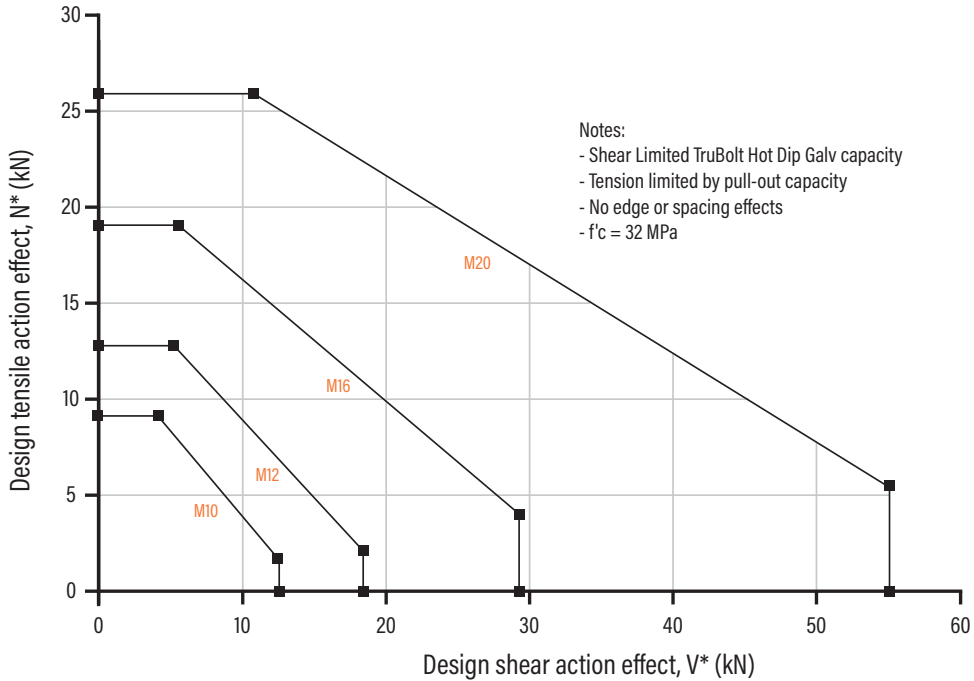

Table 1b Uncracked Concrete absolute minimum edge distance and anchor spacing values, e_m and a_m (mm) for TruBolt Hot Dip Gal

Anchor size, d_b	M10	M12	M16	M20
Min. Anchor Spacing - a_m	40	45	50	60
Min. Anchor Spacing - e_m	60	65	75	95

Step 1c Calculate anchor effective depth, h (mm)

Refer to "Description and Part Numbers" table on the previous page.

Effective depth, h (mm)
 $h = L_e - t$
 t = total thickness of material(s) being fixed

Checkpoint 1 Anchor size determined, absolute minimal compliance achieved, effective depth (h) calculated.

TruBolt™

STUD ANCHORS - NON-CRACKED CONCRETE

Mechanical Anchoring

STEP 2 Verify concrete tensile capacity - per anchor

Table 2a Reduced characteristic ultimate concrete tensile capacity, ϕN_{uc} (kN), $\phi_c = 0.6$, $f'_c = 32$ MPa

Anchor Size, d_b	M10	M12	M16	M20
Drilled Hole Dia, d_h (mm)	10	12	16	20
Effective Depth, h (mm)				
40	8.5			
50	11.9	11.9		
65	17.6	17.6	17.6	
80	24.0	24.0	24.0	24.0
95	31.0	31.0	31.0	31.0
110	38.7	38.7	38.7	38.7
125		46.8	46.8	46.8
145		58.5	58.5	58.5
160			67.8	67.8
180				81.0

All data relevant for Non-cracked concrete

Note: Effective depth, h must be $\geq 4 \times$ drilled hole diameter, d_h for anchor to achieve tabled shear capacities.

Table 2b Concrete compressive strength effect, tension, X_{nc}

f'_c (Mpa)	20	25	32	40	50
X_{nc}	0.79	0.88	1.00	1.00	1.00

Table 2c Edge distance effect, tension, X_{ne}

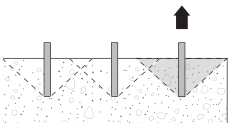

Edge distance, e (mm)	60	70	80	100	125	150	175	200	230
Effective depth, h (mm)									
40	1.00	1.00							
50	0.86	0.95	1.00						
65	0.73	0.80	0.87	1.00					
80	0.65	0.71	0.77	0.88	1.00				
95	0.59	0.64	0.69	0.79	0.91	1.00			
110	0.55	0.60	0.64	0.72	0.83	0.94	1.00		
125	0.52	0.56	0.60	0.67	0.77	0.86	0.95	1.00	
145	0.49	0.53	0.56	0.62	0.70	0.78	0.86	0.94	1.00
160	0.48	0.50	0.53	0.59	0.66	0.74	0.81	0.88	0.97

Table 2d Anchor spacing effect, end of a row, tension, X_{nae}

Note: For single anchor designs, $X_{nae} = 1.0$



Edge distance, a (mm)	40	50	60	80	100	125	150	175	200	250	300	350	400
Effective depth, h (mm)													
40	0.67	0.71	0.75	0.83	0.92	1.00							
50	0.63	0.67	0.70	0.77	0.83	0.92	1.00	1.00					
65	0.60	0.63	0.65	0.71	0.76	0.82	0.88	0.95	1.00				
80	0.58	0.60	0.63	0.67	0.71	0.76	0.81	0.86	0.92	1.00			
95	0.57	0.59	0.61	0.64	0.68	0.72	0.76	0.81	0.85	0.94	1.00		
110	0.56	0.58	0.59	0.62	0.65	0.69	0.73	0.77	0.80	0.88	0.95	1.00	
125	0.55	0.57	0.58	0.61	0.63	0.67	0.70	0.73	0.77	0.83	0.90	0.97	1.00
145	0.55	0.56	0.57	0.59	0.61	0.64	0.67	0.70	0.73	0.79	0.84	0.90	0.96
160	0.54	0.55	0.56	0.58	0.60	0.63	0.66	0.68	0.71	0.76	0.81	0.86	0.92

TruBolt™

STUD ANCHORS - NON-CRACKED CONCRETE

Table 2e Anchor spacing effect, internal to a row, tension, X_{nai}

Note: For single anchor designs, $X_{nai} = 1.0$

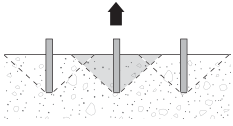

Edge distance, a (mm)	40	50	60	80	100	125	150	175	200	250	300	350	400
Effective depth, h (mm)													
40	0.33	0.42	0.50	0.67	0.83	1.00							
50	0.27	0.33	0.40	0.53	0.67	0.83	1.00	1.00					
65	0.21	0.26	0.31	0.41	0.51	0.64	0.77	0.90	1.00				
80	0.17	0.21	0.25	0.33	0.42	0.52	0.63	0.73	0.83	1.00			
95	0.14	0.18	0.21	0.28	0.35	0.44	0.53	0.61	0.70	0.88	1.00		
110	0.12	0.15	0.18	0.24	0.30	0.38	0.45	0.53	0.61	0.76	0.91	1.00	
125	0.11	0.13	0.16	0.21	0.27	0.33	0.40	0.47	0.53	0.67	0.80	0.93	1.00
145	0.09	0.11	0.14	0.18	0.23	0.29	0.34	0.40	0.46	0.57	0.69	0.80	0.92
160		0.10	0.13	0.17	0.21	0.26	0.31	0.36	0.42	0.52	0.63	0.73	0.83

Checkpoint 2

Design reduced ultimate concrete tensile capacity, ϕN_{urc}

$$\phi N_{urc} = \phi N_{uc} * X_{nc} * X_{ne} * (X_{nae} \text{ or } X_{nai})$$

STEP 3

Verify Concrete Tensile Resistance - per anchor

Table 3a Reduced characteristic ultimate steel tensile capacity, ϕN_{us} (kN), $\phi_n = 0.8$

Anchor size, d_b	M10	M12	M16	M20
Trubolt - Hot Dip Galvanized	21.8	27.8	45.5	72.5

Table 3b Reduced characteristic ultimate pull-out capacity*, ϕN_{up} (kN), $\phi_p = 0.65$, $f'c = 32$ MPa

Anchor size, d_b	M10	M12	M16	M20
Hole Diameter, d_h (mm)	10	12	16	20
Effective depth, h (mm)				
40	9.2			
50		12.9		
65			19.0	
80				26.0

*Note: Reduced characteristic ultimate Pull-through capacity is not influenced by reduced anchor spacing or edge distance

Checkpoint 3a

Design reduced ultimate pull-out capacity, ϕN_{urp}

$$\phi N_{urp} = \phi N_{up} * X_{nc}$$

Checkpoint 3b

Design reduced ultimate tensile capacity, ϕN_{ur}

$\phi N_{ur} = \text{minimum of } \phi N_{urc}, \phi N_{urp}, \phi N_{us}$

Check $N^*/\phi N_{ur} \leq 1$,

if not satisfied return to step 1

TruBolt™

STUD ANCHORS - NON-CRACKED CONCRETE

Mechanical Anchoring

Tensile performance conversion table

Performance Required	Concrete Tensile Performance		Pull - Through Performance		Steel Tensile Performance	
	Notation	Concrete Tension Capacity	Notation	Pull - Through Tension Capacity	Notation	Carbon Steel Tension Capacity
Strength Limit State	ϕN_{urc}	MULTIPLY $\phi N_{urc} \times 1.00$	ϕN_{up}	MULTIPLY $\phi N_{up} \times 1.00$	ϕN_{us}	MULTIPLY $\phi N_{us} \times 1.00$
Working Load Limit	N_{ac}	MULTIPLY $\phi N_{urc} \times 0.55$	N_{sp}	MULTIPLY $\phi N_{up} \times 0.51$	N_{as}	MULTIPLY $\phi N_{us} \times 0.56$
Cyclic Loading	N_{yc}	MULTIPLY $\phi N_{urc} \times 0.19$	N_{yp}	MULTIPLY $\phi N_{up} \times 0.18$	N_{ys}	MULTIPLY $\phi N_{us} \times 0.19$
Fire Resistance	$N_{Rk,c,ft}$	Refer to Fire Resistance Section	$N_{Rk,p,ft}$	Refer to Fire Resistance Section	$N_{Rk,s,ft}$	Refer to Fire Resistance Section
Seismic	$N_{rd,c,sis}^0$	Refer to Seismic Section	$N_{rd,p,sis}^0$	Refer to Seismic Section	$N_{rd,s,sis}^0$	Refer to Seismic Section

NOTE: Design Tensile Capacity is the minimum of Concrete Tension and Steel Tension Capacities

STEP 4 Verify concrete shear capacity - per anchor

Table 4a Reduced characteristic ultimate concrete edge shear capacity, ϕV_{uc} (kN), $\phi = 0.6$, $f'_c = 32$ MPa

Anchor size, d_b	M10	M12	M16	M20
Hole Diameter, d_h (mm)	10	12	16	20
Edge distance, e (mm)				
60	6.1			
75	8.5	9.3	10.8	
100	13.1	14.3	16.6	18.5
150	24.1	26.4	30.4	34.0
200	37.0	40.6	46.9	52.4
250	51.8	56.7	65.5	73.2
300	68.0	74.5	86.1	96.2
350	85.7	93.9	108.5	121.3
450		136.9	158.1	176.8
600				272.2

Note: Effective depth, h must be $\geq 4 \times$ drilled hole diameter, d_h for anchor to achieve tabled shear capacities.

Table 4b Concrete compressive strength effect, concrete edge shear, X_{vc}

f'_c (MPa)	20	25	32	40	50
X_{vc}	0.79	0.88	1.00	1.12	1.25

Table 4c - Concrete load direction effect, concrete edge shear, X_{vd}

Angle, α°	0-55	60	70	80	90-180
X_{vd}	1.0	1.1	1.2	1.5	2.0

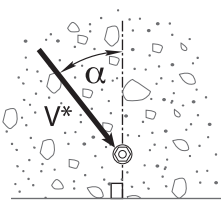

Load direction effect, conc. edge shear, X_{vd}

TruBolt™

STUD ANCHORS - NON-CRACKED CONCRETE

Table 4d Anchor spacing effect, concrete edge shear, X_{va}

Note: For single anchor designs, $X_{va} = 1.0$

Edge distance, e (mm)	60	75	100	150	200	250	300	350	450	600	850
Anchor spacing, a (mm)											
40	0.63	0.61	0.58	0.55	0.54	0.53	0.53	0.52	0.52	0.51	0.51
60	0.70	0.66	0.62	0.58	0.56	0.55	0.54	0.53	0.53	0.52	0.51
80	0.77	0.71	0.66	0.61	0.58	0.56	0.55	0.55	0.54	0.53	0.52
100	0.83	0.77	0.70	0.63	0.60	0.58	0.57	0.56	0.54	0.53	0.52
125	0.92	0.83	0.75	0.67	0.63	0.60	0.58	0.57	0.56	0.54	0.53
150	1.00	0.90	0.80	0.70	0.65	0.62	0.60	0.59	0.57	0.55	0.54
200		1.00	0.90	0.77	0.70	0.66	0.63	0.61	0.59	0.57	0.55
250			1.00	0.83	0.75	0.70	0.67	0.64	0.61	0.58	0.56
300				0.90	0.80	0.74	0.70	0.67	0.63	0.60	0.57
400				1.00	0.90	0.82	0.77	0.73	0.68	0.63	0.59
500					1.00	0.90	0.83	0.79	0.72	0.67	0.62
600						0.98	0.90	0.84	0.77	0.70	0.64
800						1.00	1.00	0.96	0.86	0.77	0.69
1000								1.00	0.94	0.83	0.74
1500									1.00	1.00	0.85
2000											0.97

Table 4e Multiple anchors effect, concrete edge shear, X_{vn}

Note: For single anchor designs, $X_{vn} = 1.0$

Anchor spacing / Edge distance, a/e	0.20	0.40	0.60	0.80	1.00	1.20	1.40	1.60	1.80	2.00	2.25	2.50
Number of Anchors, n												
2	1.00	1.00	1.00	1.00	1.00	1.00	1.00	1.00	1.00	1.00	1.00	1.00
3	0.72	0.76	0.80	0.83	0.86	0.88	0.91	0.93	0.95	0.96	0.98	1.00
4	0.57	0.64	0.69	0.74	0.79	0.82	0.86	0.89	0.92	0.94	0.97	1.00
5	0.49	0.57	0.63	0.69	0.74	0.79	0.83	0.87	0.90	0.93	0.97	1.00
6	0.43	0.52	0.59	0.66	0.71	0.77	0.81	0.85	0.89	0.93	0.96	1.00
7	0.39	0.48	0.56	0.63	0.69	0.75	0.80	0.84	0.88	0.92	0.96	1.00
8	0.36	0.46	0.54	0.61	0.68	0.74	0.79	0.84	0.88	0.92	0.96	1.00
9	0.34	0.44	0.52	0.60	0.67	0.73	0.78	0.83	0.87	0.91	0.96	1.00
10	0.32	0.42	0.51	0.59	0.66	0.72	0.77	0.82	0.87	0.91	0.96	1.00
15	0.26	0.37	0.47	0.55	0.63	0.70	0.76	0.81	0.86	0.90	0.95	1.00
20	0.23	0.35	0.45	0.54	0.61	0.68	0.75	0.80	0.85	0.90	0.95	1.00

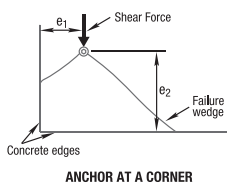

Table 4f Anchor at a corner effect, concrete edge shear, X_{vs}

Note: For $e_1/e_2 > 1.25$, $X_{vs} = 1.0$

Edge distance, e_2 (mm)	25	30	35	50	60	75	125	200	300	400	600	900
Edge distance, e_1 (mm)												
25	0.86	0.77	0.70	0.58	0.53	0.49	0.41	0.37	0.35	0.34	0.32	0.32
30	0.97	0.86	0.78	0.64	0.58	0.52	0.43	0.38	0.36	0.34	0.33	0.32
35	1.00	0.95	0.86	0.69	0.63	0.56	0.46	0.40	0.37	0.35	0.33	0.32
50	1.00	1.00	1.00	0.86	0.77	0.67	0.52	0.44	0.39	0.37	0.35	0.33
60	1.00	1.00	1.00	0.97	0.86	0.75	0.57	0.47	0.41	0.38	0.36	0.34
75	1.00	1.00	1.00	1.00	1.00	0.86	0.64	0.51	0.44	0.41	0.37	0.35
125	1.00	1.00	1.00	1.00	1.00	1.00	0.86	0.65	0.53	0.48	0.42	0.38
200	1.00	1.00	1.00	1.00	1.00	1.00	1.00	0.86	0.67	0.58	0.49	0.42
300	1.00	1.00	1.00	1.00	1.00	1.00	1.00	1.00	0.86	0.72	0.58	0.49
400	1.00	1.00	1.00	1.00	1.00	1.00	1.00	1.00	1.00	0.86	0.67	0.55
500	1.00	1.00	1.00	1.00	1.00	1.00	1.00	1.00	1.00	1.00	0.77	0.61
600	1.00	1.00	1.00	1.00	1.00	1.00	1.00	1.00	1.00	1.00	0.86	0.67
900	1.00	1.00	1.00	1.00	1.00	1.00	1.00	1.00	1.00	1.00	1.00	0.86

Checkpoint

4

Design reduced ultimate concrete pryout capacity, ϕV_{urcp}

$$\phi V_{urc} = \phi V_{uc} * X_{vc} * X_{vd} * X_{va} * X_{vn} * X_{vs}$$

TruBolt™

STUD ANCHORS - NON-CRACKED CONCRETE

Mechanical Anchoring

STEP 5 Verify anchor shear capacity - per anchor

Table 5a Reduced characteristic ultimate steel shear capacity, ϕV_{usr} (kN), $\phi_v = 0.8$

Anchor size, d_b	M10	M12	M16	M20
Trubolt - Hot Dip Galvanized	13.5	171	28.8	54.7

Checkpoint 5

Design reduced ultimate shear capacity, ϕV_{ur}
 $\phi V_{ur} = \text{minimum of } \phi V_{urc}, \phi V_{us}$
 Check $V^*/\phi V_{ur} \leq 1$, if not satisfied return to step 1

Shear performance conversion table

Performance Required	Concrete Shear Performance		Steel Shear Performance	
	Notation	Concrete Shear Capacity	Notation	Carbon Steel Shear Capacity
Strength Limit State	ϕV_{uc}	MULTIPLY $\phi V_{uc} \times 1.00$	ϕV_{us}	MULTIPLY $\phi V_{us} \times 1.00$
Working Load Limit	V_{ac}	MULTIPLY $\phi V_{uc} \times 0.55$	V_{as}	MULTIPLY $\phi V_{us} \times 0.50$
Cyclic Loading	V_{yc}	MULTIPLY $\phi V_{uc} \times 0.55$	V_{ys}	MULTIPLY $\phi V_{us} \times 0.50$
Fire Resistance	$V_{Rk,c,ft}$	Refer to Fire Resistance Section	$V_{Rk,s,ft}$	Refer to Fire Resistance Section
Seismic	$V_{Rd,c,sis}^0$	Refer to Seismic Section	$V_{Rd,s,sis}^0$	Refer to Seismic Section

NOTE: Design Shear Capacity is the minimum of Concrete Shear and Steel Shear Capacities.

STEP 6 Combined loading and specification

Checkpoint 6

Check
 $N^*/\phi N_{ur} + V^*/\phi V_{ur} \leq 1.2$,
 if not satisfied return to step 1

Specify
 Ramset™ Trubolt™ Hot Dip Galv. Anchor,
 (Anchor Size) (Part Number)
 Maximum fixed thickness to be (t) mm.

Example
 Ramset™ Trubolt™ Hot Dip Galv. Anchor, M12 T12140GH.
 Maximum fixed thickness to be 20mm. To be installed in
 accordance to Ramset™ Installation Instructions.

AnkaScrew™ Xtrem™

SCREW IN ANCHORS - NON-CRACKED & CRACKED CONCRETE

[Back to index](#)

GENERAL INFORMATION

Performance Related	Material	Installation Related

Product

A seismic certified heavy duty screw-in anchor for permanent anchoring into concrete. Certified for seismic C1 & C2 applications.



Compliance

European Technical Assessment (option1) - ETA-20/0731

Design According to:

- Stud diameter equals hole diameter.
- AS5216 (formerly TS101)
- AS1170.4 - Earthquake Actions
- EN1992-4 (formerly ETAG001 Annex C, E & TR045)
- NZS3101 (A3) Section 17 - Seismic Design C1 & C2

Use Ramset™ iExpert Anchor Software for optimised calculation or where a greater range of anchor layout detail is needed

Benefits, Advantages and Features

Fire tested to TR020

- Fire rated performance up to 120 minutes
- Highest level of European assessment for mechanical screw-in anchors
- Approved for all directions (floor, wall, overhead)
- Maximum Tensile & Shear capacities in cracked concrete
- Zinc Plating 5µm
- Anchor diameters 6mm to 12mm

Fast and easy to use:

- Install, simply screws into hole.
- Remove, leaving an empty hole.

Close to edge and for close anchor spacing:

- Does not expand and burst concrete.



Principal Applications

- Anchoring into cracked & non cracked concrete
- Steel framing
- Mechanical services
- Pallet racking
- Safety barriers
- Conveyors
- Hand rails
- Bottom plates

Installation

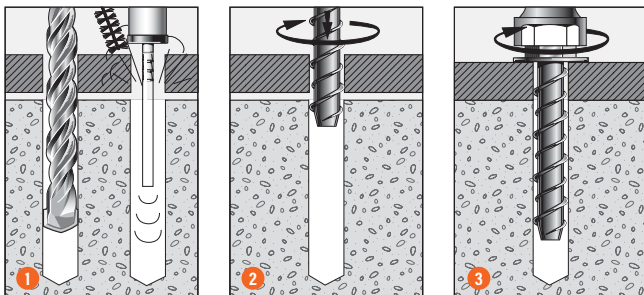

1. Drill hole to correct diameter and depth. Important: Use Ramset™ Dustless Drilling System to ensure holes are clean. Alternatively, clean clean thoroughly with brush and remove debris by way of vacuum or hand pump, compressed air etc.
2. Using a socket wrench, screw the AnkaScrew™ Xtrem™ into the hole using slight pressure until the self tapping action starts.
3. Tighten the AnkaScrew™ Xtrem™ until flush with fixture.
If resistance is experienced when tightening, unscrew anchor one turn and re-tighten. Ensure not to over tighten. Refer to tightening torque for limitations.

Mechanical Anchoring - AnkaScrew™ Xtrem™

AnkaScrew™ Xtrem™

SCREW IN ANCHORS - NON-CRACKED & CRACKED CONCRETE

Installation and performance details

Anchor size, d _b (mm)	Drilled hole diameter, d _h (mm)	Fixture hole diameter, d _f (mm)	Anchor effective depth, h (mm)	Depth of drill hole, h _i (mm)	Tightening torque, T _r (Nm)	Concrete substrate thickness, b _m (mm) ***	Non-Cracked Concrete Tension, φN _{ur} (kN) **		
							Concrete Compressive Strength, f _c		
							20 MPa	30 MPa	40 MPa
6	6	8	31	45	10	80	2.7	3.3	3.8
			44	60		90	6.0	7.3	8.5
8	8	12	35	55	20	80	5.0	6.1	7.1
			43	65		90	8.0	9.8	11.3
			52	75		105	10.7	13.0	15.0
10	10	14	43	65	40	90	8.0	9.8	11.3
			60	85		120	13.3	16.3	18.8
			68	95		136	17.3	21.1	24.4
12	12	16	50	75	60	100	10.7	13.0	15.0
			67	95		134	18.0	22.8	25.4
			80	110		160	23.5	29.7	33.2

Data is based on optimal dimensions, anchor spacing = 3*h, edge distance = 1.5*h

For shear loads acting towards an edge or where optimum dimensions are not achievable, please use the simplified strength limit state design process to verify capacity

** Reduced characteristic ultimate tensile capacity = φN_{ur}, where φ = 0.67 and N_{ur} is based on characteristic ultimate pull-out tensile capacity for sizes 6-10 and concrete tensile capacity for size 12 where h≥67.

For conversion to Working Load Limit MULTIPLY φN_{ur} x 0.50

For Cracked Concrete performance, please use the simplified strength limit state design process to verify capacity.

***Note: For performance based on smaller concrete substrate thickness, refer to iExpert Anchor Software or Ramset™ Engineer.

DESCRIPTION AND PART NUMBERS

Anchor size, d _b (mm)	Drilled hole diameter, d _h (mm)	Effective Length, L _e (mm)	Maximum Fixture Thickness, t _{fix,max} (mm)	AnkaScrew™ Xtrem™ Description	Part Number
6	6	41	10	6mmx50mm zinc	AS06050X
		71	40	6mmx80mm zinc	AS06080X
8	8	50	15	8mmx60mm zinc	AS08060X
		67	32	8mmx80mm zinc	AS08080X
10	10	48	5	10mmx60mm zinc	AS10060X
		88	45	10mmx100mm zinc	AS10100X
12	12	65	15	12mmx80mm zinc	AS12080X
		95	45	12mmx110mm zinc	AS12110X
		135	85	12mmx150mm zinc	AS12150X

Effective depth, h (mm)

$$h = L_e - t$$

t = total thickness of material(s) being fixed

ENGINEERING PROPERTIES

Anchor size, d _b (mm)	Minimum cross sectional diameter (mm)	Stress area, A _s (mm ²)	Yield strength, f _y (MPa)	UTS, F _u (Mpa)
6	5.1	20.4	560	700
8	7.1	39.6	560	700
10	9.1	65.0	560	700
12	11.1	96.8	560	700

AnkaScrew Xtrem™

STRENGTH LIMIT STATE DESIGN

STEP 1

Select anchor to be evaluated

Table 1a Indicative combined loading - interaction diagram

Table 1b Absolute minimum edge distance and anchor spacing values, e_m and a_m (mm)

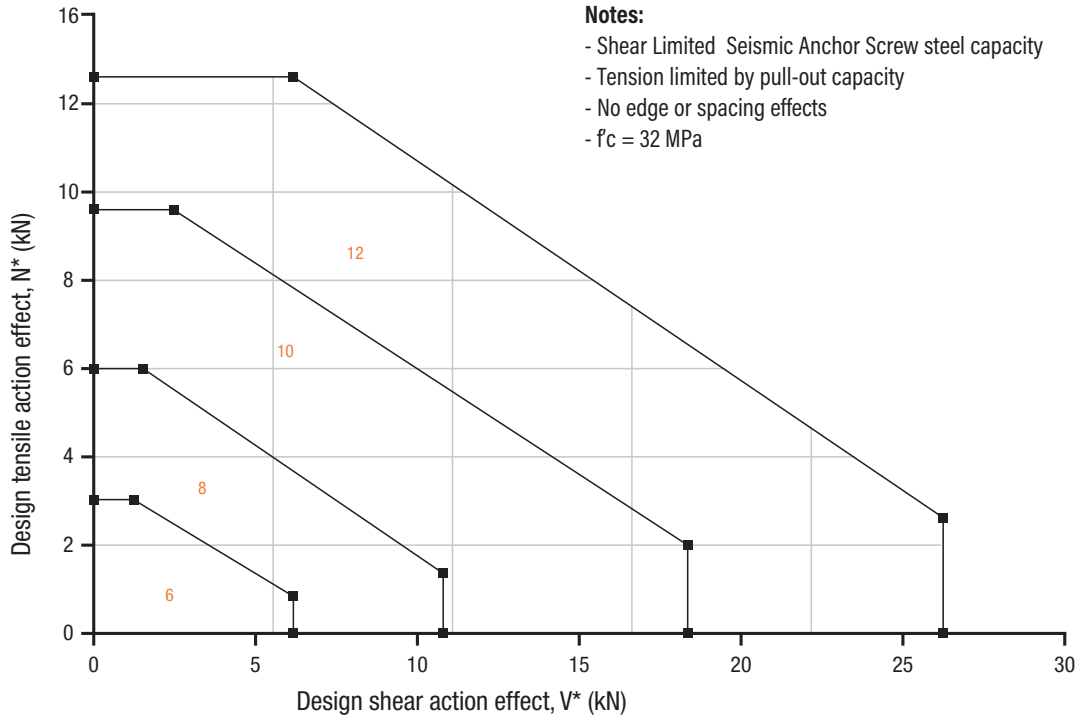

Anchor size, d_b	6		8			10			12		
Effective depth, h (mm)	31	44	35	43	52	43	60	68	50	67	80
*Min. member thickness (mm)	80	90	80	90	105	90	120	136	100	134	160
Min. Anchor Spacing - a_m	40	40	40	50	50	50	50	50	50	50	70
Min. Edge Distance - e_m	40	40	40	50	50	50	50	50	50	50	70

*Note: For calculations based on smaller member thickness, refer to iExpert Anchor Software or Ramset™ Engineer.

Step 1c Calculate anchor effective depth, h (mm)

Refer to "Description and Part Numbers" table on the previous page.

Effective depth, h (mm)

$$h = L_e - t$$

t = total thickness of material(s) being fixed

Checkpoint 1

Anchor size determined, absolute minima compliance achieved, effective depth (h) calculated.

AnkaScrew™ Xtrem™

STRENGTH LIMIT STATE DESIGN

Mechanical Anchoring - AnkaScrew™ Xtrem™

STEP 2

Verify Non-cracked & cracked concrete tensile resistance - per anchor

Table 2a - Reduced characteristic ultimate concrete tensile capacity, ϕN_{uc} (kN), $\phi_c = 1/1.5 = 0.67$, $f'_c = 32$ MPa

Anchor size, d_b	6	8	10	12
Drill hole dia, d_h (mm)	6	8	10	12
Effective depth, h (mm)				
31	7.2			
35		8.6		
43		11.7	11.7	
44	12.1			
50				14.7
52		15.6		
60			19.3	
67				22.8
68			23.3	
80				29.7

For optimised performance data, please use Ramset iExpert Anchoring Software.

Table 2a-2-Cracked Concrete effect, tension, X_{ncr}

Anchor size, d_b	6	8	10	12
X_{ncr}	0.70			

Table 2b - Concrete compressive strength effect, tension, X_{nc} and Pull-out, X_{npc}

f'_c (MPa)	20	25	32	40	50
Tension X_{nc}	0.79	0.88	1.00	1.12	1.25
Pull-out X_{npc}	0.82	0.92	1.00	1.16	1.30

Table 2c - Concrete Edge distance effect, tension, X_{ne}

Anchor size, d_b	6	8	10	12
Effective depth, h (mm)	44	52	68	80
Edge distance, e (mm)				
40	0.70			
50	0.82	0.73	0.62	
55	0.88	0.78	0.65	
70	1	0.92	0.76	0.69
75		0.97	0.80	0.72
80		1	0.84	0.75
85			0.88	0.78
90			0.91	0.81
100			0.99	0.88
105			1	0.91
110				0.94
115				0.97
120				1

Table 2d - Concrete anchor spacing effect, tension, X_{na}

Anchor size, d_b	6	8	10	12
Effective depth, h (mm)	44	52	68	80
Edge distance, a (mm)				
40	0.65			
50	0.69	0.66	0.62	
60	0.73	0.69	0.65	
70	0.77	0.72	0.67	
80	0.80	0.76	0.70	
90	0.84	0.79	0.72	
100	0.88	0.82	0.75	0.71
110	0.92	0.85	0.77	0.73
120	0.95	0.88	0.79	0.75
130	0.99	0.92	0.82	0.77
140	1	0.95	0.84	0.79
150		0.98	0.87	0.81
160		1	0.89	0.83
170			0.92	0.85
180			0.94	0.88
190			0.97	0.90
200			0.99	0.92
250			1	1

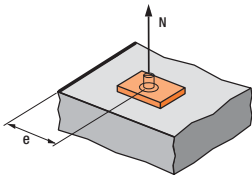

$$X_{ne} = 0.25 + 0.5 \cdot (e/h)$$

Where $e_m \leq e \leq e_c$

$$e_c = 1.5 \cdot h$$

Note: Tabled values are based on the nominal effective depth, h shown in the installation details. For other values of X_{ne} , please use equation shown above.

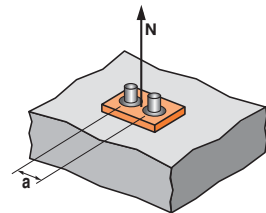

$$X_{na} = 0.5 + a/(6 \cdot h)$$

Where $a_m \leq a \leq a_c$

$$a_c = 3 \cdot h$$

Note: Tabled values are based on the nominal effective depth, h shown in the installation details. For other values of X_{na} , please use equation shown above.

Checkpoint 2

Design reduced ultimate cracked concrete tensile capacity ϕN_{urc}

$$\phi N_{urc} = \phi N_{uc} \cdot X_{ncr} \cdot X_{nc} \cdot X_{ne} \cdot X_{na}$$

AnkaScrew™ Xtrem™

STRENGTH LIMIT STATE DESIGN

STEP 3

Verify Non-cracked & cracked concrete tensile resistance - per anchor

Table 3a Reduced characteristic ultimate steel tensile capacity, ϕN_{usr} (kN) where $\phi_n = (1/1.5) = 0.67$

Anchor size, db	6	8	10	12
AnkaScrew™ Xtrem™	9.3	18.0	30.0	44.7

Table 3b-1 - Reduced characteristic ultimate pull-out capacity, ϕN_{up} (kN) $\phi_p = 0.67, f'c = 32$ MPa

Anchor size, d _b	6	8	10	12
Drill hole dia, d _h (mm)	6	8	10	12
Effective depth, h (mm)				
31	3.3			
35		6.1		
43		9.8	9.8	
44	7.3			
50				13.0
52		13.0		
60			16.3	
67				N/A
68			21.1	
80				N/A

Table 3b-2 Cracked Concrete effect, pull-out, X_{pcr}

Anchor size, db	6	8	10	12
Effective Depth, h (mm)	X_{pcr}			
31	0.50			
35		0.67		
43		0.75	0.75	
44	0.44			
50				0.75
52		0.75		
60			N/A*	
67				N/A*
68			N/A*	
80				N/A*

*Governed by cracked concrete tensile capacity

For Non-Cracked concrete $X_{pcr} = 1$

Checkpoint 3a

Design reduced ultimate pull-out capacity, ϕN_{urp}

$$\phi N_{urp} = \phi N_{up} * X_{pcr} * X_{npc}$$

Checkpoint 3b

Design reduced ultimate tensile capacity, ϕN_{ur}

$$\phi N_{ur} = \text{minimum of } \phi N_{urc}, \phi N_{urp}, \phi N_{us}$$

Check $N^*/\phi N_{ur} \leq 1$,

if not satisfied return to step 1

AnkaScrew™ Xtrem™

STRENGTH LIMIT STATE DESIGN

Mechanical Anchoring - AnkaScrew™ Xtrem™

STEP 4

Verify cracked concrete edge shear resistance - per anchor

Table 4a Reduced characteristic ultimate concrete edge shear capacity, ϕV_{uc} (kN), $\phi = 1/1.5 = 0.67$, $f'_c = 32$ MPa

Anchor size, d_b	6		8		
Effective Depth, h (mm)	31	44	35	43	52
Edge distance, e_m					
40	3.4	3.6	3.6	3.7	3.9
50			4.9	5.0	5.2

Anchor size, d_b	10			12		
Effective Depth, h (mm)	43	60	68	50	67	80
Edge distance, e_m						
50	5.2	5.5	5.7	5.5	5.9	6.1
70				8.6	9.1	9.4

For optimised performance data, please use Ramset iExpert Anchoring Software.

Table 4a-2 Cracked Concrete effect, shear, X_{vcr}

Anchor size, d_b	6	8	10	12
X_{vcr}	0.7			

Table 4b Concrete compressive strength effect, concrete edge shear, X_{vc}

f'_c (MPa)	20	25	32	40	50
X_{vc}	0.82	0.90	1.00	1.16	1.27

Table 4c - Concrete load direction effect, concrete edge shear, X_{vd}

Angle, α°	0-55	60	70	80	90-180
X_{vd}	1	1.1	1.2	1.5	2

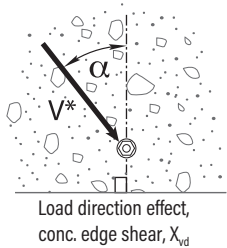
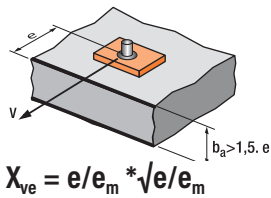

Table 4d - Anchor spacing and edge distance effect, concrete edge shear, X_{ve}

For single anchor fastening X_{ve}

e/e_m	1.0	1.2	1.4	1.6	1.8	2.0	2.2	2.4	2.6	2.8	3.0	3.2
X_{ve}	1.00	1.31	1.66	2.02	2.41	2.83	3.26	3.72	4.19	4.69	5.20	5.72



For 2 anchors fastening X_{ve}

e/e_m	1.0	1.2	1.4	1.6	1.8	2.0	2.2	2.4	2.6	2.8	3.0	3.2
a/e_m												
1.0	0.67	0.84	1.03	1.22	1.43	1.65	1.88	2.12	2.36	2.62	2.89	3.16
1.5	0.75	0.93	1.12	1.33	1.54	1.77	2.00	2.25	2.50	2.76	3.03	3.31
2.0	0.83	1.02	1.22	1.43	1.65	1.89	2.12	2.38	2.63	2.90	3.18	3.46
2.5	0.92	1.11	1.32	1.54	1.77	2.00	2.25	2.50	2.77	3.04	3.32	3.61
3.0	1.00	1.20	1.42	1.64	1.88	2.12	2.37	2.63	2.90	3.18	3.46	3.76
3.5		1.30	1.52	1.75	1.99	2.24	2.50	2.76	3.04	3.32	3.61	3.91
4.0			1.62	1.86	2.10	2.36	2.62	2.89	3.17	3.46	3.75	4.05
4.5				1.96	2.21	2.47	2.74	3.02	3.31	3.60	3.90	4.20
5.0					2.33	2.59	2.87	3.15	3.44	3.74	4.04	4.35
5.5						2.71	2.99	3.28	3.71	4.02	4.33	4.65
6.0							2.83	3.11	3.41	3.71	4.02	4.33

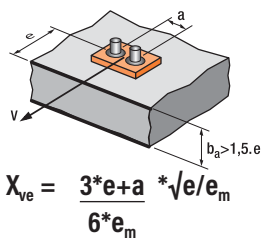

For 3 anchors fastening and more X_{ve}

$$X_{ve} = \frac{3*e + a_1 + a_2 + a_3 + \dots + a_{n-1}}{3*n*e_m} * \sqrt{e/e_m}$$

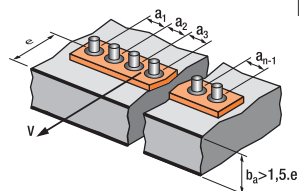

AnkaScrew™ Xtrem™

STRENGTH LIMIT STATE DESIGN

Table 4e Reduced characteristic ultimate concrete pryout capacity, ϕV_{ucp} (kN), $\phi = 1/1.5 = 0.67$, $f'_c = 32$ MPa

Anchor size, db	6	8	10	12
Effective depth, h (mm)				
31	7.2			
35		8.6		
43		11.7	11.7	
44	12.1			
50				14.7
52		15.6		
60			38.6	
67				45.5
68			46.5	
80				59.4

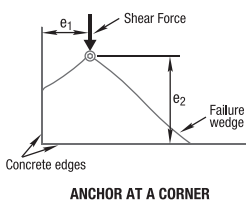

Table 4f Anchor at a corner effect, concrete edge shear, X_{vs}

Note: For $e_1/e_2 > 1.25$, $X_{vs} = 1.0$

Edge distance, e_2 (mm)	25	30	35	50	60	75	125	200	300	400	600	900
Edge distance, e_1 (mm)												
25	0.86	0.77	0.70	0.58	0.53	0.49	0.41	0.37	0.35	0.34	0.32	0.32
30	0.97	0.86	0.78	0.64	0.58	0.52	0.43	0.38	0.36	0.34	0.33	0.32
35	1.00	0.95	0.86	0.69	0.63	0.56	0.46	0.40	0.37	0.35	0.33	0.32
50	1.00	1.00	1.00	0.86	0.77	0.67	0.52	0.44	0.39	0.37	0.35	0.33
60	1.00	1.00	1.00	0.97	0.86	0.75	0.57	0.47	0.41	0.38	0.36	0.34
75	1.00	1.00	1.00	1.00	1.00	0.86	0.64	0.51	0.44	0.41	0.37	0.35
125	1.00	1.00	1.00	1.00	1.00	1.00	0.86	0.65	0.53	0.48	0.42	0.38
200	1.00	1.00	1.00	1.00	1.00	1.00	1.00	0.86	0.67	0.58	0.49	0.42
300	1.00	1.00	1.00	1.00	1.00	1.00	1.00	1.00	0.86	0.72	0.58	0.49
400	1.00	1.00	1.00	1.00	1.00	1.00	1.00	1.00	1.00	0.86	0.67	0.55
500	1.00	1.00	1.00	1.00	1.00	1.00	1.00	1.00	1.00	1.00	0.77	0.61
600	1.00	1.00	1.00	1.00	1.00	1.00	1.00	1.00	1.00	1.00	0.86	0.67
900	1.00	1.00	1.00	1.00	1.00	1.00	1.00	1.00	1.00	1.00	1.00	0.86

Checkpoint **4a**

Design reduced ultimate concrete edge shear capacity, ϕV_{urc}

$$\phi V_{urc} = \phi V_{uc} * X_{vcr} * X_{vc} * X_{vd} * X_{ve} * X_{vs}$$

Checkpoint **4b**

Design reduced ultimate concrete pryout capacity, ϕV_{urcp}

$$\phi V_{urcp} = \phi V_{ucp} * X_{ncr} * X_{nc} * X_{ne} * X_{na}$$

STEP **5**

Verify cracked concrete shear resistance - per anchor

Table 5a Reduced characteristic ultimate steel shear capacity, ϕV_{usr} (kN) where $\phi_v = 0.8$

Anchor size, db	6			8		
	Effective depth, h (mm)	31	44	35	43	52
AnkaScrew™ Xtrem™		5.6	5.6	10.8	10.8	13.6

Anchor size, db	10			12			
	Effective depth, h (mm)	43	60	68	50	67	80
AnkaScrew™ Xtrem™		18.0	27.2	27.2	26.8	33.6	33.6

Checkpoint **5**

Design reduced ultimate tensile capacity, ϕV_{ur}

$$\phi V_{ur} = \text{minimum of } \phi V_{urc}, \phi V_{urcp}, \phi V_{us}$$

Check $V^*/\phi V_{ur} \leq 1$,

if not satisfied return to step 1

AnkaScrew™ Xtrem™

STRENGTH LIMIT STATE DESIGN

Mechanical Anchoring - AnkaScrew™ Xtrem™

STEP 6 Combined Loading

Checkpoint 6

Check
 $N^*/\phi N_{ur} + V^*/\phi V_{ur} \leq 1.2,$
if not satisfied return to step 1

Specify
Ramset™ AnkaScrew™ Xtrem™ Anchor,
(Anchor Size) (Part Number)
Maximum fixed thickness to be (t) mm.

Example
Ramset™ AnkaScrew™ Xtrem™ Anchor, 12mm AS12110X.
Maximum fixed thickness to be 20mm.
To be installed in accordance to Ramset™ Installation Instructions..

Use Ramset™ iExpert Anchor Software for optimised calculation or where a greater range of anchor layout detail is needed.

WERCS AnkaScrew™

SCREW IN ANCHORS - NON-CRACKED CONCRETE

[Back to index](#)

GENERAL INFORMATION

Performance Related	Material Specification	Installation Related

Product

The WERCS AnkaScrew™ Anchor is a medium duty, rotation setting thread forming anchor.

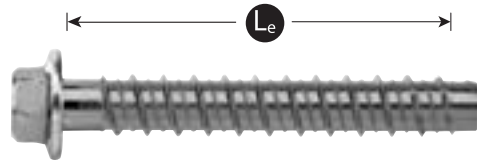

Benefits, Advantages and Features

Fast and easy to install:

- Simply screws into hole.

Fast and easy to remove:

- Screws out leaving an empty hole with no protruding metal parts to grind off.

Close to edge and for close anchor spacing:

- Does not expand and burst concrete.

Ramset Design Method:

- Uses technical data validated from testing in ANZ concrete substrates

Principal Applications

- Pallet racking
- Temporary safety barriers
- Conveyors
- Pipe brackets
- Gate hinges into brickwork
- Temporary hand rails
- Bottom plates

Installation

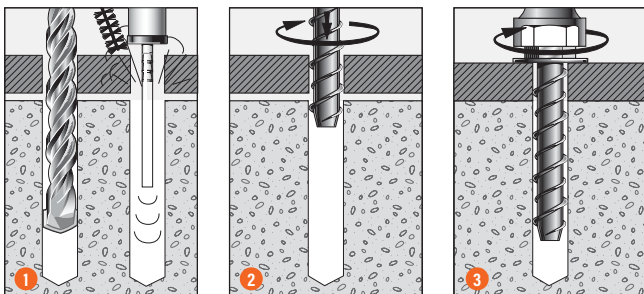

1. Drill hole to correct diameter and depth. Clean thoroughly with brush. Remove debris by way of vacuum or hand pump, compressed air etc.
2. Using a socket wrench, screw the WERCS AnkaScrew™ into the hole using slight pressure until the self tapping action starts.
3. Tighten the WERCS AnkaScrew™ until flush with fixture. If resistance is experienced when tightening, unscrew anchor one turn and re-tighten. Ensure not to over tighten.

WERCS AnkaScrew™

SCREW IN ANCHORS - NON-CRACKED CONCRETE

Mechanical Anchoring

Installation and performance details

Anchor size, d _a (mm)	Installation details				Optimum dimensions*		Reduced Characteristics Capacity			
	Drilled hole diameter, d _h (mm)	Fixture hole diameter, d _f (mm)	Anchor effective depth, h (mm)	Tightening torque, T _r (Nm)	Edge distance, e _c (mm)	Anchor spacing, a _c (mm)	Shear (concrete) φV _{uc} (kN)*** f' _c > 20 MPa	Non-Cracked Concrete Tension, φN _{uc} (kN)**		
								Concrete compressive strength, f' _c		
20 MPa	25 MPa	32 MPa								
5	5	7	25	5	15	15	0.9	2.1	2.3	2.5
6	6	8	30	15	60	35	6.8 #	3.7	4.0	4.3
			37				7.5	4.7	5.0	5.5
			45				7.5	5.8	6.3	6.9
8	8	10	40	40	80	45	12.6 #	5.5	5.9	6.4
			50				13.3	7.3	7.9	8.6
			60				13.3	9.3	10.0	10.9
10	10	12	50	55	100	60	20.7	7.9	8.5	9.3
			62				20.7	10.6	11.5	12.5
			75				20.7	13.9	15.0	16.3
12	12	15	60	80	120	70	25 #	11.2	12.1	13.2
			75				28.4 #	15.5	16.8	18.3
			90				29.8	20.3	21.9	23.9
16	16	19	90	-	160	100	53.0	20.7	24.1	28.4
			105				53.0	25.4	29.5	34.8
			120				53.0	30.3	35.2	41.5

* Note: For shear loads acting towards an edge or where these optimum dimensions are not achievable, please use the simplified strength limit state design process to verify capacity.

**Note: Reduced characteristic ultimate concrete tensile capacity = φN_{uc} where φ = 0.60 and N_{uc} = Characteristic ultimate concrete tensile capacity.

For conversion to Working Load Limit MULTIPLY φN_{uc} x 0.55

*** Note: Values are for shear load direction away from concrete edge - Reduce characteristic ultimate concrete edge shear capacity = φV_{uc} where φ = 0.6 and V_{uc} = Characteristic ultimate concrete edge shear capacity.

Note: Values for shear limited by steel - Reduced characteristic ultimate steel shear capacity = φV_{us} where φ = 0.80 and V_{us} = Characteristic ultimate steel shear capacity.

All data relevant for Non-cracked concrete

DESCRIPTION AND PART NUMBERS

Anchor size, db	Effective length, L _e (mm)	Part No.	
		Zn Hex Head	Gal Hex Head
5	28	AS05030	-
6	44	AS06050W100	AS06050WGM100
	69	AS06075W100	AS06075WGM100
	94	AS06100W100	AS06100WGM100
8	54	AS08060W100	AS08060WGM100
	69	AS08075W100	AS08075WGM100
	94	AS08100W100	AS08100WGM100
10	54	AS10060W50	AS10060WGM50
	69	AS10075W50	AS10075WGM50
	94	AS10100W50	AS10100WGM50
12	69	AS12075W50	AS12075WGM50
	94	AS12100W50	AS12100WGM50
	144	AS12150W20	AS12150WGM20
16	115	AS16115	-
	140	AS16140	-
	160	AS16160	-

Effective depth, h (mm)

$$h = L_e - t,$$

t = total thickness of material(s) being fixed

Substrate thickness, b_m (mm)

$$b_m = \text{greater of: } 1.25 \times h, h + (3 \times d_h)$$

Drilled hole depth, h₁ (mm)

$$h_1 = h + d_h$$

h = Effective depth

ENGINEERING PROPERTIES

Anchor size, d _b (mm)	Stress area, A _s (mm ²)	Yield strength, f _y (MPa)	UTS, f _u (MPa)
5	15.9	600	800
6	22.9	640	800
8	42.4	640	800
10	69.4	640	800
12	84.1	640	800
16	186.3	640	800

WERCS AnkaScrew™

STRENGTH LIMIT STATE DESIGN

STEP 1 Select anchor to be evaluated

Table 1a Indicative combined loading - interaction diagram

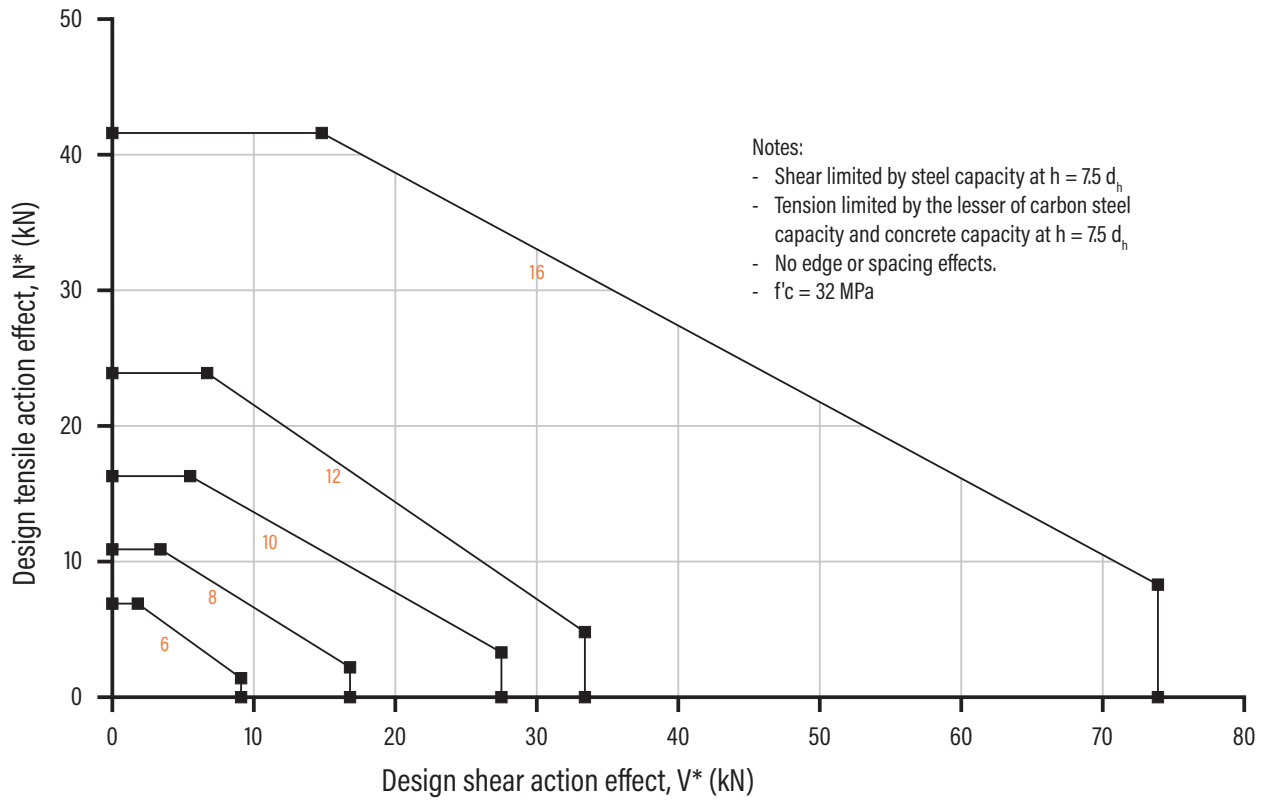

Table 1b Absolute minimum edge distance and anchor spacing values, e_m and a_m (mm)

Anchor Size, d_b (mm)	6	8	10	12	16
e_m, a_m	20	25	30	35	50

Step 1c Calculate anchor effective depth, h (mm)

Refer to "Description and Part Numbers" table on the previous page.

Effective depth, h (mm)

$$h = L_e - t,$$

t = total thickness of material(s) being fixed

Checkpoint 1 Anchor size determined, absolute minima compliance achieved, effective depth (h) calculated.

WERCS AnkaScrew™

STRENGTH LIMIT STATE DESIGN

Mechanical Anchoring

STEP 2 Verify concrete tensile capacity - per anchor

Table 2a Reduced characteristic ultimate concrete tensile capacity, ϕN_{uc} (kN), $\phi_c = 0.6$, $f'_c = 32$ MPa

Anchor Size, d_b	6	8	10	12	16
Drilled Hole Dia, d_h (mm)	6	8	10	12	16
Effective Depth, h (mm)					
30	4.3				
35	5.1				
40	6.0	6.4			
45	6.9	7.5			
50		8.6	9.3		
55		9.8	10.6		
60		10.9	12.0	13.2	
75			16.3	18.3	22.3
90				23.9	28.4
105					34.8
120					41.6

All data relevant for Non-cracked concrete

Table 2b Concrete compressive strength effect, tension, X_{nc}

f'_c (MPa)	20	25	32	40
X_{nc} - Anchor size $d_b = 6-12$	0.85	0.92	1	1.08
X_{nc} - Anchor size $d_b = 16$ only	0.73	0.85	1	1.16

Table 2c Edge distance effect, tension, X_{ne}

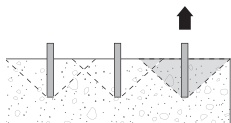

Anchor Size, d_b	6	8	10	12	16
Edge Distance e, (mm)					
20	0.53				
25	0.59	0.52			
30	0.65	0.56	0.51		
35	0.71	0.61	0.55	0.50	
40	0.77	0.65	0.58	0.53	
50	0.88	0.74	0.65	0.59	0.51
60	1.00	0.83	0.72	0.65	0.55
70		0.91	0.79	0.71	0.60
80		1.00	0.86	0.77	0.64
90			0.93	0.83	0.69
100			1.00	0.88	0.73
110				0.94	0.78
120				1.00	0.82
145					0.93
160					1.00

Table 2d Anchor spacing effect, end of a row, tension, X_{nae}

Note: For single anchor designs, $X_{nae} = 1.0$

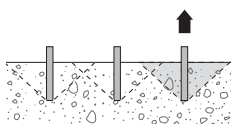

Anchor Size, d_b	6	8	10	12	16
Anchor Spacing a, (mm)					
20	0.78				
25	0.85	0.76			
30	0.92	0.81	0.75		
35	1.00	0.86	0.79	0.78	
40		0.92	0.83	0.81	
45		1.00	0.88	0.81	
50			0.92	0.85	0.76
55			0.96	0.88	0.79
60			1.00	0.92	0.81
70				1.00	0.86
80					0.92
90					0.97
100					1.00

WERCS AnkaScrew™

STRENGTH LIMIT STATE DESIGN

Table 2e Anchor spacing effect, internal to a row, X_{nai}

Note: For single anchor designs, $X_{nai} = 1.0$

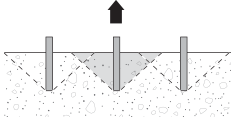

Anchor Size, d_b	6	8	10	12	16
Anchor Spacing a , (mm)					
20	0.56				
25	0.69	0.52			
30	0.83	0.63	0.50		
35	1.00	0.73	0.58	0.49	
40		0.83	0.67	0.56	
45		0.94	0.75	0.63	
50		1.00	0.83	0.69	0.52
55			0.92	0.76	0.57
60			1.00	0.83	0.63
70				1.00	0.73
80					0.83
90					0.94
100					1.00

Checkpoint 2

Design reduced ultimate concrete tensile capacity, ϕN_{urc}

$$\phi N_{urc} = \phi N_{uc} * X_{nc} * X_{ne} * (X_{nae} \text{ or } X_{nai})$$

STEP 3

Verify anchor tensile capacity - per anchor

Table 3a Reduced characteristic ultimate steel tensile capacity, ϕN_{us} (kN), $\phi_n = 0.8$

Anchor size, d_b (mm)	6	8	10	12	16
Heat Treated Carbon Steel	14.6	27.1	44.4	53.8	119.2

Checkpoint 3

Design reduced ultimate tensile capacity, ϕN_{ur}

$$\phi N_{ur} = \text{minimum of } \phi N_{urc}, \phi N_{us}$$

Check $N^* / \phi N_{ur} \leq 1$,

if not satisfied return to step 1

Tensile performance conversion table

Performance Required	Concrete Tensile Performance		Steel Tensile Performance	
	Notation	Concrete Tension Capacity	Notation	Carbon Steel Tension Capacity
Strength Limit State	ϕN_{urc}	MULTIPLY $\phi N_{urc} \times 1.00$	ϕN_{us}	MULTIPLY $\phi N_{us} \times 1.00$
Working Load Limit	N_{ac}	MULTIPLY $\phi N_{urc} \times 0.55$	N_{ss}	MULTIPLY $\phi N_{us} \times 0.56$
Cyclic Loading	N_{yc}	MULTIPLY $\phi N_{urc} \times 0.55$	N_{ys}	MULTIPLY $\phi N_{us} \times 0.56$
Fire Resistance	$N_{Rk,c,fl,t}$	Refer to Fire Rated Anchors	$N_{Rk,s,fl,t}$	Refer to Fire Rated Anchors
Seismic	$N_{Rd,p,sis}^0$	Refer to Seismic Anchors	$N_{Rd,s,sis}$	Refer to Seismic Anchors

NOTE: Design Tensile Capacity is the minimum of Concrete Tension and Steel Tension Capacities

WERCS AnkaScrew™

STRENGTH LIMIT STATE DESIGN

Mechanical Anchoring

STEP 4 Verify concrete shear capacity - per anchor

Table 4a Reduced characteristic ultimate concrete edge shear capacity, ϕV_{uc} (kN), $\phi_q = 0.6$, $f'_c = 32$ MPa

Anchor Size, d_b	6	8	10	12	16
Edge Distance e , (mm)					
20	0.9				
25	1.3	1.5			
30	1.7	1.9	2.2		
35	2.1	2.4	2.7	3.0	
50	3.6	4.1	4.6	5.1	5.9
75	6.6	7.6	8.5	9.3	10.8
100	10.1	11.7	13.1	14.3	16.6
150	18.6	21.5	24.1	26.4	30.4
200	28.7	33.1	37.0	40.6	46.8
250		46.3	51.8	56.7	65.5
300			68.0	74.5	86.1
400				114.8	132.5
500					185.2

Note: Effective depth, h must be $\geq 3.5 \times$ Anchor size, d_b , for anchor to achieve tabled shear capacities
 All data relevant for Non-cracked concrete

Table 4b Concrete compressive strength effect, concrete edge shear, X_{vc}

f'_c (MPa)	20	25	32	40
X_{vc}	0.79	0.88	1.00	1.12

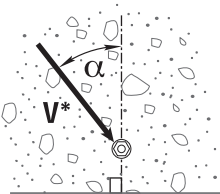

Load direction effect, conc. edge shear, X_{vd}

Table 4c Load direction effect, concrete edge shear, X_{vd}

Angle, α°	0	10	20	30	40	50	60	70	80	90 - 180
X_{vd}	1.00	1.04	1.16	1.32	1.50	1.66	1.80	1.91	1.98	2.00

Table 4d Anchor spacing effect, concrete edge shear, X_{va}

Note: For single anchor designs, $X_{va} = 1.0$

Edge distance, e (mm)	20	25	30	35	50	75	100	150	200	250	300	400	500
Anchor spacing, a (mm)													
20	0.70	0.66	0.63	0.61	0.58	0.55	0.54	0.53	0.52				
25	0.75	0.70	0.67	0.64	0.60	0.57	0.55	0.53	0.53	0.52			
30	0.80	0.74	0.70	0.67	0.62	0.58	0.56	0.54	0.53	0.52	0.52		
35	0.85	0.78	0.73	0.70	0.64	0.59	0.57	0.55	0.54	0.53	0.52	0.52	
40	0.90	0.82	0.77	0.73	0.66	0.61	0.58	0.55	0.54	0.53	0.53	0.52	0.52
50	1.00	0.90	0.83	0.79	0.70	0.63	0.60	0.57	0.55	0.54	0.53	0.53	0.52
65		1.00	0.93	0.87	0.76	0.67	0.63	0.59	0.57	0.55	0.54	0.53	0.53
80			1.00	0.96	0.82	0.71	0.66	0.61	0.58	0.56	0.55	0.54	0.53
100				1.00	0.90	0.77	0.70	0.63	0.60	0.58	0.57	0.55	0.54
125					1.00	0.83	0.75	0.67	0.63	0.60	0.58	0.56	0.55
150						0.90	0.80	0.70	0.65	0.62	0.60	0.58	0.56
200						1.00	0.90	0.77	0.70	0.66	0.63	0.60	0.58
250							1.00	0.83	0.75	0.70	0.67	0.63	0.60
300								0.90	0.80	0.74	0.70	0.65	0.62
450								1.00	0.95	0.86	0.80	0.73	0.68
600									1.00	0.98	0.90	0.80	0.74
1000										1.00	1.00	1.00	0.90
1250													1.00

WERCS AnkaScrew™

STRENGTH LIMIT STATE DESIGN

Table 4e Multiple anchors effect, concrete edge shear, X_{vn}

Note: For single anchor designs, $X_{vn} = 1.0$

Anchor spacing / Edge distance, a / e	0.20	0.40	0.60	0.80	1.00	1.20	1.40	1.60	1.80	2.00	2.25	2.50
Number of anchors, n												
2	1.00	1.00	1.00	1.00	1.00	1.00	1.00	1.00	1.00	1.00	1.00	1.00
3	0.72	0.76	0.80	0.83	0.86	0.88	0.91	0.93	0.95	0.96	0.98	1.00
4	0.57	0.64	0.69	0.74	0.79	0.82	0.86	0.89	0.92	0.94	0.97	1.00
5	0.49	0.57	0.63	0.69	0.74	0.79	0.83	0.87	0.90	0.93	0.97	1.00
6	0.43	0.52	0.59	0.66	0.71	0.77	0.81	0.85	0.89	0.93	0.96	1.00
7	0.39	0.48	0.56	0.63	0.69	0.75	0.80	0.84	0.88	0.92	0.96	1.00
8	0.36	0.46	0.54	0.61	0.68	0.74	0.79	0.84	0.88	0.92	0.96	1.00
9	0.34	0.44	0.52	0.60	0.67	0.73	0.78	0.83	0.87	0.91	0.96	1.00
10	0.32	0.42	0.51	0.59	0.66	0.72	0.77	0.82	0.87	0.91	0.96	1.00
15	0.26	0.37	0.47	0.55	0.63	0.70	0.76	0.81	0.86	0.90	0.95	1.00
20	0.23	0.35	0.45	0.54	0.61	0.68	0.75	0.80	0.85	0.90	0.95	1.00

Table 4f Anchor at a corner effect, concrete edge shear, X_{vs}

Note: For $e_1/e_2 > 1.25$, $X_{vs} = 1.0$

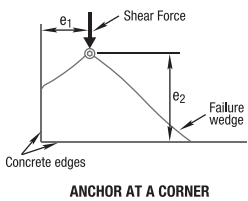

Edge distance, e_2 (mm)	25	30	35	50	60	75	125	200	300	400	600	900
Edge distance, e_1 (mm)												
25	0.86	0.77	0.70	0.58	0.53	0.49	0.41	0.37	0.35	0.34	0.32	0.32
30	0.97	0.86	0.78	0.64	0.58	0.52	0.43	0.38	0.36	0.34	0.33	0.32
35	1.00	0.95	0.86	0.69	0.63	0.56	0.46	0.40	0.37	0.35	0.33	0.32
50	1.00	1.00	1.00	0.86	0.77	0.67	0.52	0.44	0.39	0.37	0.35	0.33
60	1.00	1.00	1.00	0.97	0.86	0.75	0.57	0.47	0.41	0.38	0.36	0.34
75	1.00	1.00	1.00	1.00	1.00	0.86	0.64	0.51	0.44	0.41	0.37	0.35
125	1.00	1.00	1.00	1.00	1.00	1.00	0.86	0.65	0.53	0.48	0.42	0.38
200	1.00	1.00	1.00	1.00	1.00	1.00	1.00	0.86	0.67	0.58	0.49	0.42
300	1.00	1.00	1.00	1.00	1.00	1.00	1.00	1.00	0.86	0.72	0.58	0.49
400	1.00	1.00	1.00	1.00	1.00	1.00	1.00	1.00	1.00	0.86	0.67	0.55
500	1.00	1.00	1.00	1.00	1.00	1.00	1.00	1.00	1.00	1.00	0.77	0.61
600	1.00	1.00	1.00	1.00	1.00	1.00	1.00	1.00	1.00	1.00	0.86	0.67
900	1.00	1.00	1.00	1.00	1.00	1.00	1.00	1.00	1.00	1.00	1.00	0.86

Checkpoint 4

Design reduced ultimate concrete edge shear capacity, ϕV_{urc}

$$\phi V_{urc} = \phi V_{uc} * X_{vc} * X_{vd} * X_{va} * X_{vn} * X_{vs}$$

STEP 5

Verify anchor shear capacity - per anchor

Table 5a Reduced characteristic ultimate steel shear capacity, ϕV_{us} (kN), $\phi_v = 0.8$

Anchor size, d_b (mm)	6	8	10	12	16
$h \geq 5 \times d_h$	6.8	12.6	20.7	25.0	55.4
$h \geq 6 \times d_h$	7.7	14.3	23.4	28.4	62.8
$h \geq 7 \times d_h$	8.6	16.0	26.2	31.7	70.2
$h \geq 7.5 \times d_h$	9.1	16.8	27.5	33.4	73.9

WERCS AnkaScrew™

STRENGTH LIMIT STATE DESIGN

Checkpoint 5

Design reduced ultimate shear capacity, ϕV_{ur}

$\phi V_{ur} = \text{minimum of } \phi V_{urc}, \phi V_{us}$

Check $V^* / \phi V_{ur} \leq 1$,

if not satisfied return to step 1

Shear performance conversion table

Performance Required	Concrete Shear Performance		Steel Shear Performance	
	Notation	Concrete Shear Capacity	Notation	Carbon Steel Shear Capacity
Strength Limit State	ϕV_{uc}	MULTIPLY $\phi V_{uc} \times 1.00$	ϕV_{us}	MULTIPLY $\phi V_{us} \times 1.00$
Working Load Limit	V_{ac}	MULTIPLY $\phi V_{uc} \times 0.55$	V_{as}	MULTIPLY $\phi V_{us} \times 0.50$
Cyclic Loading	V_{yc}	MULTIPLY $\phi V_{uc} \times 0.55$	V_{ys}	MULTIPLY $\phi V_{us} \times 0.50$
Fire Resistance	$V_{Rk,c,fi,t}$	Refer to Fire Rated Anchors	$V_{Rk,s,fi,t}$	Refer to Fire Rated Anchors
Seismic	$V_{Rd,c,sis}^0$	Refer to Seismic Anchors	$V_{Rd,s,sis}^0$	Refer to Seismic Anchors

NOTE: Design Shear Capacity is the minimum of Concrete Shear and Steel Shear Capacities

STEP 6

Combined loading and specification

Checkpoint 6

Check

$N^* / \phi N_{ur} + V^* / \phi V_{ur} \leq 1.2$,

if not satisfied return to step 1

Specify

Ramset WERCS AnkaScrew Anchor,
(Anchor Size) ((Part Number).
Maximum fixed thickness to be (t) mm.

Example

Ramset WERCS AnkaScrew Anchor,
12 mm (AS12100W50).
Maximum fixed thickness to be 40 mm.
To be installed in accordance to Ramset™
Installation Instructions.

DynaBolt™ Plus

SLEEVE ANCHORS - NON-CRACKED CONCRETE

[Back to index](#)

Mechanical Anchoring

GENERAL INFORMATION

Performance Related	Material Specification	Installation Related

Product

The DynaBolt™ Plus Sleeve Anchor is a medium duty, torque setting expansion anchor.

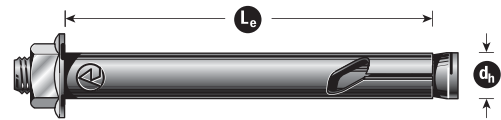

Benefits, Advantages and Features

Improved security:

- Patented sleeve crushes to close gaps up to 5 mm and pulls down to induce clamp load.

Fast installation:

- Through fixing eliminates marking out and repositioning of fixtures.

Versatile:

- Choice of head styles.

Superior corrosion resistance:

- From AISI 316(A4) Stainless Steel.

Outstanding exterior durability:

- 42 micron Hot Dip Galvanised coating.

Ramset Design Method:

* Uses technical data validated from testing in ANZ concrete substrates.

Principal Applications

- Bottom plate and batten fixing
- Installing signs, handrails and gates
- Installing duct work, pipe brackets and suspended ceilings
- Corner guards

Installation

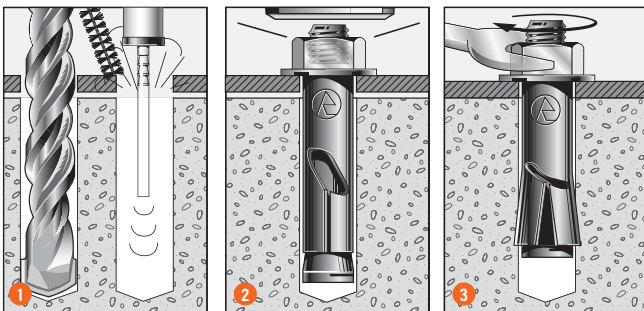

- Use fixture as a template, drill a hole to the correct diameter and depth. Clean hole thoroughly with brush.
- Remove debris by way of a vacuum or hand pump, compressed air, etc. Insert anchor tightly against fixture and tighten with spanner.
- Continue tightening, allowing the sleeve to twist and pull down the fixture firmly onto the base material.

DynaBolt™ Plus

SLEEVE ANCHORS - NON-CRACKED CONCRETE

Mechanical Anchoring

Installation and performance details

Anchor size, d _s (mm)	Installation details				Optimum dimensions*		Reduced Characteristic Capacity - Non-Cracked Concrete			
	Drilled hole diameter, d _h (mm)	Fixture hole diameter, d _f (mm)	Anchor effective depth, h (mm)	Tightening torque, T _r (Nm)	Edge distance, e _c (mm)	Anchor spacing, a _c (mm)	Shear (steel)	Tension (Pull-Through), φN _{up} (kN)**		
							φV _{us} (kN)***	Concrete compressive strength, f _c		
							20 MPa	32 MPa	40 MPa	
6	6	8	20	10	55	60	5.0	2.9	3.7	4.1
			25		55	75	5.0	2.9	3.7	4.1
8	8	10	30	15	60	90	8.0	4.1	5.2	5.8
			35		60	105	8.0	4.1	5.2	5.8
10	10	12	35	35	70	105	12.7	5.2	6.6	7.4
			45		70	135	12.7	5.2	6.6	7.4
12	12	15	40	55	70	120	15.8	7.2	9.1	10.2
			50		75	150	15.8	7.2	9.1	10.2
16	16	19	55	85	85	165	20.9	11.3	14.3	16.0
			65		100	195	20.9	11.3	14.3	16.0
20	20	24	70	165	105	210	31.1	15.3	19.4	21.7
			85		130	255	31.1	15.3	19.4	21.7

* Note: For shear loads acting towards an edge or where these optimum dimensions are not achievable, please use the simplified strength limit state design process to verify capacity.

**Note: Reduced characteristic ultimate Pull-Through tensile capacity = φN_{up} where φ = 0.65 and N_{up} = Characteristic ultimate Pull-Through tensile capacity.

For conversion to Working Load Limit MULTIPLY φN_{up} x 0.51

***Note: Values for shear limited by steel - Reduced characteristic ultimate steel shear capacity = φV_{us} where φ = 0.80 and V_{us} = Characteristic ultimate steel shear capacity.

All data relevant for Non-cracked concrete

DESCRIPTION AND PART NUMBERS

Anchor size, d _h (mm)	Effective length, L _e (mm)	Part No.		
		Zn	Gal	S/S
6	23	DP6026	-	-
	34	DP06040	-	DP06040SS
	53	DP06060	-	DP06060SS
8	34	DP08040	-	DP08040SS
	60	DP08065	-	DP08065SS
	86	DP08090	-	-
10	34	DP10040	DP10040GH	-
	42	DP10050	DP10050GH	DP10050SS
	69	DP10075	DP10075GH	DP10075SS
	96	DP10100	DP10100GH	DP10100SS
	117	DP10125	-	-

Anchor size, d _h (mm)	Effective length, L _e (mm)	Part No.		
		Zn	Gal	S/S
12	47	DP12060	DP12060GH	DP12060SS
	62	DP12070	DP12070GH	DP12070SS
	90	DP12100	DP12100GH	DP12100SS
	118	DP12125	DP12125GH	DP12125SS
16	51	DP16065	DP16065GH	-
	95	DP16110	DP16110GH	-
	129	DP16140	DP16140GH	-
20	70	DP20080	DP20080GH	-
	102	DP20115	DP20115GH	-
	146	DP20160	-	-

Effective depth, h (mm)

h = lesser of L_e - t, 5 * d_h

t = total thickness of material(s) being fixed

Substrate thickness, b_m (mm)

b_m = 2 x h

Drilled hole depth, h₁ (mm)

h₁ = h + d_h

h = Effective depth

ENGINEERING PROPERTIES

Anchor size, d _h (mm)	Thread size, d _b	Stress area, A _s (mm ²)	Carbon steel		Stainless steel		Section modulus Z (mm ³)
			Yield strength, f _y (MPa)	UTS, f _u (MPa)	Yield strength, f _y (MPa)	UTS, f _u (MPa)	
6	M4.5	11.3	720	900	480	600	5.4
8	M6	20.1	640	800	480	600	12.7
10	M8	36.6	560	700	480	600	31.2
12	M10	58.0	440	550	480	600	62.3
16	M12	84.3	400	500	-	-	109.2
20	M16	157.0	320	400	-	-	277.5

DynaSet™

DROP IN ANCHORS - NON-CRACKED CONCRETE

[Back to index](#)

GENERAL INFORMATION

Performance Related	Material Specification	Installation Related

Product

The DynaSet™ Drop-In Anchor is a medium duty, displacement setting expansion anchor.

Benefits, Advantages and Features

Fast installation:

- Shallow embedment and simple setting action.

Convenient:

- Threaded rod can be cut to equal lengths.
- Flanged version sits flush with surface in overdrilled holes.

Ideal as reusable anchorage point:

- Internal threaded design.
- No protruding metal parts when bolt or rod is removed.

Superior corrosion resistance:

- AISI 316(A4) Stainless Steel.

Ramset Design Method:

* Uses technical data validated from testing in ANZ concrete substrates

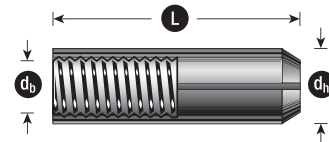

Principal Applications

- Suspended services, such as cable tray, ventilation ducts or plumbing fixtures
- Stadium seating
- Holding down machinery
- Installing racking
- Suspended ceilings

Installation



1. Drill hole at recommended diameter, to at least the anchor length in depth. Clean hole thoroughly with a brush. Remove debris by way of a vacuum pump, compressed air, hand pump etc.
2. Insert anchor and push to required depth. Using the special setting tool, drive the expander plug down until shoulder of the setting punch meets top of the anchor.
3. Position fixture then insert the bolt and tighten with spanner. The DynaSet™ Drop-In anchor remains set in position if the bolt is removed.

DynaSet™

DROP IN ANCHORS - NON-CRACKED CONCRETE

Mechanical Anchoring

Installation and performance details

Anchor size, d _b	Installation details			Optimum dimensions*		Reduced Characteristic Capacity - Non-Cracked Concrete			
	Drilled hole diameter, d _h (mm)	Anchor effective depth, h (mm)	Tightening torque, T _r (Nm)	Edge distance, e _c (mm)	Anchor spacing, a _c (mm)	Shear (steel)	Tension (concrete), φN _{uc} (kN)**		
						φV _{us} (kN)***	Concrete compressive strength, f' _c		
					20 MPa		32 MPa	40 MPa	
M6	8	23	6	80	60	4.5	3.6	4.6	5.1
M6 Flanged	8	23	6	80	60	5.8	3.6	4.6	5.1
M8	10	28	10	100	70	5.8	4.9	6.1	6.9
M10	12	38	20	135	95	7.1	7.7	9.7	10.8
M10 Flanged	12	28	12	100	70	5.8	4.9	6.1	6.9
M12	16 #	48	40	170	120	13.2	10.9	13.8	15.4
M12 Flanged	16	48	40	170	120	13.2	10.9	13.8	15.4
M16	20	63	95	220	160	20.9	16.4	20.7	23.2
M20	25	78	180	275	195	26.3	22.6	28.5	31.9

* Note: For shear loads acting towards an edge or where these optimum dimensions are not achievable, please use the simplified strength limit state design process to verify capacity.

**Note: Reduced characteristic ultimate concrete tensile capacity = φN_{uc} where φ = 0.60 and N_{uc} = Characteristic ultimate concrete tensile capacity.

For conversion to Working Load Limit MULTIPLY φN_{uc} x 0.55

*** Note: Values for shear limited by steel - Reduced characteristic ultimate steel shear capacity = φV_{us} where φ = 0.80 and V_{us} = Characteristic ultimate steel shear capacity.

Note: Hole diameter = 15mm for M12SS

All data relevant for Non-cracked concrete

DESCRIPTION AND PART NUMBERS

Anchor size, d _b	Anchor length, L (mm)	Effective depth, h (mm)	Thread length, L _t (mm)	Part No.	
				Zn	S/S
M6	25	23	11	DSM06	DSM06SS
M6 Flanged	25	23	11	DSF06	-
M8	30	28	13	DSM08	DSM08SS
M10	40	38	16	DSM10	DSM10SS
M10 Flanged	30	28	14	DSF10	-
M12	50	48	21	DSM12	DSM12SS
M12 Flanged	50	48	21	DSF12	-
M16	65	63	28	DSM16	-
M16	60	58	28	-	DSM16SS
M20	80	78	35	DSM20	-

Substrate thickness, b_m (mm)
b_m = 2 x h

Drilled hole depth, h₁ (mm)
h₁ = L + 3
L = Anchor Length

ENGINEERING PROPERTIES

Anchor size, d _b	Anchor stress area, A _s (mm ²)	Carbon Steel		Stainless Steel		Section modulus, Z (mm ³)
		Yield strength, f _y (MPa)	UTS, f _u (MPa)	Yield strength, f _y (MPa)	UTS, f _u (MPa)	
M6	24.3	350	440	480	600	36.9
M8	32.0	350	440	480	600	63.7
M10	40.7	340	430	480	600	100.2
M12	96.3	260	320	-	-	292.9
M12 S/S	72.0	-	-	480	600	214.9
M16	125.5	320	450	480	600	502.1
M20	198.3	198.3	450	480	600	789.6

Introduction

BRICK AND BLOCK ANCHORING

[Back to index](#)

Brick & Block Anchoring

Ramset™ provides a range of concrete anchors for anchoring into pre-manufactured masonry units from lightweight fixtures to heavy structural connections including stud types and hex bolt finishes.

Anchoring into pre-manufactured masonry units such as concrete blocks, wire cut extruded clay brick and pressed solid bricks requires a different approach to anchoring into solid in-situ concrete or precast concrete units. The anchor must firmly clamp a fixture to the face of the substrate without splitting it or causing other damage. The capacity of the anchors is frequently limited by the strength of the substrate, and the strength of the various units available on the market varies from manufacturer to manufacturer and from region to region within any one manufacturer. Also being discrete units rather than a continuous slab means the anchor will always be in close proximity to an edge of that individual unit whilst also possibly being centrally placed within the overall structure.

Ideally all anchors into these pre-manufactured masonry units should be in the centre of the block or brick and in the case of hollow units such as wire cut bricks and concrete blocks the anchors should be placed in the solid section of the unit, but it is not always practical to position fixtures to ensure this.

This section provides performance information to aid design of connections to pre-manufactured masonry units. It assists design by recognising that positioning anchorage points in the centre of a masonry unit is not always possible by providing capacities for zones rather than specific points and we have also endeavoured to provide a realistic evaluation of the anchor's performance in the poorest performing section within these zones.

Please note that as the performance information on

pre-manufactured masonry substrates is provided by the various manufacturers in Working Load Limit format our anchor performance data in this section is also provided in Working Load Limit format.

For lightweight applications into Brick and Block a number of alternate Ramset™ Concrete Anchors may be considered.

1. ShureDrive™ (refer to Tech Data Sheet).
2. EasyDrive™ Nylon Anchors (refer to Tech Data Sheet).

The performance of the above anchors is not dependent on the substrate and therefore you may refer to the performance figures detailed in the Tech Data Sheets available from the Ramset Website.

Anchoring into core filled hollow blocks

In hollow block masonry, where the cores are filled with concrete grout, Ramset™ anchors may be designed and specified similarly as in concrete, provided the designer assesses the effective strength of the masonry including the joints.

However it is not advisable to use certain heavy duty anchors, such as Spatec™ Xtrem™, Boa™ Coil, DynaSet™, and Maxima™ Capsule anchors. Note that DynaBolt™ Plus, TruBolt™ Xtrem™ and WERCS AnkaScrew™ anchors should be limited to 12mm anchor size and ChemSet™ Injection anchors should be no greater than M16.

Typical Masonry UNITS

[Back to index](#)

Brick & Block Anchoring

TYPICAL MASONRY UNITS

TYPICAL DIMENSIONS

CLAY BRICK - Overall

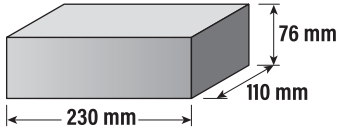

SOLID BRICK

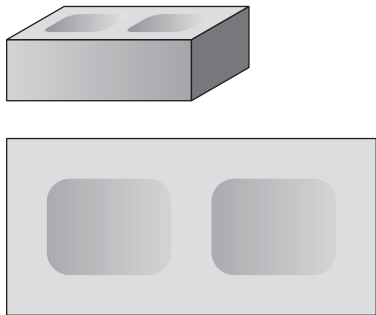

THREE HOLE BRICK

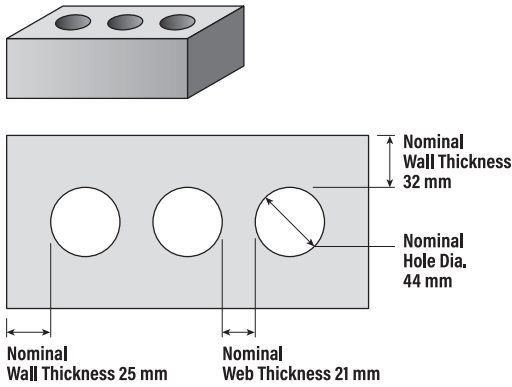

TEN HOLE BRICK

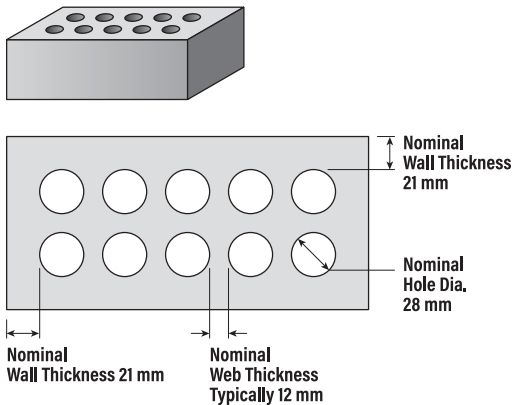

CONCRETE BLOCK - Overall

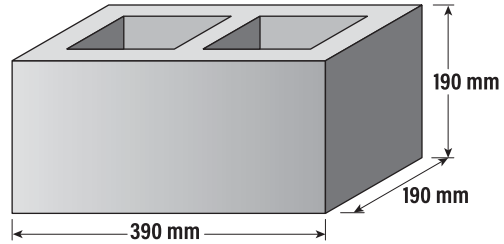

CONCRETE BLOCK

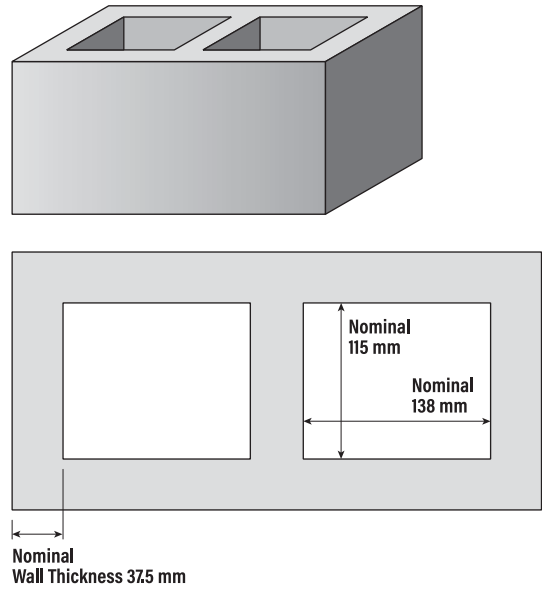

Note: Due to the manufacturing process, the internal cavities have tapered walls. Wall thickness indicated is a nominal dimension only, taken from the centre of the block.

CHARACTERISTIC UNCONFINED COMPRESSIVE STRENGTH

Solid Clay Brick	Three Hole Clay Brick	Ten Hole Clay Brick	Concrete Block
> 10 MPa	> 30 MPa	> 15 MPa	> 8 MPa

Typical Masonry UNITS

Brick & Block Anchoring

INSTALLATION RECOMMENDATIONS

Corner - Brick

- One anchor per brick.
- Minimum edge distance = one brick.

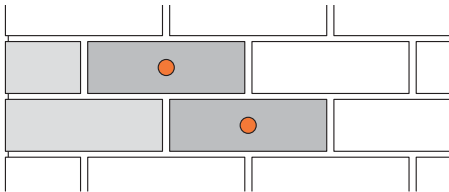

Corner - Block

- One anchor per cavity.
- Minimum edge distance = 1/2 block.

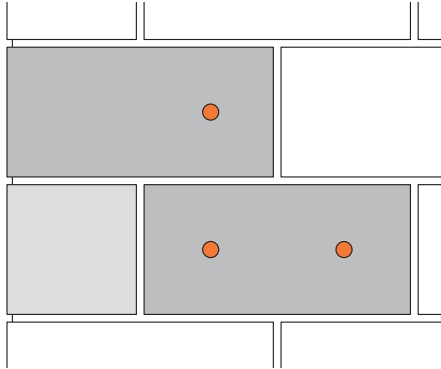

Top of Wall - Brick

- One anchor per brick.
- Three clear courses down from top of wall.

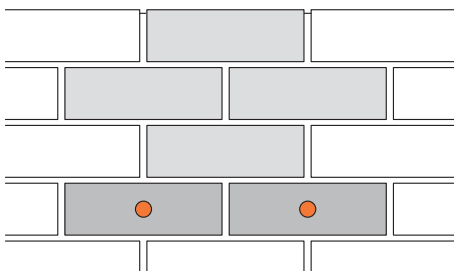

Top of Wall - Block

- One anchor per cavity.
- Two clear courses down from top of wall.

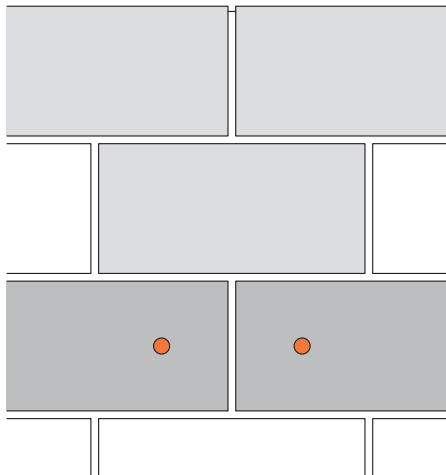

MINIMUM EDGE DISTANCES

CLAY BRICK

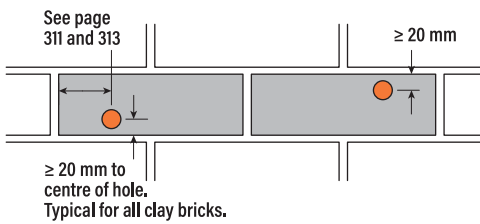

CONCRETE BLOCK

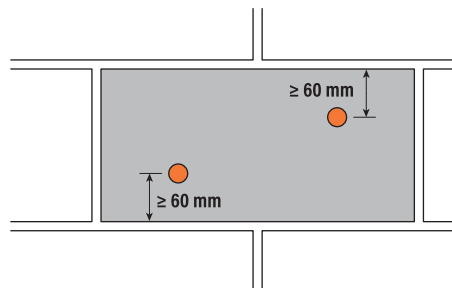

Typical Masonry UNITS

FIXINGS PER BRICK/BLOCK

SOLID BRICK

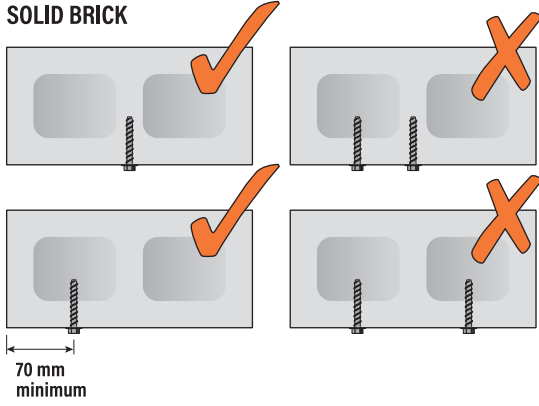

THREE HOLE BRICK

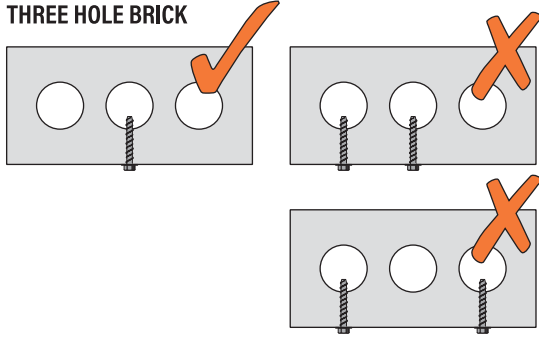

TEN HOLE BRICK

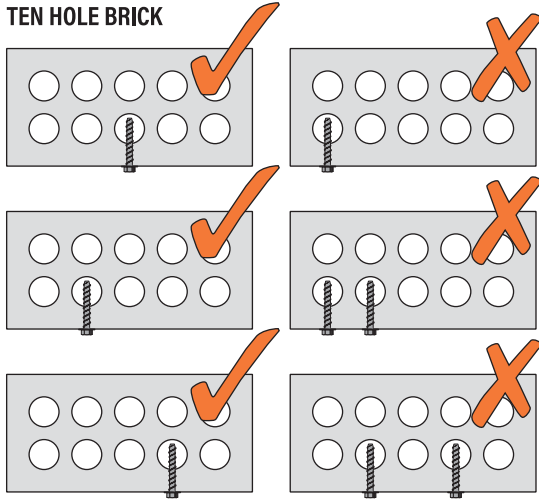

CONCRETE BLOCK

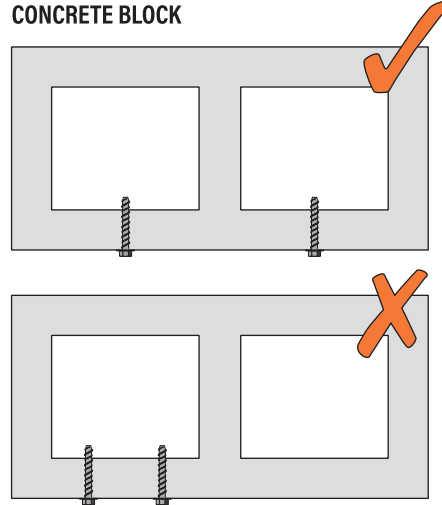

ChemSet™ 101 PLUS

CHEMICAL INJECTION ANCHORING

[Back to index](#)

Brick & Block Anchoring

GENERAL INFORMATION

Performance Related	Material Specification	Installation Related

Product

ChemSet Injection 101 PLUS is a medium duty, peroxide initiated injection anchor.

Benefits, Advantages and Features

Fast installation:

- Load in 50 min. (at 20°C).

Versatile:

- Suitable for anchoring into pre-manufactured masonry units.

Australian Made



Principal Applications into Brick and Block

- Installing wall mounted signs, handrails, and gates

Installation

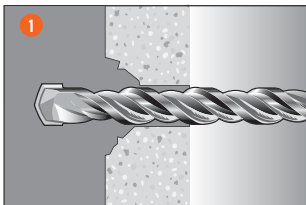

1. Drill recommended diameter and depth hole.

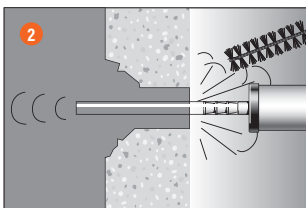

2. **Important:** Clean dust and debris from hole with stiff wire or nylon brush and blower in the following sequence: blow x 4, brush x 3, blow x 4, brush x 3, blow x 4.

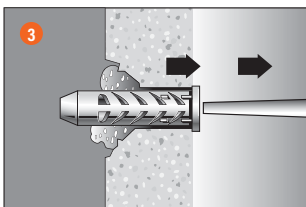

3. Insert mixing nozzle into sleeve or sieve. Dispense adhesive to waste until colour is uniform light grey (2-3 trigger pulls) Fill to 3/4 the sleeve/sieve depth slowly, ensuring no air pockets form. Insert **Ramset** ChemSet Anchor Stud to bottom of hole while turning.

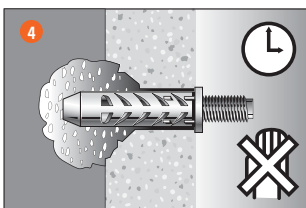

4. ChemSet Injection 101 Plus to cure as per setting times. Attach fixture.

Recommended Installation Temperatures

	Minimum	Maximum
Substrate	5°C	40°C
Adhesive	5°C	40°C

Service Temperature Limits

-40°C to 80°C

Setting Times

Temperature of base material	Cartridge Temperature	Gel Time	Curing time in dry and wet concrete
5°C	5°C	18 min	145 min
10°C	10°C	10 min	85 min
20°C	20°C	6 min	50 min
25°C	25°C	5 min	40 min
+30°C	+30°C	5 min	35 min

Note: Cartridge temperature minimum +5°C

ChemSet™ 101 PLUS

CHEMICAL INJECTION ANCHORING

Back to index

Brick & Block Anchoring

Installation and Working Load Limit performance details: ChemSet™ Injection 101 PLUS and ChemSet™ Anchor Studs

Anchor size, d _b (mm)	Substrate	Sleeve/Sieve Type	Installation details				Working Load Limit (kN)	
			Drilled hole diameter, d _h (mm)	Fixture hole diameter, d _f (mm)	Anchor effective depth, h (mm)	Tightening torque, T _r (Nm)	Solid Brick	
							Shear, V _a	Tension, N _a
M8	Solid Clay Brick	-	10	10	80	10	4.4	1.4
M10			12	12	85	20	4.8	1.5
M12			14	15	85	40	5.2	1.6
M16			18	19	85	95	5.2	1.7

Note: Use specified hole size for solid brick. Use of larger hole and/or sleeve/sieve will result in lower capacities.

Anchor size, d _b (mm)	Substrate	Installation details					Working Load Limit (kN)					
		Drilled hole diameter, d _h (mm)		Fixture hole diameter, d _f (mm)	Anchor effective depth, h (mm)	Tightening torque, T _r (Nm)	3 Hole Brick		10 Hole Brick		Concrete Block	
		Nylon Sleeve	S/S Sieve				Shear, V _a	Tension, N _a	Shear, V _a	Tension, N _a	Shear, V _a	Tension, N _a
M8	3 Hole Brick, 10 Hole Brick or Concrete Block	12	12	10	64	10	3.8	2.5	3.0	1.0	1.8	1.8
M10		14	16	12		20	4.6	2.5	4.6	1.0	2.0	1.8
M12		16	16	15		40	5.0	2.5	5.0	1.0	2.0	1.8
M16		-	22	19		95	5.0	2.5	5.0	1.0	2.0	1.8

For lower strength studs, refer to table for reduced steel capacity on page 322.

DESCRIPTION AND PART NUMBERS

Description	Cartridge Size	Part No.
ChemSet™ 101 PLUS Cartridge	380 ml	C101C
ChemSet™ 101 PLUS Jumbo Cartridge	750 ml	C101J
ChemSet™ 101 PLUS Kit	2 x 380 ml	ISKP
Mixer Nozzle for 101 PLUS	-	ISNP

Effective depth, h (mm)

Preferred $h = h_n$ otherwise,

$h = L_e - t$

t = total thickness of material(s) being fastened.

To suit ChemSet™ Anchor Stud	Nylon Sleeve	Stainless Steel Sieve
M8	ISS08	-
M10	ISS10	-
M12	ISS12	ISM12
M16	-	ISM16

ENGINEERING PROPERTIES

Refer to "Engineering Properties" for ChemSet™ Anchor Studs.

WERCS AnkaScrew™

SCREW IN ANCHORS

[Back to index](#)

Brick & Block Anchoring

GENERAL INFORMATION

Performance Related	Material	Installation Related

Product

The WERCS AnkaScrew Anchor is a medium duty, rotation setting thread forming anchor.

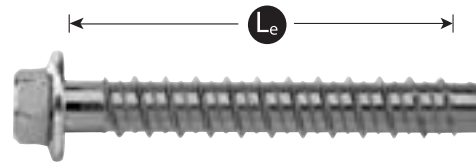

Benefits, Advantages and Features

Fast and easy to install:

- Simply screws into hole.

Fast and easy to remove:

- Screws out leaving an empty hole with no protruding metal parts to grind off.

Close to edge and for close anchor spacing:

- Does not expand and burst brick and block.

Principal Applications into Brick and Block

- Wall mounted pipe brackets.
- Gate hinges.

Installation

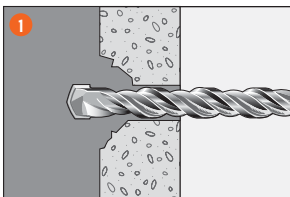

1. Drill hole to correct diameter and depth.

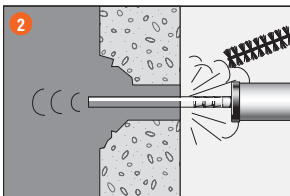

2. Clean thoroughly with brush. Remove debris by way of vacuum or hand pump, compressed air etc.

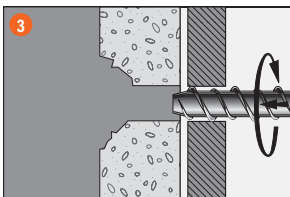

3. Using a socket wrench, screw the AnkaScrew into the hole using slight pressure until the self tapping action starts.

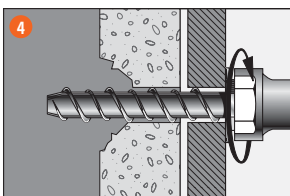

4. Tighten the AnkaScrew. If resistance is experienced when tightening, unscrew anchor one turn and re-tighten. Ensure not to over tighten.

WERCS AnkaScrew™

SCREW IN ANCHORS

Installation and Working Load Limit performance details

Anchor size, d_b (mm)	Installation details				Working Load Limit (kN)							
	Drilled hole diameter, d_h (mm)	Fixture hole diameter, d_f (mm)	Anchor effective depth, h (mm)	Tightening torque, T_t (Nm)	Solid Brick		3 Hole Brick		10 Hole Brick		Concrete Block	
					Shear, V_a	Tension, N_a	Shear, V_a	Tension, N_a	Shear, V_a	Tension, N_a	Shear, V_a	Tension, N_a
5	5	7	25	8	1.5	1.2	1.2	1.0	1.1	0.5	1.2	0.8
6	6	8	30	10	3.2	1.8	3.0	2.4	1.8	0.60	2.1	0.90
8	8	10	40	10	4.0	2.7	3.8	2.7	2.3	0.65	2.1	1.00
10	10	12	50	15	4.4	3.9	4.2	2.8	2.5	0.65	2.1	1.00
12	12	15	60	15	4.4	4.5	4.2	3.0	2.5	0.70	2.1	1.15

DESCRIPTION AND PART NUMBERS

Anchor size, d_b	Effective length, L_e (mm)	Part No.	
		Zn Hex Head	Gal Hex Head
5	24	AS05030	-
6	44	AS06050W100	AS06050WGM100
	69	AS06075W100	AS06075WGM100
	94	AS060100W100	AS060100WGM100
8	54	AS08060W100	AS08060WGM100
	69	AS08075W100	AS08075WGM100
	94	AS080100W100	AS080100WGM100
10	54	AS10060W50	AS10060WGM50
	69	AS10075W50	AS10075WGM50
	94	AS10100W50	AS10100WGM50
12	69	AS12075W50	AS12075WGM50
	94	AS12100W50	AS12100WGM50
	144	AS12150W20	AS12150WGM20

Effective depth, h (mm)

$$h = L_e - t$$

t = total thickness of material(s) being fixed

ENGINEERING PROPERTIES

Anchor size, d_h (mm)	Stress area, A_s (mm ²)	Yield strength, f_y (MPa)	UTS, f_u (MPa)
6	15.9	640	800
8	42.4	640	800
10	69.4	640	800
12	84.1	640	800

DynaBolt™ Plus

HEX BOLT

[Back to index](#)

Brick & Block Anchoring

GENERAL INFORMATION

Performance Related	Material	Installation Related

Product

The DynaBolt™ Plus Anchor Hex Bolt is a medium duty, torque setting expansion anchor.

Features and Benefits

Ideal for hollow substrates:

- Cone nut pulls up in cavity to clamp fixture to substrate.

Neat finish:

- Low profile hex head.

High shear strength:

- High tensile Grade 8.8 Steel Bolt.

Fast installation:

- Through fixing eliminates marking out and repositioning of fixture.

Convenient to remove:

- No metal parts protrude from hole eliminating grinding.

Economical Zinc Plated or superior corrosion resistant

AISI 316 Stainless Steel.

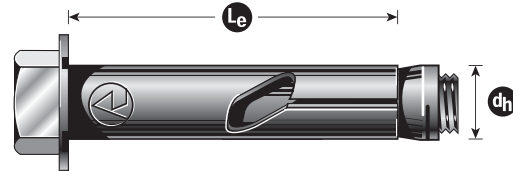

Principal Applications into Brick and Block

- Electrical junction boxes
- Wall mounted pipe brackets
- Installing wall mounted signs, handrails and gates
- Roller door guide rails

Installation

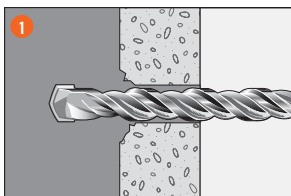

1. Drill hole to correct diameter and depth.

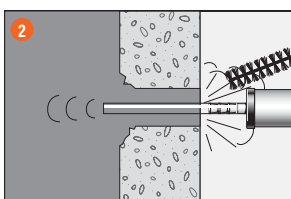

2. Clean thoroughly with brush. Remove debris by way of vacuum or hand pump, compressed air etc.

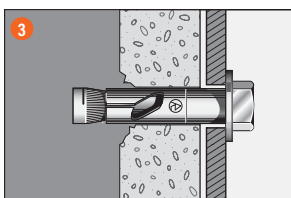

3. Insert DynaBolt™ Plus Anchor Hex Bolt through fixture, tap lightly with hammer until washer contacts fixture.

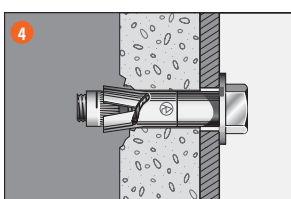

4. Tighten DynaBolt™ Plus Anchor Hex Bolt to specified assembly torque using torque wrench.

DynaBolt™ Plus

HEX BOLT

Installation and Working Load Limit performance details

Anchor size, d_b (mm)	Installation details				Working Load Limit (kN)							
	Drilled hole diameter, d_h (mm)	Fixture hole diameter, d_f (mm)	Anchor effective depth, h (mm)	Tightening torque, T_r (Nm)	Solid Brick		3 Hole Brick		10 Hole Brick		Concrete Block	
					Shear, V_a	Tension, N_a	Shear, V_a	Tension, N_a	Shear, V_a	Tension, N_a	Shear, V_a	Tension, N_a
8	8	10	35	10	3.9	3.1	2.9	3.9	2.0	0.83	1.4	1.0
10	10	12	40	15	4.4	4.6	3.4	4.1	2.3	0.87	1.6	1.0
12	12	15	40	15	4.4	4.6	3.8	4.1	3.1	0.94	2.1	1.0

DESCRIPTION AND PART NUMBERS

Anchor size, d_h (mm)	Effective length, L_e (mm)	Part No.	
		Zn	S/S
8	34	DP08045H	DP08045HSS
	60	DP08070H	DP08070HSS
	86	-	-
10	34	DP10045H	DP10045HSS
	42	DP10055H	-
	56	-	DP10060HSS
	69	DP10080H	DP10080HSS
	96	DP10105H	DP10105HSS
12	47	DP12065H	-
	62	DP12075H	DP12075HSS
	90	DP12105H	-

Effective depth, h (mm)

$h = L_e - t$

t = total thickness of material(s) being fixed

ENGINEERING PROPERTIES

Anchor size, d_h (mm)	Thread size, d_b	Stress area, A_s (mm ²)	Carbon steel		Stainless steel		Section modulus Z (mm ³)
			Yield strength, f_y (MPa)	UTS, f_u (MPa)	Yield strength, f_y (MPa)	UTS, f_u (MPa)	
8	M6	20.1	640	800	480	600	12.7
10	M8	36.6	640	800	480	600	31.2
12	M10	58.0	640	800	480	600	62.3

RamPlug™ ANCHORS

Back to index

Brick & Block Anchoring

GENERAL INFORMATION

Performance Related	Material	Installation Related

Product

The RamPlug Anchor is a light duty, rotation setting interference fit anchor.

Benefits, Advantages and Features

Fast and easy to install:

- Anchor simply hammered in and screw inserted with a screwdriver.

Convenient:

- Collar ensures anchor sits flush with fixture surface.

Versatile:

- Anchor accepts many types of screw.

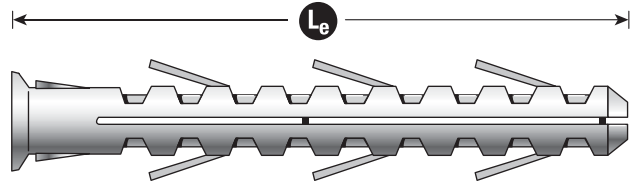

Principal Applications into Brick and Block

- Electrical fittings

Installation

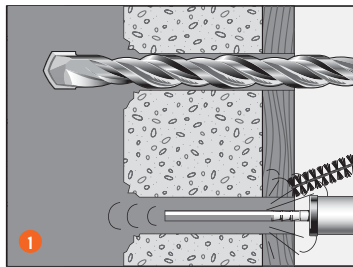

1. Drill hole to correct diameter and depth using the fixture as a template. Clean thoroughly with brush. Remove debris by way of vacuum or hand pump, compressed air etc.

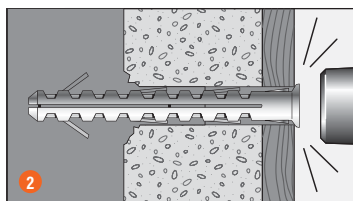

2. For long or ultralong RamPlug insert the RamPlug into hole until flush with the surface of the fixture. For standard RamPlug insert the RamPlug into the hole until flush with the surface of the substrate.

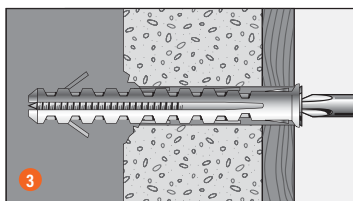

3. Insert screw into the RamPlug. Tighten with screwdriver.
Note:
(1) For standard RamPlug Screw length = length of Ramplug + thickness of fixture
(2) For long RamPlug Screw length = length of Ramplug + thickness of fixture
(3) Ultra long plugs supplied with screw.

RamPlug™

ANCHORS

Installation and Working Load Limit performance details

Anchor	Anchor size, d _b (mm)	Installation details			Working Load Limit (kN)							
		Drilled hole diameter, d _h (mm)	Fixture hole diameter, d _f (mm)	Anchor effective depth, h (mm)	Solid Brick		3 Hole Brick		10 Hole Brick		Concrete Block	
					Shear, V _a	Tension, N _a	Shear, V _a	Tension, N _a	Shear, V _a	Tension, N _a	Shear, V _a	Tension, N _a
DNP05	5	5	6	25	0.40	0.30	0.40	0.20	0.70	0.16	0.40	0.13
DNP06	6	6	7	30	0.80	0.50	0.80	0.25	0.80	0.20	0.80	0.17
DNP07	7	7	7	30	1.10	0.65	1.10	0.32	0.80	0.25	1.10	0.18
DNP08	8	8	8	40	1.30	0.80	1.30	0.35	0.80	0.28	1.30	0.18
DNP10	10	10	9	50	2.40	1.10	1.90	0.45	0.80	0.36	1.90	0.19
DNP12	12	12	12	60	3.00	1.50	2.20	0.55	0.90	0.44	2.20	0.22
DLP08	8	8	8	70	1.30	0.80	Performance to be determined.					
DLP10	10	10	9	70	2.40	1.10						
DUP10080	10	10	9	70	2.40	0.60						
DUP10100	10	10	9	70	2.40	0.60						
DUP10135	10	10	9	70	2.40	0.60						
DUP10160	10	10	9	70	2.40	0.60						

DESCRIPTION AND PART NUMBERS

Anchor size, d _b (mm)	Effective length, L _e (mm)	Part No.			
		Standard	Long	Ultra Long - C/S Pozi*	Ultra Long - Hex Head
5	25	DNP05	-	-	-
6	30	DNP06	-	-	-
7	30	DNP07	-	-	-
8	40	DNP08	-	-	-
	80	-	DLP08	-	-
10	50	DNP10	-	-	-
	80	-	DLP10	DUP10080F	DUP10080H
	100	-	-	DUP10100F	DUP10100H
	135	-	-	DUP10135F	DUP10135H
	160	-	-	DUP10160F	DUP10160H
12	60	DNP12	-	-	-

* No. 3 Pozi Bit.

Typical Bolt

PERFORMANCE INFORMATION

[Back to index](#)

Typical Bolt Performance Information

Tabulated below are nominal reduced ultimate characteristic capacities for bolts manufactured in accordance with **ISO 898-1**.

It is recommended that Stainless Steel bolts be lubricated and that tightening torque be applied in a smooth, continuous manner. Impact wrenches (rattle guns) are not suitable for the tightening of Stainless Steel fasteners.

The expected capacity of bolts should be independently checked by the designer based on the bolt manufacturers published performance information.

STRENGTH LIMIT STATE DESIGN INFORMATION

Tension

Reduced nominal bolt tensile capacity, ϕN_t (kN), $\phi_n = 0.8$

Bolt type	M6	M8	M10	M12	M16	M20	M24
Grade 4.6 Carbon Steel	6.4	11.7	18.6	27.0	50.2	78.4	113.0
Grade 8.8 Carbon Steel	13.3	24.3	38.5	56.0	104.2	162.7	234.4
Stainless Steel A4-70 (AISI 316)	11.3	20.5	32.5	47.2	87.9	137.2	-

Shear

Reduced nominal bolt shear capacity, ϕV_{sf} (kN), $\phi_v = 0.8$

Bolt type	M6	M8	M10	M12	M16	M20	M24
Grade 4.6 Carbon Steel	3.3	6.1	9.8	14.4	27.4	43.0	62.0
Grade 8.8 Carbon Steel	6.6	12.4	20.0	29.3	56.1	88.3	127.2
Stainless Steel A4-70 (AISI 316)	5.6	10.5	16.8	24.7	47.4	74.5	-

WORKING LOAD LIMIT DESIGN INFORMATION

Tension

Allowable tensile load steel (kN), $F_{ss} = 2.2$

Bolt type	M6	M8	M10	M12	M16	M20	M24
Grade 4.6 Carbon Steel	3.6	6.6	10.6	15.3	28.5	44.5	64.2
Grade 8.8 Carbon Steel	7.6	13.8	21.9	31.8	59.2	92.4	133.2
Stainless Steel A4-70 (AISI 316)	6.4	11.6	18.5	26.8	49.9	77.9	-

Shear

Allowable shear load steel (kN), $F_{sv} = 2.5$

Bolt type	M6	M8	M10	M12	M16	M20	M24
Grade 4.6 Carbon Steel	1.7	3.1	4.9	7.2	13.7	21.5	31.0
Grade 8.8 Carbon Steel	3.3	6.2	10.0	14.7	28.1	44.2	63.6
Stainless Steel A4-70 (AISI 316)	2.8	5.3	8.4	12.4	23.7	37.3	-

Introduction

FIRE RATED ANCHORING SYSTEMS

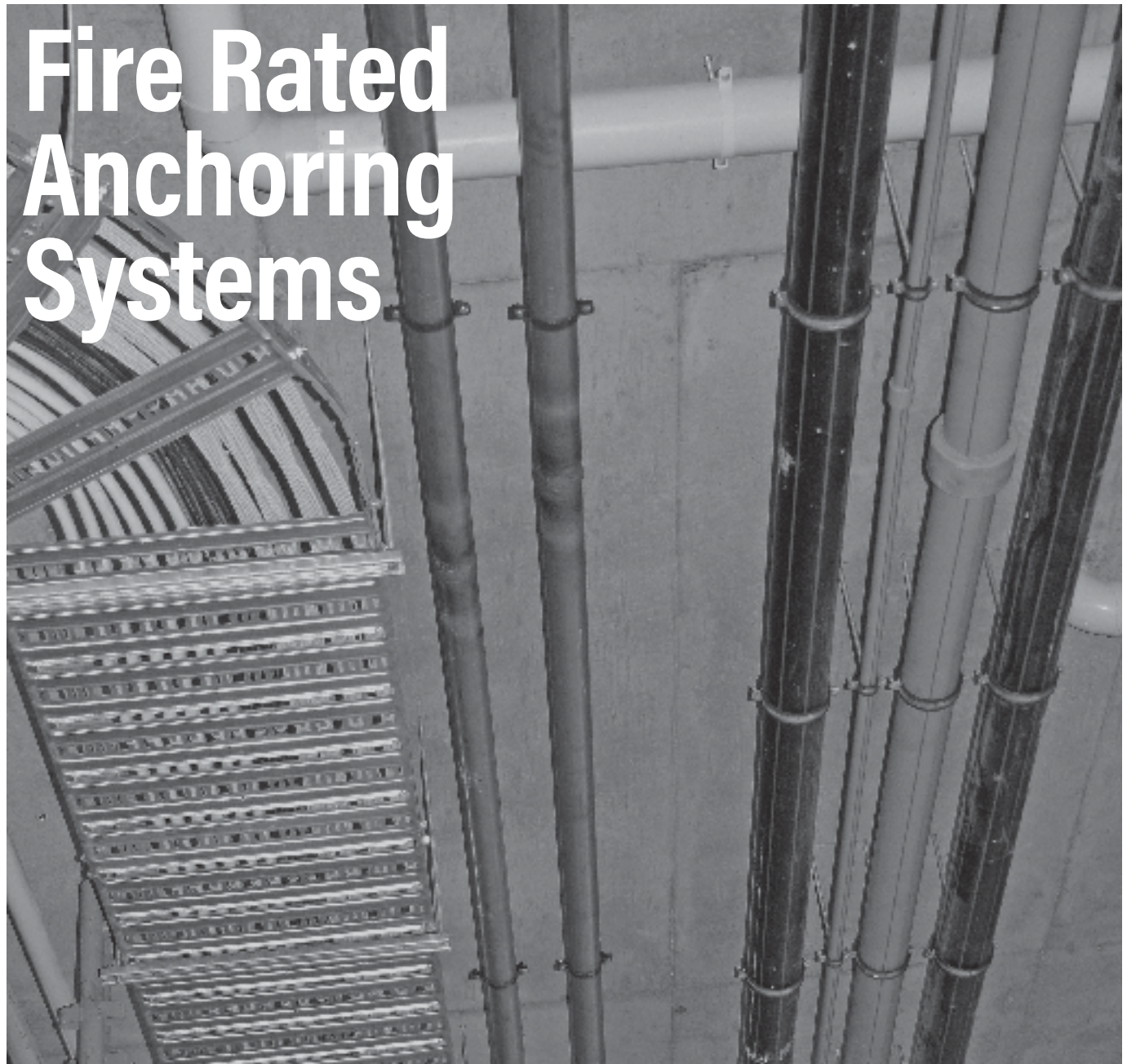
[Back to index](#)

Introduction

Ramset™ has a number of anchoring systems which are specifically designed to achieve Fire Rating requirements for various applications. The existing range of medium duty suspension anchors such as, AnkaScrew™ and DynaSet™ Anchors, have been independently tested in accordance with Australian Fire test standards AS1530.4 to provide up to 2 hours capacity in a fire situation.

Furthermore, Ramset™ also have a range of heavy duty mechanical and chemical anchoring systems such as, SpaTec™ Xtrem™, TruBolt™ Xtrem™, AnkaScrew Xtrem™, EPCON™ C8 Xtrem™, and ChemSet™ 801 Xtrem™, which have all been independently tested for capacity in a fire situation. The Fire resistance duration for these anchoring systems varies with design cases available between 30 to 240 minutes. This section will provide you with data to help with your Fire Rating Level requirements when considering a post-installed fixing system.

Suspension Anchors

FIRE RATED MECHANICAL ANCHOR

[Back to index](#)

Fire Rated Anchoring Systems

GENERAL INFORMATION

Ramset™ Suspension Anchors have been fire rated and designed for fast high strength anchoring of suspension systems.

- AnkaScrew™ 5 x 30mm Hex head for fast fixing of retrofit fire collars, metal boxes and metal ducts.
- DynaSet™ M10 flanged and M12 drop in anchors for heavy duty pipe and cable tray suspensions.

Product

The AnkaScrew™ Anchor is a medium duty, rotation setting thread forming anchor.

Benefits, Advantages and Features

Fast and easy to install:

- Simply screws into hole.

Fast and easy to remove:

- Screws out leaving an empty hole with no protruding metal parts to grind off.

Close to edge and for close anchor spacing:

- Does not expand and burst concrete.

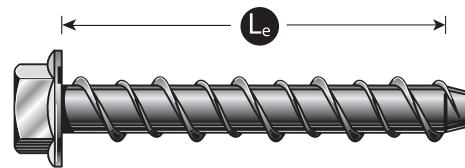

AnkaScrew™ 5 x 30mm Hex head - Part Number AS05030

- Engineered fire protection (2 hour minimum)

Product

The DynaSet™ Anchor is a heavy duty, displacement setting expansion anchor.

Benefits, Advantages and Features

Fast installation:

- Shallow embedment and simple setting action.

Convenient:

- Threaded rod can be cut to equal lengths.
- Flanged version sits flush with surface in overdrilled holes.

Ideal as reusable anchorage point:

- Internal threaded design.
- No protruding metal parts when bolt or rod is removed.

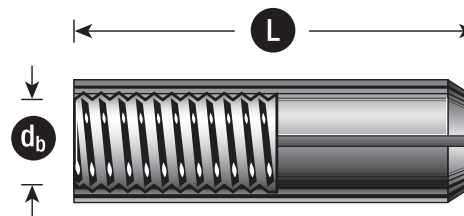

DynaSet™ M10 flanged - Part Number DSF10

M12 drop in anchors - Part Number DSM12

- Fire tested and compliant to AS1530.4-2005
- Engineered fire protection (2 hour minimum)

Principal Applications

- Suspended services, such as cable tray, ventilation ducts or plumbing fixtures
- Installing racking
- Suspended ceilings

IMPORTANT: Consult technical data for tested applications and fire ratings, before commencing use. For detailed technical data and instructions go to www.ramset.com.au. For applications outside those tested, refer to your Fire Consultant for compliance advice.

SpaTec™ Xtrem™

FIRE RATED MECHANICAL ANCHOR

[Back to index](#)

GENERAL INFORMATION

Performance Related	Material	Installation Related

Product

A high security, high performance, through fixing, torque controlled expansion anchor which has approval for use in cracked and non-cracked concrete.



Compliance

European Technical Assessment (option 1) - ETA-10/0276

Design according to:

- AS5216 (formerly TS101)
- AS1170.4 - Earthquake Actions
- EN1992-4 (formerly ETAG001 Annex C, E & TR045)
- NZS3101 (A3) Section 17 - Seismic Design C1 and C2
- Use enclosed data for simplified calculation method

Use Ramset™ iExpert Anchor Software for optimised calculation or where a greater range of anchor layout detail is needed.

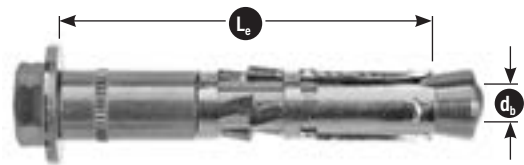

Hex Head

Principal Applications

- Anchoring into cracked & non cracked concrete
- Safety critical loads
- Steel columns & walkways
- Road barrier hold down
- Bridge refurbishment
- Road & Rail tunnel construction
- Wall Plates
- Safety Rails
- Intended working life of the anchor of 50 years

Benefits, Advantages and Features

Fire tested to TR020

- Fire rated performance up to 120 minutes
- Highest level of European approval for mechanical expansion anchors
- Approved for all directions (floor, wall, overhead)
- Shallow embedment depths
- Highest performance in cracked concrete
- Zinc Plated to 5µm

Anchor diameters from M10 to M20

Suitable for structural loads:

- Safety critical loads
- High tensile capacity of Grade 8.8 Steel Bolt.
- Heavy duty, heat treated washer. Heavy duty, thick expansion sleeve that provides secure grip to concrete.

Improved security:

- Large expansion reserve that ensures retention in concrete if overloaded.
- Torque induced pull down closes gaps and induces preload.

Resistant to cyclic loading:

- Heavy duty sleeve with integrated pull-down section works to retain 65% of initial preload.

Fast installation:

- Hex Nut & Hex Bolt versions available
- Countersunk heads available.
- Through fixing eliminates marking out and repositioning of fixtures.

Installation

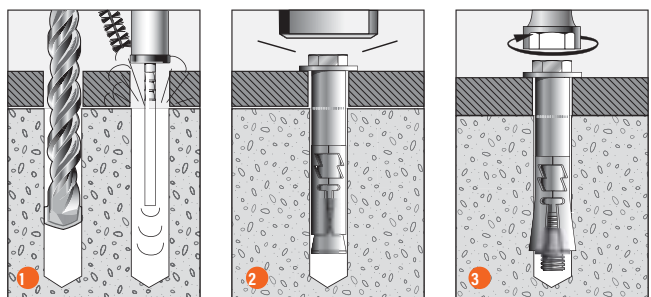

- Drill or core a hole to the recommended diameter and depth using the fixture as a template. Clean the hole thoroughly with a hole cleaning brush. Remove the debris with a hand pump, compressed air, or vacuum.
- After ensuring that the anchor is assembled correctly, insert the anchor through the fixture and drive with a hammer until the washer contacts the fixture.
- Tighten the bolt with a torque wrench to the specified assembly torque.

Fire Rated Anchoring Systems

SpaTec™ Xtrem™

FIRE RATED MECHANICAL ANCHOR

Installation Details

Anchor size, d _b (mm)	Drilled hole diameter, d _h (mm)	Fixture hole diameter, d _f (mm)	Anchor effective depth, h (mm)	Depth of drill hole, h _i (mm)	Tightening torque, T _r (Nm)	Optimum dimensions*		Concrete substrate thickness, b _m (mm)
						Anchor* spacing, a _c (mm)	Edge** distance, e _c (mm)	
M10	15	17	70	90	50	280	140	140
M12	18	20	80	105	80	320	160	160
M16	24	26	100	131	120	400	200	200
M20	28	30	125	157	200	500	250	250

* For optimised performance data, please use Ramset iExpert Anchoring Software.

** If the fire attack is from more than one side, the edge distance of the anchor has to be ≥ 300mm and 2xh.

DESCRIPTION AND PART NUMBERS

Anchor size, d _b (mm)	Drilled hole diameter, d _h (mm)	Effective Length, L _e (mm)	Fixture thickness, t (mm)	ETA Designation Number	Part Number
					Zinc (Hex Hd)
M10	15	90	20	V10-15/20	SP10105
M12	18	90	10	V12-18/10	SP12105
		105	25	V12-18/25	SP12120
M16	24	125	25	V16-24/25	SP16145
M20	28	150	25	V20-28/25	SP20170

ENGINEERING PROPERTIES - Carbon Steel

Anchor size, d _b (mm)	Shank diameter, d _s (mm)	Bolt stress area, A _s (mm ²)	Bolt yield strength, f _y (MPa)	Bolt UTS, f _u (MPa)	Spacer area, A _s (mm ²)	Spacer yield strength, f _y (MPa)	Spacer UTS, f _u (MPa)	Section modulus Z (mm ³)
M10	9.8	58.0	640	800	83.4	350	480	62.3
M12	11.7	84.3	640	800	119.8	330	430	109.2
M16	15.7	157.0	640	800	201.7	330	430	277.5
M20	19.7	245.0	660	800	242.5	330	430	540.9

SpaTec™ Xtrem™

FIRE RATED MECHANICAL ANCHOR

Design Case **1**

Fire resistance duration = 30 minutes

Table 1a Characteristic values of resistance to tension loads in 20 MPa to 50 MPa concrete strength for Fire resistance duration = 30 minutes

Anchor size, d_b		M10	M12	M16	M20
Drilled hole diam, d_h (mm)		15	18	24	28
Effective depth, h (mm)	Characteristic Resistance				
70	Steel Failure - $N_{Rk,s,fi,30}$ (kN)	4.5			
	Pull-out failure concrete - $N_{Rk,p,fi,30}$ (kN)	4.0			
	Concrete cone failure - $N_{Rk,c,fi,30}$ (kN)	7.4			
80	Steel Failure - $N_{Rk,s,fi,30}$ (kN)		17.6		
	Pull-out failure concrete - $N_{Rk,p,fi,30}$ (kN)		-		
	Concrete cone failure - $N_{Rk,c,fi,30}$ (kN)		10.3		
100	Steel Failure - $N_{Rk,s,fi,30}$ (kN)			32.8	
	Pull-out failure concrete - $N_{Rk,p,fi,30}$ (kN)			-	
	Concrete cone failure - $N_{Rk,c,fi,30}$ (kN)			18.0	
125	Steel Failure - $N_{Rk,s,fi,30}$ (kN)				51.1
	Pull-out failure concrete - $N_{Rk,p,fi,30}$ (kN)				-
	Concrete cone failure - $N_{Rk,c,fi,30}$ (kN)				31.4

Note: Bold values indicates limiting load. Data in table lists all possible failure mechanisms due to fire.

Table 1b Characteristic values of resistance to shear loads in 20 MPa concrete strength for Fire resistance duration = 30 minutes

Anchor size, d_b		M10	M12	M16	M20
Drilled hole diam, d_h (mm)		15	18	24	28
Edge distance, e_c (mm)	Characteristic Resistance				
140	Steel Failure without lever arm - $V_{Rk,s,fi,30}^0$ (kN)	4.5			
	Steel Failure with lever arm - $M_{Rk,s,fi,30}^0$ (N.m)	5.8			
	Concrete edge failure - $V_{Rk,c,fi,30}^0$ (kN)	4.9			
160	Steel Failure without lever arm - $V_{Rk,s,fi,30}^0$ (kN)		17.6		
	Steel Failure with lever arm - $M_{Rk,s,fi,30}^0$ (N.m)		27.3		
	Concrete edge failure - $V_{Rk,c,fi,30}^0$ (kN)		6.5		
200	Steel Failure without lever arm - $V_{Rk,s,fi,30}^0$ (kN)			32.8	
	Steel Failure with lever arm - $M_{Rk,s,fi,30}^0$ (N.m)			69.5	
	Concrete edge failure - $V_{Rk,c,fi,30}^0$ (kN)			10.4	
300	Steel Failure without lever arm - $V_{Rk,s,fi,30}^0$ (kN)				51.1
	Steel Failure with lever arm - $M_{Rk,s,fi,30}^0$ (N.m)				135.5
	Concrete edge failure - $V_{Rk,c,fi,30}^0$ (kN)				15.9

Note: Bold values indicates limiting load. Data in table lists all possible failure mechanisms due to fire.

Note: Concrete edge failure values are based on 20 MPa concrete strength. For values in higher concrete strengths, please multiply $V_{Rk,c,fi,30}^0$ by the concrete compressive strength effect X_{vc} , as follows;

f'_c (MPa)	20	30	40	50
X_{vc}	1	1.22	1.41	1.55

SpaTec™ Xtrem™

FIRE RATED MECHANICAL ANCHOR

Design Case **2**

Fire resistance duration = 60 minutes

Table 2a Characteristic values of resistance to tension loads in 20 MPa to 50 MPa concrete strength for Fire resistance duration = 60 minutes

Anchor size, d _b		M10	M12	M16	M20
Drilled hole diam, d _h (mm)		15	18	24	28
Effective depth, h (mm)	Characteristic Resistance				
70	Steel Failure - N _{Rk,s,fi,60} (kN)	3.3			
	Pull-out failure concrete - N _{Rk,p,fi,60} (kN)	4.0			
	Concrete cone failure - N _{Rk,c,fi,60} (kN)	7.4			
80	Steel Failure - N _{Rk,s,fi,60} (kN)		11.4		
	Pull-out failure - N _{Rk,p,fi,60} (kN)		-		
	Concrete cone failure - N _{Rk,c,fi,60} (kN)		10.3		
100	Steel Failure - N _{Rk,s,fi,60} (kN)			21.3	
	Pull-out failure concrete - N _{Rk,p,fi,60} (kN)			-	
	Concrete cone failure - N _{Rk,c,fi,60} (kN)			18.0	
125	Steel Failure - N _{Rk,s,fi,60} (kN)				33.2
	Pull-out failure - N _{Rk,p,fi,60} (kN)				-
	Concrete cone failure - N _{Rk,c,fi,60} (kN)				31.4

Note: Bold values indicates limiting load. Data in table lists all possible failure mechanisms due to fire.

Table 2b Characteristic values of resistance to shear loads in 20 MPa concrete strength for Fire resistance duration = 60 minutes

Anchor size, d _b		M10	M12	M16	M20
Drilled hole diam, d _h (mm)		15	18	24	28
Edge distance, e _c (mm)	Characteristic Resistance				
140	Steel Failure without lever arm - V ⁰ _{Rk,s,fi,60} (kN)	3.3			
	Steel Failure with lever arm - M ⁰ _{Rk,s,fi,60} (N.m)	4.2			
	Concrete edge failure - V ⁰ _{Rk,c,fi,60} (kN)	4.9			
160	Steel Failure without lever arm - V ⁰ _{Rk,s,fi,60} (kN)		11.4		
	Steel Failure with lever arm - M ⁰ _{Rk,s,fi,60} (N.m)		17.8		
	Concrete edge failure - V ⁰ _{Rk,c,fi,60} (kN)		6.5		
200	Steel Failure without lever arm - V ⁰ _{Rk,s,fi,60} (kN)			21.3	
	Steel Failure with lever arm - M ⁰ _{Rk,s,fi,60} (N.m)			45.2	
	Concrete edge failure - V ⁰ _{Rk,c,fi,60} (kN)			10.4	
300	Steel Failure without lever arm - V ⁰ _{Rk,s,fi,60} (kN)				33.2
	Steel Failure with lever arm - M ⁰ _{Rk,s,fi,60} (N.m)				88.1
	Concrete edge failure - V ⁰ _{Rk,c,fi,60} (kN)				15.9

Note: Bold values indicates limiting load. Data in table lists all possible failure mechanisms due to fire.

Note: Concrete edge failure values are based on 20 MPa concrete strength. For values in higher concrete strengths, please multiply V⁰_{Rk,c,fi,60} by the concrete compressive strength effect X_{vc} as follows;

f _c (MPa)	20	30	40	50
X _{vc}	1	1.22	1.41	1.55

SpaTec™ Xtrem™

FIRE RATED MECHANICAL ANCHOR

Design Case **3**

Fire resistance duration = 90 minutes

Table 2a Characteristic values of resistance to tension loads in 20 MPa to 50 MPa concrete strength for Fire resistance duration = 90 minutes

Anchor size, d_h		M10	M12	M16	M20
Drilled hole diam, d_h (mm)		15	18	24	28
Effective depth, h (mm)	Characteristic Resistance				
70	Steel Failure - $N_{Rk,s,fi,90}$ (kN)	2.1			
	Pull-out failure concrete - $N_{Rk,p,fi,90}$ (kN)	4.0			
	Concrete cone failure - $N_{Rk,c,fi,90}$ (kN)	7.4			
80	Steel Failure - $N_{Rk,s,fi,90}$ (kN)		5.3		
	Pull-out failure - $N_{Rk,p,fi,90}$ (kN)		-		
	Concrete cone failure - $N_{Rk,c,fi,90}$ (kN)		10.3		
100	Steel Failure - $N_{Rk,s,fi,90}$ (kN)			9.8	
	Pull-out failure concrete - $N_{Rk,p,fi,90}$ (kN)			-	
	Concrete cone failure - $N_{Rk,c,fi,90}$ (kN)			18.0	
125	Steel Failure - $N_{Rk,s,fi,90}$ (kN)				15.3
	Pull-out failure - $N_{Rk,p,fi,90}$ (kN)				-
	Concrete cone failure - $N_{Rk,c,fi,90}$ (kN)				31.4

Note: Bold values indicates limiting load. Data in table lists all possible failure mechanisms due to fire.

Table 2b Characteristic values of resistance to shear loads in 20 MPa concrete strength for Fire resistance duration = 90 minutes

Anchor size, d_h		M10	M12	M16	M20
Drilled hole diam, d_h (mm)		15	18	24	28
Edge distance, e_c (mm)	Characteristic Resistance				
140	Steel Failure without lever arm - $V_{Rk,s,fi,90}^0$ (kN)	2.1			
	Steel Failure with lever arm - $M_{Rk,s,fi,90}^0$ (N.m)	2.7			
	Concrete edge failure - $V_{Rk,c,fi,90}^0$ (kN)	4.9			
160	Steel Failure without lever arm - $V_{Rk,s,fi,90}^0$ (kN)		5.3		
	Steel Failure with lever arm - $M_{Rk,s,fi,90}^0$ (N.m)		8.2		
	Concrete edge failure - $V_{Rk,c,fi,90}^0$ (kN)		6.5		
200	Steel Failure without lever arm - $V_{Rk,s,fi,90}^0$ (kN)			9.8	
	Steel Failure with lever arm - $M_{Rk,s,fi,90}^0$ (N.m)			20.9	
	Concrete edge failure - $V_{Rk,c,fi,90}^0$ (kN)			10.4	
300	Steel Failure without lever arm - $V_{Rk,s,fi,90}^0$ (kN)				15.3
	Steel Failure with lever arm - $M_{Rk,s,fi,90}^0$ (N.m)				40.7
	Concrete edge failure - $V_{Rk,c,fi,90}^0$ (kN)				15.9

Note: Bold values indicates limiting load. Data in table lists all possible failure mechanisms due to fire.

Note: Concrete edge failure values are based on 20 MPa concrete strength. For values in higher concrete strengths, please multiply $V_{Rk,c,fi,90}^0$ by the concrete compressive strength effect X_{vc} as follows;

f'_c (MPa)	20	30	40	50
X_{vc}	1	1.22	1.41	1.55

SpaTec™ Xtrem™

FIRE RATED MECHANICAL ANCHOR

Design Case

4

Fire resistance duration = 120 minutes

Table 4a Characteristic values of resistance to tension loads in 20 MPa to 50 MPa concrete strength for Fire resistance duration = 120 minutes

Anchor size, d _a		M10	M12	M16	M20
Drilled hole diam, d _h (mm)		15	18	24	28
Effective depth, h (mm)	Characteristic Resistance				
70	Steel Failure - N _{Rk,s,fi,120} (kN)	1.5			
	Pull-out failure concrete - N _{Rk,p,fi,120} (kN)	3.2			
	Concrete cone failure - N _{Rk,c,fi,120} (kN)	5.9			
80	Steel Failure - N _{Rk,s,fi,120} (kN)		2.2		
	Pull-out failure - N _{Rk,p,fi,120} (kN)		-		
	Concrete cone failure - N _{Rk,c,fi,120} (kN)		8.2		
100	Steel Failure - N _{Rk,s,fi,120} (kN)			4.1	
	Pull-out failure concrete - N _{Rk,p,fi,120} (kN)			-	
	Concrete cone failure - N _{Rk,c,fi,120} (kN)			14.4	
125	Steel Failure - N _{Rk,s,fi,120} (kN)				6.4
	Pull-out failure - N _{Rk,p,fi,120} (kN)				-
	Concrete cone failure - N _{Rk,c,fi,120} (kN)				25.2

Note: Bold values indicates limiting load. Data in table lists all possible failure mechanisms due to fire.

Table 4b Characteristic values of resistance to shear loads in 20 MPa concrete strength for Fire resistance duration = 120 minutes

Anchor size, d _a		M10	M12	M16	M20
Drilled hole diam, d _h (mm)		15	18	24	28
Edge distance, e _c (mm)	Characteristic Resistance				
140	Steel Failure without lever arm - V ⁰ _{Rk,s,fi,120} (kN)	1.5			
	Steel Failure with lever arm - M ⁰ _{Rk,s,fi,120} (N.m)	1.9			
	Concrete edge failure - V ⁰ _{Rk,c,fi,120} (kN)	3.9			
160	Steel Failure without lever arm - V ⁰ _{Rk,s,fi,120} (kN)		2.2		
	Steel Failure with lever arm - M ⁰ _{Rk,s,fi,120} (N.m)		3.4		
	Concrete edge failure - V ⁰ _{Rk,c,fi,120} (kN)		5.2		
200	Steel Failure without lever arm - V ⁰ _{Rk,s,fi,120} (kN)			4.1	
	Steel Failure with lever arm - M ⁰ _{Rk,s,fi,120} (N.m)			8.7	
	Concrete edge failure - V ⁰ _{Rk,c,fi,120} (kN)			8.3	
300	Steel Failure without lever arm - V ⁰ _{Rk,s,fi,120} (kN)				6.4
	Steel Failure with lever arm - M ⁰ _{Rk,s,fi,120} (N.m)				17.0
	Concrete edge failure - V ⁰ _{Rk,c,fi,120} (kN)				12.7

Note: Bold values indicates limiting load. Data in table lists all possible failure mechanisms due to fire.

Note: Concrete edge failure values are based on 20 MPa concrete strength. For values in higher concrete strengths, please multiply V⁰_{Rk,c,fi,120} by the concrete compressive strength effect X_{vc} as follows;

f _c (MPa)	20	30	40	50
X _{vc}	1	1.22	1.41	1.55

TruBolt™ Xtrem™

FIRE RATED MECHANICAL ANCHOR

[Back to index](#)

GENERAL INFORMATION

Performance Related	Material Specification	Installation Related

Product

A seismic certified heavy duty, torque controlled expansion anchor for permanent anchoring into concrete. Certified for seismic C1 & C2 applications.

Compliance

European Technical Assessment (option 1) - ETA-21/0973

Design according to:

- AS5216 (formerly TS101)
- AS1170.4 - Earthquake Actions
- EN1992-4 (formerly ETAG001 Annex C, E & TR045)
- NZS3101 (A3) Section 17 - Seismic Design C1 & C2

For optimised performance data, please use Ramset™ iExpert Anchor Software.

Benefits, Advantages and Features

Fire tested to TR020

- Fire rated performance up to 120 minutes
- Highest level of European approval for mechanical expansion anchors
- Approved for all directions (floor, wall, overhead)
- Maximum Tensile & Shear capacities in cracked concrete
- Zinc Plating 5µm
- Anchor diameters M10 to M20

Suitable for structural loads:

- "True to size" through fixture anchor

Improved security:

- Torque induced pull down closes gaps and induces preload.

Resistant to cyclic loading:

- Heavy duty sleeve with pull-down of fixture
- Anti rotation expansion sleeve

Fast installation:

- Anchor diameter equals hole diameter
- Shallow embedment depths



Principal Applications

- Anchoring into cracked & non cracked concrete
- Structural Steel columns & beams
- Road barrier hold down
- Bridge refurbishment
- Road & Rail tunnel construction
- Wall Plates
- Safety barriers
- Stadium seating
- Pallet racking
- Shallow embedment depths from 50mm
- Intended working life of the anchor of 50 years

Installation

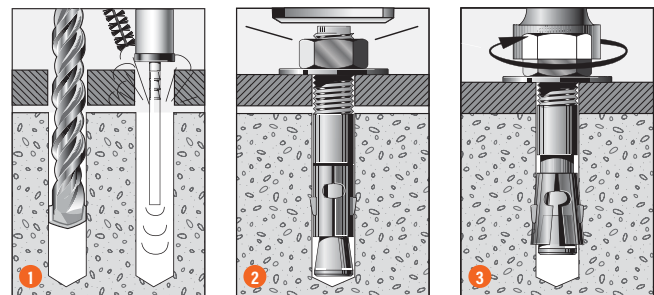

- Drill or core a hole to the recommended diameter (same as the TruBolt™ Xtrem™) and depth using the fixture as a template. Clean the hole thoroughly with a hole cleaning brush. Remove the debris with a hand pump, compressed air, or vacuum.
- Insert the anchor through the fixture and drive with a hammer until the washer contacts the fixture.
- Tighten the nut with a torque wrench to the specified assembly torque.

Fire Rated Anchoring Systems

TruBolt™ Xtrem™

FIRE RATED MECHANICAL ANCHOR

Fire Rated Anchoring Systems

Installation details for fire performance

Anchor size, d _b (mm)	Drilled hole diameter, d _h (mm)	Fixture hole diameter, d _f (mm)	Anchor effective depth, h (mm)	Depth of drill hole, h _i (mm)	Tightening torque, T _r (Nm)	Concrete substrate thickness, b _m (mm)	Optimum dimensions	
							Anchor* spacing, a _c (mm)	Edge** distance, e _c (mm)
M10	10	12	60	75	45	120	240	120
M12	12	14	70	90	60	140	280	140
M16	16	18	85	110	110	170	340	170
M20	20	22	100	130	160	200	400	200

*For performance based on smaller concrete substrate thickness or For anchor spacings less than the optimum, Refer to iExpert Anchor Software

** If the fire attack is from more than one side, the edge distance of the anchor has to be ≥ 300mm and ≥ 2xh.

*** Tightening Torque, T taken as 75Nm for stainless steel TruBolt Xtrem.

DESCRIPTION AND PART NUMBERS

Anchor size, d _b (mm)	Drilled hole diameter, d _h (mm)	Effective Length, L _e (mm)	Maximum Fixture Thickness, t _{fix,max} (mm)	ETA Designation Number		Part Number	
						Zn	S/S
M10	10	50	10	10x70/10	1	-	T10070SSX #
		65	5	10x85/25-5	D	T10085X	-
		75	15	10x95/35-15	2	-	T10095SSX
		80	20	10x100/40-20	F	T10100X	-
		85	25	10x105/45-25	3	-	T10105SSX
		100	40	10x120/60-40	G	T10120X	-
		110	50	10x130/70-50	4	-	T10130SSX
M12	12	70	20	12x95/20	1	-	T12095SSX #
		80	10	12x105/30-10	F	T12105X	-
		85	15	12x110/35-15	2	-	T12110SSX
		90	20	12x115/40-20	G	T12115X	-
		95	25	12x120/45-25	3	-	T12120SSX
		110	40	12x135/60-40	I	T12135X	-
		115	45	12x140/65-45	4	-	T12140SSX
M16	16	85	20	16x120/20	1	-	T16120SSX #
		105	20	16x140/40-20	2	-	T16140SSX
		110	25	16x145/45-25	I	T16145X	-
		135	50	16x170/70-50	K	T16170X	-
M20	20	130	30	20x170/30	K	T20170X	-
		160	60	20x200/60	M	T20200X	-

#Note: Effective depth not addressed in performance tables. Refer to iExpert for performance details. **NOTE: M20 not available in SS**

Effective depth, h (mm)

$$h = L_e - t$$

t = total thickness of material(s) being fixed

ENGINEERING PROPERTIES

Description	Zn		S/S	
	Material	Protection	Material	Protection
Bolt	Carbon Steel	M10 - M20: Zinc electroplated (>5µm) EN ISO 4042:2018	M10-M16 Stainless Steel A4	M10-M16 Stainless Steel A4, EN 10088.3:2014 + „coated
Clip	M10 - M20 Carbon Steel	M10 - M20: Zinc electroplated (>5µm) EN ISO 4042:2018	M10-M16 Stainless Steel A4	M10-M16 Stainless Steel A4, EN 10088.3:2014
Washer	M10 - M20 EN ISO 7092:200	M10 - M20: Zinc electroplated (>5µm) EN ISO 4042:2018	M10 - M16 EN ISO 7092:200	M10-M16 Stainless Steel A4
Nut	Steel, Strength class 8, ISO 898-2:2012	M10: Zinc electroplated (>5µm) EN ISO 4042:2018	M10-M16 Stainless Steel A4-80	M10-M16 Stainless Steel A4-80, EN ISO 3506-2:2019, coated
		M12 - M20: Zinc electroplated (>5µm) EN ISO 4042:2018		

TruBolt™ Xtrem™

FIRE RATED MECHANICAL ANCHOR

Design Case 1 Fire resistance duration = 30 minutes

Table 1a Characteristic values of resistance to tension loads in 20 MPa to 50 MPa concrete strength for Fire resistance duration = 30 minutes

Anchor size, d_b		M10		M12		M16		M20	
Drilled hole diam, d_h (mm)		10		12		16		20	
Effective depth, h (mm)	Characteristic Resistance	Zinc	Stainless Steel	Zinc	Stainless Steel	Zinc	Stainless Steel	Zinc	Stainless Steel
60	Steel Failure - $N_{Rk,s,fi,30}$ (kN)	2.8	9.9						
	Pull-out failure concrete - $N_{Rk,p,fi,30}$ (kN)	2.3	2.3						
	Concrete cone failure - $N_{Rk,c,fi,30}$ (kN)	5.0	5.0						
70	Steel Failure - $N_{Rk,s,fi,30}$ (kN)			3.6	9.2				
	Pull-out failure concrete - $N_{Rk,p,fi,30}$ (kN)			4.0	4.0				
	Concrete cone failure - $N_{Rk,c,fi,30}$ (kN)			7.4	7.4				
85	Steel Failure - $N_{Rk,s,fi,30}$ (kN)					6.6	16.1		
	Pull-out failure concrete - $N_{Rk,p,fi,30}$ (kN)					5.0	5.0		
	Concrete cone failure - $N_{Rk,c,fi,30}$ (kN)					12.0	12.0		
100	Steel Failure - $N_{Rk,s,fi,30}$ (kN)							10.4	-
	Pull-out failure concrete - $N_{Rk,p,fi,30}$ (kN)							7.5	-
	Concrete cone failure - $N_{Rk,c,fi,30}$ (kN)							18.0	-

NOTE: Bold values indicate limiting load. Data in table lists all possible failure mechanism due to fire.

Table 1b Characteristic values of resistance to shear loads in 20 MPa concrete strength for Fire resistance duration = 30 minutes

Anchor size, d_b		M10		M12		M16		M20	
Drilled hole diam, d_h (mm)		10		12		16		20	
Edge distance, e_c (mm)	Characteristic Resistance	Zinc	Stainless Steel	Zinc	Stainless Steel	Zinc	Stainless Steel	Zinc	Stainless Steel
120	Steel Failure without lever arm - $V_{Rk,s,fi,30}^0$ (kN)	2.8	9.9						
	Steel Failure with lever arm - $M_{Rk,s,fi,30}^0$ (N.m)	3.5	12.7						
	Concrete edge failure - $V_{Rk,c,fi,30}^0$ (kN)	3.3	3.3						
140	Steel Failure without lever arm - $V_{Rk,s,fi,30}^0$ (kN)			3.6	9.2				
	Steel Failure with lever arm - $M_{Rk,s,fi,30}^0$ (N.m)			5.5	14.4				
	Concrete edge failure - $V_{Rk,c,fi,30}^0$ (kN)			4.6	4.6				
170	Steel Failure without lever arm - $V_{Rk,s,fi,30}^0$ (kN)					6.6	16.1		
	Steel Failure with lever arm - $M_{Rk,s,fi,30}^0$ (N.m)					14.1	34.1		
	Concrete edge failure - $V_{Rk,c,fi,30}^0$ (kN)					7.0	7.0		
200	Steel Failure without lever arm - $V_{Rk,s,fi,30}^0$ (kN)							10.4	-
	Steel Failure with lever arm - $M_{Rk,s,fi,30}^0$ (N.m)							27.5	-
	Concrete edge failure - $V_{Rk,c,fi,30}^0$ (kN)							9.6	-

NOTE: Bold values indicate limiting load. Data in table lists all possible failure mechanism due to fire.

Note: Concrete edge failure values are based on 20 MPa concrete strength. For values in higher concrete strengths, please multiply $V_{Rk,c,fi,30}^0$ by the concrete compressive strength effect X_{vc} as follows;

f'_c (MPa)	20	30	40	50
X_{vc}	1	1.22	1.41	1.55

TruBolt™ Xtrem™

FIRE RATED MECHANICAL ANCHOR

Fire Rated Anchoring Systems

Design Case 2 Fire resistance duration = 60 minutes

Table 2a Characteristic values of resistance to tension loads in 20 MPa to 50 MPa concrete strength for Fire resistance duration = 90 minutes

Anchor size, d _b		M10		M12		M16		M20	
Drilled hole diam, d _h (mm)		10		12		16		20	
Effective depth, h (mm)	Characteristic Resistance	Zinc	Stainless Steel	Zinc	Stainless Steel	Zinc	Stainless Steel	Zinc	Stainless Steel
60	Steel Failure - N _{Rk,s,fi,60} (kN)	2.3	6.3						
	Pull-out failure concrete - N _{Rk,p,fi,60} (kN)	2.3	2.3						
	Concrete cone failure - N _{Rk,c,fi,60} (kN)	5.0	5.0						
70	Steel Failure - N _{Rk,s,fi,60} (kN)			3.1	6.5				
	Pull-out failure concrete - N _{Rk,p,fi,60} (kN)			4.0	4.0				
	Concrete cone failure - N _{Rk,c,fi,60} (kN)			7.4	7.4				
85	Steel Failure - N _{Rk,s,fi,60} (kN)					5.7	11.3		
	Pull-out failure concrete - N _{Rk,p,fi,60} (kN)					5.0	5.0		
	Concrete cone failure - N _{Rk,c,fi,60} (kN)					12.0	12.0		
100	Steel Failure - N _{Rk,s,fi,90} (kN)							9.0	-
	Pull-out failure concrete - N _{Rk,p,fi,60} (kN)							7.5	-
	Concrete cone failure - N _{Rk,c,fi,60} (kN)							18.0	-

NOTE: Bold values indicate limiting load. Data in table lists all possible failure mechanism due to fire.

Table 2b Characteristic values of resistance to shear loads in 20 MPa concrete strength for Fire resistance duration = 60 minutes

Anchor size, d _b		M10		M12		M16		M20	
Drilled hole diam, d _h (mm)		10		12		16		20	
Edge distance, e _c (mm)	Characteristic Resistance	Zinc	Stainless Steel	Zinc	Stainless Steel	Zinc	Stainless Steel	Zinc	Stainless Steel
120	Steel Failure without lever arm - V ⁰ _{Rk,s,fi,60} (kN)	2.3	6.3						
	Steel Failure with lever arm - M ⁰ _{Rk,s,fi,60} (N.m)	2.9	8.1						
	Concrete edge failure - V ⁰ _{Rk,c,fi,60} (kN)	3.3	3.3						
140	Steel Failure without lever arm - V ⁰ _{Rk,s,fi,60} (kN)			3.1	6.5				
	Steel Failure with lever arm - M ⁰ _{Rk,s,fi,60} (N.m)			4.8	10.1				
	Concrete edge failure - V ⁰ _{Rk,c,fi,60} (kN)			4.6	4.6				
170	Steel Failure without lever arm - V ⁰ _{Rk,s,fi,60} (kN)					5.7	11.3		
	Steel Failure with lever arm - M ⁰ _{Rk,s,fi,60} (N.m)					12.2	23.9		
	Concrete edge failure - V ⁰ _{Rk,c,fi,60} (kN)					7.0	7.0		
200	Steel Failure without lever arm - V ⁰ _{Rk,s,fi,60} (kN)							9.0	-
	Steel Failure with lever arm - M ⁰ _{Rk,s,fi,60} (N.m)							23.8	-
	Concrete edge failure - V ⁰ _{Rk,c,fi,60} (kN)							9.6	-

NOTE: Bold values indicate limiting load. Data in table lists all possible failure mechanism due to fire.

Note: Concrete edge failure values are based on 20 MPa concrete strength. For values in higher concrete strengths, please multiply V⁰_{Rk,c,fi,60} by the concrete compressive strength effect X_{vc} as follows;

f _c (MPa)	20	30	40	50
X _{vc}	1	1.22	1.41	1.55

TruBolt™ Xtrem™

FIRE RATED MECHANICAL ANCHOR

Design Case

3

Fire resistance duration = 90 minutes

Table 3a Characteristic values of resistance to tension loads in 20 MPa to 50 MPa concrete strength for Fire resistance duration = 90 minutes

Anchor size, d _b		M10		M12		M16		M20	
Drilled hole diam, d _h (mm)		10		12		16		20	
Effective depth, h (mm)	Characteristic Resistance	Zinc	Stainless Steel	Zinc	Stainless Steel	Zinc	Stainless Steel	Zinc	Stainless Steel
60	Steel Failure - N _{Rk,s,f,90} (kN)	1.8	2.6						
	Pull-out failure concrete - N _{Rk,p,f,90} (kN)	2.3	2.3						
	Concrete cone failure - N _{Rk,c,f,90} (kN)	5.0	5.0						
70	Steel Failure - N _{Rk,s,f,90} (kN)			2.6	3.7				
	Pull-out failure concrete - N _{Rk,p,f,90} (kN)			4.0	4.0				
	Concrete cone failure - N _{Rk,c,f,90} (kN)			7.4	7.4				
85	Steel Failure - N _{Rk,s,f,90} (kN)					4.9	6.5		
	Pull-out failure concrete - N _{Rk,p,f,90} (kN)					5.0	5.0		
	Concrete cone failure - N _{Rk,c,f,90} (kN)					12.0	12.0		
100	Steel Failure - N _{Rk,s,f,90} (kN)							7.6	-
	Pull-out failure concrete - N _{Rk,p,f,90} (kN)							7.5	-
	Concrete cone failure - N _{Rk,c,f,90} (kN)							18.0	-

NOTE: Bold values indicate limiting load. Data in table lists all possible failure mechanism due to fire.

Table 3b Characteristic values of resistance to shear loads in 20 MPa concrete strength for Fire resistance duration = 90 minutes

Anchor size, d _b		M10		M12		M16		M20	
Drilled hole diam, d _h (mm)		10		12		16		20	
Edge distance, e _c (mm)	Characteristic Resistance	Zinc	Stainless Steel	Zinc	Stainless Steel	Zinc	Stainless Steel	Zinc	Stainless Steel
120	Steel Failure without lever arm - V ⁰ _{Rk,s,f,90} (kN)	1.8	2.6						
	Steel Failure with lever arm - M ⁰ _{Rk,s,f,90} (N.m)	2.3	3.3						
	Concrete edge failure - V ⁰ _{Rk,c,f,90} (kN)	3.3	3.3						
140	Steel Failure without lever arm - V ⁰ _{Rk,s,f,90} (kN)			2.6	3.7				
	Steel Failure with lever arm - M ⁰ _{Rk,s,f,90} (N.m)			4.0	5.7				
	Concrete edge failure - V ⁰ _{Rk,c,f,90} (kN)			4.6	4.6				
170	Steel Failure without lever arm - V ⁰ _{Rk,s,f,90} (kN)					4.9	6.5		
	Steel Failure with lever arm - M ⁰ _{Rk,s,f,90} (N.m)					10.3	13.8		
	Concrete edge failure - V ⁰ _{Rk,c,f,90} (kN)					7.0	7.0		
200	Steel Failure without lever arm - V ⁰ _{Rk,s,f,90} (kN)							7.6	-
	Steel Failure with lever arm - M ⁰ _{Rk,s,f,90} (N.m)							20.1	-
	Concrete edge failure - V ⁰ _{Rk,c,f,90} (kN)							9.6	-

NOTE: Bold values indicate limiting load. Data in table lists all possible failure mechanism due to fire.

Note: Concrete edge failure values are based on 20 MPa concrete strength. For values in higher concrete strengths, please multiply V⁰_{Rk,c,f,90} by the concrete compressive strength effect X_{vc}, as follows;

f _c (MPa)	20	30	40	50
X _{vc}	1	1.22	1.41	1.55

TruBolt™ Xtrem™

FIRE RATED MECHANICAL ANCHOR

Fire Rated Anchoring Systems

Design Case **4**

Fire resistance duration = 120 minutes

Table 4a Characteristic values of resistance to tension loads in 20 MPa to 50 MPa concrete strength for Fire resistance duration = 120 minutes

Anchor size, d _b		M10		M12		M16		M20	
Drilled hole diam, d _h (mm)		10		12		16		20	
Effective depth, h (mm)	Characteristic Resistance	Zinc	Stainless Steel	Zinc	Stainless Steel	Zinc	Stainless Steel	Zinc	Stainless Steel
60	Steel Failure - N _{Rk,s,fi,120} (kN)	1.6	0.8						
	Pull-out failure concrete - N _{Rk,p,fi,120} (kN)	1.8	1.8						
	Concrete cone failure - N _{Rk,c,fi,120} (kN)	4.0	4.0						
70	Steel Failure - N _{Rk,s,fi,90} (kN)			2.4	2.3				
	Pull-out failure concrete - N _{Rk,p,fi,120} (kN)			3.2	3.2				
	Concrete cone failure - N _{Rk,c,fi,120} (kN)			5.9	5.9				
85	Steel Failure - N _{Rk,s,fi,120} (kN)					4.4	4.1		
	Pull-out failure concrete - N _{Rk,p,fi,120} (kN)					4.0	4.0		
	Concrete cone failure - N _{Rk,c,fi,120} (kN)					9.6	9.6		
100	Steel Failure - N _{Rk,s,fi,90} (kN)							6.9	-
	Pull-out failure concrete - N _{Rk,p,fi,120} (kN)							6.0	-
	Concrete cone failure - N _{Rk,c,fi,120} (kN)							14.4	-

NOTE: Bold values indicate limiting load. Data in table lists all possible failure mechanism due to fire.

Table 4b Characteristic values of resistance to shear loads in 20 MPa concrete strength for Fire resistance duration = 120 minutes

Anchor size, d _b		M10		M12		M16		M20	
Drilled hole diam, d _h (mm)		10		12		16		20	
Edge distance, e _c (mm)	Characteristic Resistance	Zinc	Stainless Steel	Zinc	Stainless Steel	Zinc	Stainless Steel	Zinc	Stainless Steel
120	Steel Failure without lever arm - V ⁰ _{Rk,s,fi,120} (kN)	1.6	0.8						
	Steel Failure with lever arm - M ⁰ _{Rk,s,fi,120} (N.m)	2.0	1.0						
	Concrete edge failure - V ⁰ _{Rk,c,fi,120} (kN)	3.3	3.3						
140	Steel Failure without lever arm - V ⁰ _{Rk,s,fi,120} (kN)			2.4	2.3				
	Steel Failure with lever arm - M ⁰ _{Rk,s,fi,120} (N.m)			3.7	3.6				
	Concrete edge failure - V ⁰ _{Rk,c,fi,120} (kN)			4.6	4.6				
170	Steel Failure without lever arm - V ⁰ _{Rk,s,fi,120} (kN)					4.4	4.1		
	Steel Failure with lever arm - M ⁰ _{Rk,s,fi,120} (N.m)					9.3	8.7		
	Concrete edge failure - V ⁰ _{Rk,c,fi,120} (kN)					7.0	7.0		
200	Steel Failure without lever arm - V ⁰ _{Rk,s,fi,120} (kN)							6.9	-
	Steel Failure with lever arm - M ⁰ _{Rk,s,fi,120} (N.m)							18.2	-
	Concrete edge failure - V ⁰ _{Rk,c,fi,120} (kN)							9.6	-

NOTE: Bold values indicate limiting load. Data in table lists all possible failure mechanism due to fire.

Note: Concrete edge failure values are based on 20 MPa concrete strength. For values in higher concrete strengths, please multiply V⁰_{Rk,c,fi,120} by the concrete compressive strength effect X_{vc}, as follows;

f _c (MPa)	20	30	40	50
X _{vc}	1	1.22	1.41	1.55

AnkaScrew™ Xtrem™

FIRE RATED MECHANICAL ANCHOR

[Back to index](#)

GENERAL INFORMATION

Performance Related	Material	Installation Related

Product

A seismic certified heavy duty screw-in anchor for permanent anchoring into concrete. Certified for seismic C1 & C2 applications.



Compliance

European Technical Assessment (option1) - ETA-20/0731

Design According to:

- AS5216 (formerly TS101)
- AS1170.4 - Earthquake Actions
- EN1992-4 (formerly ETAG001 Annex C, E & TR045)
- NZS3101 (A3) Section 17 - Seismic Design C1 & C2



Benefits, Advantages and Features

Fire tested to TR020

- Fire rated performance up to 120 minutes
- Highest level of European assessment for mechanical screw-in anchors
- Approved for all directions (floor, wall, overhead)
- Maximum Tensile & Shear capacities in cracked concrete
- Zinc Plating 5µm
- Anchor diameters 6mm to 12mm

Fast and easy to use:

- Install, simply screws into hole.
- Remove, leaving an empty hole.

Close to edge and for close anchor spacing:

- Does not expand and burst concrete.

Principal Applications

- Anchoring into cracked & non cracked concrete
- Steel framing
- Mechanical services
- Pallet racking
- Safety barriers
- Conveyors
- Hand rails
- Bottom plates

Installation

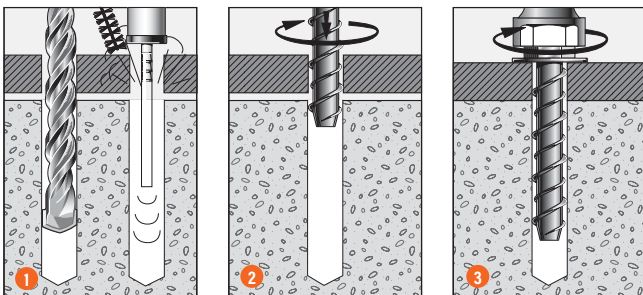

- Drill hole to correct diameter and depth. Important: Use **Ramset™ Dustless Drilling System** to ensure holes are clean. Alternatively, clean thoroughly with brush and remove debris by way of vacuum or hand pump, compressed air etc.
- Using a socket wrench, screw the AnkaScrew™ Xtrem™ into the hole using slight pressure until the self tapping action starts.
- Tighten the AnkaScrew™ Xtrem™ until flush with fixture. If resistance is experienced when tightening, unscrew anchor one turn and re-tighten. Ensure not to over tighten. Refer to tightening torque for limitations.

Fire Rated Anchoring Systems

AnkaScrew™ Xtrem™

FIRE RATED MECHANICAL ANCHOR

Fire Rated Anchoring Systems

Installation details for fire performance

Anchor size, d_b (mm)	Drilled hole diameter, d_h (mm)	Fixture hole diameter, d_f (mm)	Anchor effective depth, h (mm)	Depth of drill hole, h_i (mm)	Tightening torque, T_t (Nm)	Concrete substrate thickness, b_m (mm) ***	Optimum dimensions	
							Anchor* spacing, a_c (mm)	Edge** distance, e_c (mm)
6	6	8	44	60	10	90	176	88
8	8	12	52	75	20	105	208	104
10	10	14	68	95	40	136	272	136
12	12	16	80	110	60	160	320	160

* For anchor spacings less than the optimum, please contact your local Ramset Engineer.

** If the fire attack is from more than one side, the edge distance of the anchor has to be $\geq 300\text{mm}$ and $\geq 2x_h$.

***Note: For performance based on smaller concrete substrate thickness, refer to iExpert Anchor Software or Ramset™ Engineer.

DESCRIPTION AND PART NUMBERS

Anchor size, d_b (mm)	Drilled hole diameter, d_h (mm)	Effective Length, L_e (mm)	Maximum Fixture Thickness, $t_{fix,max}$ (mm)	AnkaScrew™ Xtrem™ Description	Part Number
6	6	71	19	6mmx80mm zinc	AS06080X
8	8	67	15	8mmx80mm zinc	AS08080X
10	10	88	20	10mmx100mm zinc	AS10100X
12	12	95	15	12mmx110mm zinc	AS12110X
		135	55	12mmx150mm zinc	AS12150X

Effective depth, h (mm)

$$h = L_e - t$$

t = total thickness of material(s) being fixed

ENGINEERING PROPERTIES

Anchor size, d_b (mm)	Minimum cross sectional diameter (mm)	Stress area, A_s (mm ²)	Yield strength, f_y (MPa)	UTS, F_u (Mpa)
6	5.1	20.4	560	700
8	7.1	39.6	560	700
10	9.1	65.0	560	700
12	11.1	96.8	560	700

AnkaScrew™ Xtrem™

FIRE RATED MECHANICAL ANCHOR

Design Case

1 Fire resistance duration = 30 minutes

Table 1a Characteristic values of resistance to tension loads in 20 MPa to 50 MPa concrete strength for Fire resistance duration = 30 minutes

Anchor size, d_b		M6	M8	M10	M12
Drilled hole diam, d_h (mm)		6	8	10	12
Effective depth, h (mm)	Characteristic Resistance				
44	Steel Failure - $N_{Rk,s,fi,30}$ (kN)	0.9			
	Pull-out failure concrete - $N_{Rk,p,fi,30}$ (kN)	1.0			
	Concrete cone failure - $N_{Rk,c,fi,30}$ (kN)	2.2			
52	Steel Failure - $N_{Rk,s,fi,30}$ (kN)		2.4		
	Pull-out failure concrete - $N_{Rk,p,fi,30}$ (kN)		3.0		
	Concrete cone failure - $N_{Rk,c,fi,30}$ (kN)		3.4		
68	Steel Failure - $N_{Rk,s,fi,30}$ (kN)			4.4	
	Pull-out failure concrete - $N_{Rk,p,fi,30}$ (kN)			4.8	
	Concrete cone failure - $N_{Rk,c,fi,30}$ (kN)			6.6	
80	Steel Failure - $N_{Rk,s,fi,30}$ (kN)				7.3
	Pull-out failure concrete - $N_{Rk,p,fi,30}$ (kN)				6.2
	Concrete cone failure - $N_{Rk,c,fi,30}$ (kN)				9.9

NOTE: Bold values indicate limiting load. Data in table lists all possible failure mechanism due to fire.

Table 1b Characteristic values of resistance to shear loads in 20 MPa concrete strength for Fire resistance duration = 30 minutes

Anchor size, d_b		M6	M8	M10	M12
Drilled hole diam, d_h (mm)		6	8	10	12
Edge distance, e_c (mm)	Characteristic Resistance				
88	Steel Failure without lever arm - $V_{Rk,s,fi,30}^0$ (kN)	0.9			
	Steel Failure with lever arm - $M_{Rk,s,fi,30}^0$ (N.m)	0.7			
	Concrete edge failure - $V_{Rk,c,fi,30}^0$ (kN)	1.7			
104	Steel Failure without lever arm - $V_{Rk,s,fi,30}^0$ (kN)		2.4		
	Steel Failure with lever arm - $M_{Rk,s,fi,30}^0$ (N.m)		2.4		
	Concrete edge failure - $V_{Rk,c,fi,30}^0$ (kN)		2.5		
136	Steel Failure without lever arm - $V_{Rk,s,fi,30}^0$ (kN)			4.4	
	Steel Failure with lever arm - $M_{Rk,s,fi,30}^0$ (N.m)			5.9	
	Concrete edge failure - $V_{Rk,c,fi,30}^0$ (kN)			4.1	
160	Steel Failure without lever arm - $V_{Rk,s,fi,30}^0$ (kN)				7.3
	Steel Failure with lever arm - $M_{Rk,s,fi,30}^0$ (N.m)				12.3
	Concrete edge failure - $V_{Rk,c,fi,30}^0$ (kN)				5.8

NOTE: Bold values indicate limiting load for conditions without lever arm. Data in table lists all possible failure mechanism due to fire.

Note: Concrete edge failure values are based on 20 MPa concrete strength. For values in higher concrete strengths, please multiply $V_{Rk,c,fi,30}^0$ by the concrete compressive strength effect X_{vc} as follows;

f'_c (MPa)	20	30	40	50
X_{vc}	1	1.22	1.41	1.55

AnkaScrew™ Xtrem™

FIRE RATED MECHANICAL ANCHOR

Fire Rated Anchoring Systems

Design Case 2 Fire resistance duration = 60 minutes

Table 2a Characteristic values of resistance to tension loads in 20 MPa to 50 MPa concrete strength for Fire resistance duration = 60 minutes

Anchor size, d_b		M6	M8	M10	M12
Drilled hole diam, d_r (mm)		6	8	10	12
Effective depth, h (mm)	Characteristic Resistance				
44	Steel Failure - $N_{Rk,s,fi,60}$ (kN)	0.8			
	Pull-out failure concrete - $N_{Rk,p,fi,60}$ (kN)	1.0			
	Concrete cone failure - $N_{Rk,c,fi,60}$ (kN)	2.2			
52	Steel Failure - $N_{Rk,s,fi,60}$ (kN)		1.7		
	Pull-out failure concrete - $N_{Rk,p,fi,60}$ (kN)		3.0		
	Concrete cone failure - $N_{Rk,c,fi,60}$ (kN)		3.4		
68	Steel Failure - $N_{Rk,s,fi,60}$ (kN)			3.3	
	Pull-out failure concrete - $N_{Rk,p,fi,60}$ (kN)			4.8	
	Concrete cone failure - $N_{Rk,c,fi,60}$ (kN)			6.6	
80	Steel Failure - $N_{Rk,s,fi,60}$ (kN)				5.8
	Pull-out failure concrete - $N_{Rk,p,fi,60}$ (kN)				6.2
	Concrete cone failure - $N_{Rk,c,fi,60}$ (kN)				9.9

NOTE: Bold values indicate limiting load. Data in table lists all possible failure mechanism due to fire.

Table 2b Characteristic values of resistance to shear loads in 20 MPa concrete strength for Fire resistance duration = 60 minutes

Anchor size, d_b		M6	M8	M10	M12
Drilled hole diam, d_r (mm)		6	8	10	12
Edge distance, e_c (mm)	Characteristic Resistance				
88	Steel Failure without lever arm - $V_{Rk,s,fi,60}^0$ (kN)	0.8			
	Steel Failure with lever arm - $M_{Rk,s,fi,60}^0$ (N.m)	0.6			
	Concrete edge failure - $V_{Rk,c,fi,60}^0$ (kN)	1.7			
104	Steel Failure without lever arm - $V_{Rk,s,fi,60}^0$ (kN)		1.7		
	Steel Failure with lever arm - $M_{Rk,s,fi,60}^0$ (N.m)		1.8		
	Concrete edge failure - $V_{Rk,c,fi,60}^0$ (kN)		2.5		
136	Steel Failure without lever arm - $V_{Rk,s,fi,60}^0$ (kN)			3.3	
	Steel Failure with lever arm - $M_{Rk,s,fi,60}^0$ (N.m)			4.5	
	Concrete edge failure - $V_{Rk,c,fi,60}^0$ (kN)			4.1	
160	Steel Failure without lever arm - $V_{Rk,s,fi,60}^0$ (kN)				5.8
	Steel Failure with lever arm - $M_{Rk,s,fi,60}^0$ (N.m)				9.7
	Concrete edge failure - $V_{Rk,c,fi,60}^0$ (kN)				5.8

NOTE: Bold values indicate limiting load for conditions without lever arm. Data in table lists all possible failure mechanism due to fire.

Note: Concrete edge failure values are based on 20 MPa concrete strength. For values in higher concrete strengths, please multiply $V_{Rk,c,fi,60}^0$ by the concrete compressive strength effect X_{ve} , as follows;

f'_c (MPa)	20	30	40	50
X_{ve}	1	1.22	1.41	1.55

AnkaScrew™ Xtrem™

FIRE RATED MECHANICAL ANCHOR

Design Case 3 Fire resistance duration = 90 minutes

Table 3a Characteristic values of resistance to tension loads in 20 MPa to 50 MPa concrete strength for Fire resistance duration = 90 minutes

Anchor size, d_b		M6	M8	M10	M12
Drilled hole diam, d_h (mm)		6	8	10	12
Effective depth, h (mm)	Characteristic Resistance				
44	Steel Failure - $N_{Rk,s,fi,90}$ (kN)	0.6			
	Pull-out failure concrete - $N_{Rk,p,fi,90}$ (kN)	1.0			
	Concrete cone failure - $N_{Rk,c,fi,90}$ (kN)	2.2			
52	Steel Failure - $N_{Rk,s,fi,90}$ (kN)		1.1		
	Pull-out failure concrete - $N_{Rk,p,fi,90}$ (kN)		3.0		
	Concrete cone failure - $N_{Rk,c,fi,90}$ (kN)		3.4		
68	Steel Failure - $N_{Rk,s,fi,90}$ (kN)			2.3	
	Pull-out failure concrete - $N_{Rk,p,fi,90}$ (kN)			4.8	
	Concrete cone failure - $N_{Rk,c,fi,90}$ (kN)			6.6	
80	Steel Failure - $N_{Rk,s,fi,90}$ (kN)				4.2
	Pull-out failure concrete - $N_{Rk,p,fi,90}$ (kN)				6.2
	Concrete cone failure - $N_{Rk,c,fi,90}$ (kN)				9.9

NOTE: Bold values indicate limiting load. Data in table lists all possible failure mechanism due to fire.

Table 3b Characteristic values of resistance to shear loads in 20 MPa concrete strength for Fire resistance duration = 90 minutes

Anchor size, d_b		M6	M8	M10	M12
Drilled hole diam, d_h (mm)		6	8	10	12
Edge distance, e_c (mm)	Characteristic Resistance				
88	Steel Failure without lever arm - $V_{Rk,s,fi,90}^0$ (kN)	0.6			
	Steel Failure with lever arm - $M_{Rk,s,fi,90}^0$ (N.m)	0.5			
	Concrete edge failure - $V_{Rk,c,fi,90}^0$ (kN)	1.7			
104	Steel Failure without lever arm - $V_{Rk,s,fi,90}^0$ (kN)		1.1		
	Steel Failure with lever arm - $M_{Rk,s,fi,90}^0$ (N.m)		1.2		
	Concrete edge failure - $V_{Rk,c,fi,90}^0$ (kN)		2.5		
136	Steel Failure without lever arm - $V_{Rk,s,fi,90}^0$ (kN)			2.3	
	Steel Failure with lever arm - $M_{Rk,s,fi,90}^0$ (N.m)			3.0	
	Concrete edge failure - $V_{Rk,c,fi,90}^0$ (kN)			4.1	
160	Steel Failure without lever arm - $V_{Rk,s,fi,90}^0$ (kN)				4.2
	Steel Failure with lever arm - $M_{Rk,s,fi,90}^0$ (N.m)				7.0
	Concrete edge failure - $V_{Rk,c,fi,90}^0$ (kN)				5.8

NOTE: Bold values indicate limiting load for conditions without lever arm. Data in table lists all possible failure mechanism due to fire.

Note: Concrete edge failure values are based on 20 MPa concrete strength. For values in higher concrete strengths, please multiply $V_{Rk,c,fi,90}^0$ by the concrete compressive strength effect X_{vc} as follows;

f'_c (MPa)	20	30	40	50
X_{vc}	1	1.22	1.41	1.55

AnkaScrew™ Xtrem™

FIRE RATED MECHANICAL ANCHOR

Fire Rated Anchoring Systems

Design Case 4 Fire resistance duration = 120 minutes

Table 4a Characteristic values of resistance to tension loads in 20 MPa to 50 MPa concrete strength for Fire resistance duration = 120 minutes

Anchor size, d_b		M6	M8	M10	M12
Drilled hole diam, d_h (mm)		6	8	10	12
Effective depth, h (mm)	Characteristic Resistance				
44	Steel Failure - $N_{Rk,s,fi,120}$ (kN)	0.4			
	Pull-out failure concrete - $N_{Rk,p,fi,120}$ (kN)	0.8			
	Concrete cone failure - $N_{Rk,c,fi,120}$ (kN)	1.8			
52	Steel Failure - $N_{Rk,s,fi,120}$ (kN)		0.7		
	Pull-out failure concrete - $N_{Rk,p,fi,120}$ (kN)		2.4		
	Concrete cone failure - $N_{Rk,c,fi,120}$ (kN)		2.7		
68	Steel Failure - $N_{Rk,s,fi,120}$ (kN)			1.7	
	Pull-out failure concrete - $N_{Rk,p,fi,120}$ (kN)			3.9	
	Concrete cone failure - $N_{Rk,c,fi,120}$ (kN)			5.3	
80	Steel Failure - $N_{Rk,s,fi,120}$ (kN)				3.4
	Pull-out failure concrete - $N_{Rk,p,fi,120}$ (kN)				4.9
	Concrete cone failure - $N_{Rk,c,fi,120}$ (kN)				7.9

NOTE: Bold values indicate limiting load. Data in table lists all possible failure mechanism due to fire.

Table 4b Characteristic values of resistance to shear loads in 20 MPa concrete strength for Fire resistance duration = 120 minutes

Anchor size, d_b		M6	M8	M10	M12
Drilled hole diam, d_h (mm)		6	8	10	12
Edge distance, e_c (mm)	Characteristic Resistance				
88	Steel Failure without lever arm - $V_{Rk,s,fi,120}^0$ (kN)	0.4			
	Steel Failure with lever arm - $M_{Rk,s,fi,120}^0$ (N.m)	0.3			
	Concrete edge failure - $V_{Rk,c,fi,120}^0$ (kN)	1.4			
104	Steel Failure without lever arm - $V_{Rk,s,fi,120}^0$ (kN)		0.7		
	Steel Failure with lever arm - $M_{Rk,s,fi,120}^0$ (N.m)		0.9		
	Concrete edge failure - $V_{Rk,c,fi,120}^0$ (kN)		2.0		
136	Steel Failure without lever arm - $V_{Rk,s,fi,120}^0$ (kN)			1.7	
	Steel Failure with lever arm - $M_{Rk,s,fi,120}^0$ (N.m)			2.3	
	Concrete edge failure - $V_{Rk,c,fi,120}^0$ (kN)			3.3	
160	Steel Failure without lever arm - $V_{Rk,s,fi,120}^0$ (kN)				3.4
	Steel Failure with lever arm - $M_{Rk,s,fi,120}^0$ (N.m)				5.7
	Concrete edge failure - $V_{Rk,c,fi,120}^0$ (kN)				4.6

NOTE: Bold values indicate limiting load for conditions without lever arm. Data in table lists all possible failure mechanism due to fire.

Note: Concrete edge failure values are based on 20 MPa concrete strength. For values in higher concrete strengths, please multiply $V_{Rk,c,fi,120}^0$ by the concrete compressive strength effect X_{ve} , as follows;

f'_c (MPa)	20	30	40	50
X_{ve}	1	1.22	1.41	1.55

EPCON™ C8 Xtrem™

FIRE RATED CHEMICAL ANCHOR

[Back to index](#)

GENERAL INFORMATION

Performance Related	Installation Related

Product
 EPCON™ C8 Xtrem™ is a High Performance Pure Epoxy Anchoring adhesive for use in Cracked and Non-Cracked concrete. For structures subject to external exposure, permanently damp or aggressive conditions.



Compliance
 European Technical Assessment (option 1) - ETA-10/0309
 Design according to:

- AS5216 (formerly TS101)
- EN1992-4 (formerly ETAG001 Annex C, E & TR045)
- Use enclosed data for simplified calculation method
- NZS3101 (A3) Section 17 - Seismic Design C1 & C2

Use Ramset™ iExpert Anchor Software for optimised calculation or where a greater range of anchor layout detail is needed



Benefits, Advantages and Features

Fire tested to European Fire Standards

- CSTB Fire test Report no 26007642/b
- For Wall to Slab connection with reinforcement bar
- For Beam frame reinforcement

Greater productivity:

- Anchors in dry, damp, wet or flooded holes
- No weather delays
- Fast, easy dispensing with high flow mixer

Greater security:

- Highest performance in cracked concrete
- Rated for sustained loading

Versatile

- Anchors all stud & bar diameters in all directions
- Oversized holes*
- Anchors in carbide drilled and diamond cored holes*
- For tropical and Cold weather conditions

Greater safety:

- Low odour

Fire Rated : Refer Fire rated anchoring section

Principal Applications

- Anchoring into cracked & non cracked concrete
- Road barrier hold down bolts
- Bridge refurbishment
- Road & Rail tunnel construction
- Reinforcing bar from 10 to 32mm
- Starter Bars
- Threaded studs from M8 to M30
- Threaded Stud material: Zn, A4 316, HCR steels
- Threaded Stud material: 5.8, 8.8, 10.9 grade

Recommended Installation Temperatures

	Minimum	Maximum
Substrate	5°C	40°C
Adhesive	5°C	40°C

Load should not be applied to anchor until the chemical has sufficiently cured as specified.

Service Temperature Limits

-40°C to 80°C

Setting Times EPCON™ C8 Xtrem™

Temperature of base material	Gel Time	Curing time in dry concrete	Curing time in wet concrete
5°C - 9°C	20 min	30 h	60 h
10°C - 19°C	14 min	23 h	46 h
20°C - 24°C	11 min	16 h	32 h
25°C - 29°C	8 min	12 h	24 h
30°C - 39°C	5 min	8 h	16 h
40°C	5 min	6 h	12 h

Note

*Performance of cored & oversized holes was not included in the ETAG test program and therefore is based on testing conducted at Ramset™ Product Engineering Laboratory.

Installation

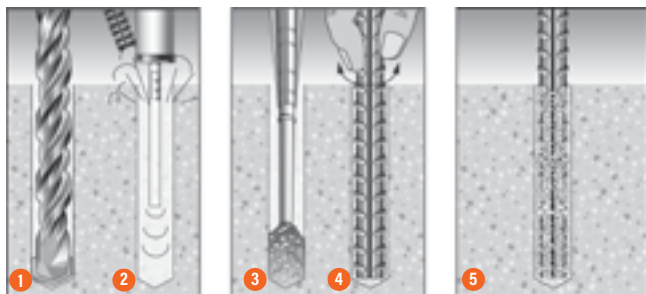

1. Drill or core hole to specified diameter and depth
2. **Important:** Use Ramset™ Dustless Drilling System to ensure holes are clean. Alternatively, clean dust and debris from hole with stiff wire or nylon brush and blower in the following sequence: blow x 2, brush x 2, blow x 2.
3. Screw mixing nozzle onto cartridge and dispense 2-3 trigger pulls of adhesive to waste until colour is grey with no streaks
4. Insert tip of nozzle to bottom of hole and dispense adhesive
5. Fill hole to about 2/3 full
6. Insert reinforcing bar with rotating motion to release trapped air
7. Wait until adhesive has fully cured before loading (see Working Time / Loading Time chart)
8. Clean up with Acetone

EPCON™ C8 Xtrem™

FIRE RATED CHEMICAL ANCHOR

Fire Rated Anchoring Systems

Installation Details

EPCON™ C8 Xtrem™ with Reinforcing Bar

Anchor size, d_b (mm)	Drilled hole diameter, d_h (mm)
10	12
12	15
16	20
20	25
24	30
25	30
32	40
40	50

DESCRIPTION AND PART NUMBERS

Description	Cartridge Size	Part No.
EPCON™ C8 Xtrem™	450 ml	C8-450

ENGINEERING PROPERTIES

Typical Engineering Properties of Grade 500 Reinforcing Bar

Rebar Size	10	12	16	20	24	25	32	40
Drilled Hole Dia, d_h (mm)	12	15	20	25	30	30	40	50
Stress Area, A_s (mm ²)	78.5	113	201	314	452	491	804	1260
Yield Stress, f_{sy} (MPa)	500	500	500	500	500	500	500	500
Tensile Steel Yield Capacity, N_{sy} (kN)	39.3	56.5	100.5	157.0	226.0	245.5	402.0	630

For further information refer to reinforcing bar manufacturer's published information and current revision of **AS/NZS 4671**

EPCON™ C8 Xtrem™

FIRE RATED CHEMICAL ANCHOR

Reinforcing Bar Anchored with EPCON™ C8 Xtrem™

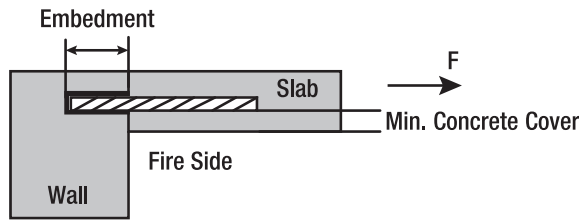

Design Case

1

Fire resistance duration = 30 minutes

For Reinforcing Bar Steel Grade - 500 MPa and Concrete cylinder compressive strength - 20 MPa

Rebar Size	Hole Diameter	*Min. Concrete Cover	Design resistance in accordance with Eurocode 2 for fire duration 30 minutes (kN)													Rebar Max. Load (kN) in case of fire		
			120	160	180	190	200	220	240	250	290	315	320	340	360		400	
10	12	10	6.1	8.1	-	9.6												25.3
12	16	12	7.3	9.7	10.9	-	12.1											36.4
16	20	16		13.0	14.6	-	-	17.8	19.4									64.8
20	25	20		16.2	18.2	-	20.2	22.3	24.3	25.3								101.2
24	30	25								31.6	36.7	39.8						145.8
25	30	25								31.6	36.7	39.8						158.1
32	40	32											51.8	55.0	58.2			259
40	50	40															80.9	404.7
Embedment (mm)			120	160	180	190	200	220	240	250	290	315	320	340	360	400		

* Note: Minimum concrete cover according to Eurocode 2 part 1.2

Design Case

2

Fire resistance duration = 60 minutes

For Reinforcing Bar Steel Grade - 500 MPa and Concrete cylinder compressive strength - 20 MPa

Rebar Size	Hole Diameter	*Min. Concrete Cover	Design resistance in accordance with Eurocode 2 for fire duration 60 minutes (kN)													Rebar Max. Load (kN) in case of fire		
			120	160	180	220	240	250	300	305	320	360**	395	400	445		495	
10	12	20	3.0	8.1	-	11.1												25.3
12	16	20	3.2	9.4	10.9	13.4	14.6											36.4
16	20	20		10.5	14.6	17.8	19.4	-	24.3									64.8
20	25	20		16.2	18.2	22.3	24.3	25.3	-	30.9								101.2
24	30	25						31.6	-	-	-	44.2	50.0					145.8
25	30	25						31.6	-	-	-	44.2	50.0					158.1
32	40	32										51.8	58.2	-	-	72.0		259
40	50	40												80.9	-	100.2		404.7
Embedment (mm)			120	160	180	220	240	250	300	305	320	360**	395	400	445	495		

* Note: Minimum concrete cover according to Eurocode 2 part 1.2

** Note: Values for Rebar Size 24 are based on Embedment = 350 mm

Design method for resistance to fire according to Eurocode 2: Fire proof using design resistance: $R_{d,fi} \leq E_{d,fi}$

$R_{d,fi}$ Design resistance in the fire situation

$E_{d,fi}$ Design effect of actions in the fire situation. This value could be calculated from the calculation at normal temperature:

$$E_{d,fi} = \eta_{fi} \times F_{Rdu}$$

F_{Rdu} Design ultimate limit load at normal temperature for one rebar sealing at the anchorage depth (mm)

η_{fi} Reduction factor for design load level in the fire situation η_{fi} is equal to 0.7.

EPCON™ C8 Xtrem™

FIRE RATED CHEMICAL ANCHOR

Fire Rated Anchoring Systems

Reinforcing Bar Anchored with EPCON™ C8 Xtrem™

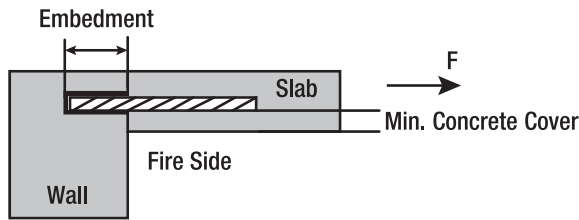

Design Case 3 Fire resistance duration = 90 minutes

For Reinforcing Bar Steel Grade - 500 MPa and Concrete cylinder compressive strength - 20 MPa

Rebar Size	Hole Diameter	*Min. Concrete Cover	Design resistance in accordance with Eurocode 2 for fire duration 90 minutes (kN)													Rebar Max. Load (kN) in case of fire		
			120	160	180	220	250	265	290**	320	335	340	400	440	500		555	
10	12	25	1.7	5.4	-	11.1	-	13.4										25.3
12	16	25	2.1	5.5	8.6	13.4	-	-	17.0									36.4
16	20	25		5.8	8.9	17.8	-	-	22.7	25.9	27.1							64.8
20	25	25		13.4	18.2	22.3	25.3	-	28.4	-	-	34.4						101.2
24	30	25					30.6	-	36.7	-	-	-	-	55.7				145.8
25	30	25					30.6	-	36.7	-	-	-	-	55.7				158.1
32	40	32								51.8	-	55.0	-	71.2	81.1			259
40	50	40											80.9	-	-	112.3		404.7
Embedment (mm)			120	160	180	220	250	265	290**	320	335	340	400	440	500	555		

* Note: Minimum concrete cover according to Eurocode 2 part 1.2

** Note: Values for Rebar Sizes 12, 16 and 20 are based on Embedment = 280 mm

Design Case 4 Fire resistance duration = 120 minutes

For Reinforcing Bar Steel Grade - 500 MPa and Concrete cylinder compressive strength - 20 MPa

Rebar Size	Hole Diameter	*Min. Concrete Cover	Design resistance in accordance with Eurocode 2 for fire duration 120 minutes (kN)													Rebar Max. Load (kN) in case of fire		
			120	160	240	250	290	300	320	355	360	400	440**	460	500		605	
10	12	35	1.2	3.6	12.1	-	14.7											25.3
12	16	35	1.7	3.5	14.6	-	18.2											36.4
16	20	35		4.8	19.4	-	24.3	25.9	28.7									64.8
20	25	35		10.7	24.3	25.3	-	-	-	-	36.4							101.2
24	30	35				24.5	36.7	-	-	-	-	-	55.7	58.2				145.8
25	30	35				24.5	36.7	-	-	-	-	-	55.7	58.2				158.1
32	40	35							51.8	-	58.2	-	71.2	-	81.1			259
40	50	40										80.9	87.0	-	-	122.4		404.7
Embedment (mm)			120	160	240	250	290	300	320	355	360	400	440**	460	500	605		

* Note: Minimum concrete cover according to Eurocode 2 part 1.2

** Note: Values for Rebar Size 40 are based on Embedment = 430 mm

Design method for resistance to fire according to Eurocode 2: Fire proof using design resistance: $R_{d,fi} \leq E_{d,fi}$

$R_{d,fi}$ Design resistance in the fire situation

$E_{d,fi}$ Design effect of actions in the fire situation. This value could be calculated from the calculation at normal temperature:

$$E_{d,fi} = \eta_{fi} \times F_{Rdu}$$

F_{Rdu} Design ultimate limit load at normal temperature for one rebar sealing at the anchorage depth (mm)

η_{fi} Reduction factor for design load level in the fire situation η_{fi} is equal to 0.7

EPCON™ C8 Xtrem™

FIRE RATED CHEMICAL ANCHOR

Reinforcing Bar Anchored with EPCON™ C8 Xtrem™

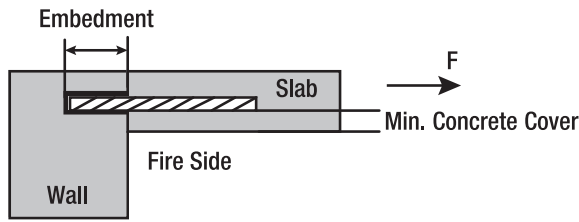

Design Case

5

Fire resistance duration = 180 minutes

For Reinforcing Bar Steel Grade - 500 MPa and Concrete cylinder compressive strength - 20 MPa

Rebar Size	Hole Diameter	*Min. Concrete Cover	Design resistance in accordance with Eurocode 2 for fire duration 180 minutes (kN)													Rebar Max. Load (kN) in case of fire		
			120	160	240	250	300	320	350	395	400	430	500	555	575		655	
10	12	50	1.0	1.9	9.6	-	15.2											25.3
12	16	50	1.5	2.4	10.8	-	18.2	19.4	21.2									36.4
16	20	50		3.6	12.8	-	24.3	25.9	-	32.0								64.8
20	25	50		7.9	24.3	25.3	-	-	-	-	40.5							101.2
24	30	50				17.7	-	-	44.2	50.0	-	-	63.2					145.8
25	30	50				17.7	-	-	44.2	50.0	-	-	63.2					158.1
32	40	50						44.5	-	-	-	-	81.1	-	93.1			259
40	50	50									80.9	87.0	-	112.3	-	132.5		404.7
Embedment (mm)			120	160	240	250	300	320	350	395	400	430	500	555	575	655		

* Note: Minimum concrete cover according to Eurocode 2 part 1.2

Design Case

6

Fire resistance duration = 240 minutes

For Reinforcing Bar Steel Grade - 500 MPa and Concrete cylinder compressive strength - 20 MPa

Rebar Size	Hole Diameter	*Min. Concrete Cover	Design resistance in accordance with Eurocode 2 for fire duration 240 minutes (kN)													Rebar Max. Load (kN) in case of fire		
			120	160	240	250	320	350	375	400	425	500	530	555	605		685	
10	12	70	0.9	1.7	7.8	-	-	17.7										25.3
12	16	70	1.4	2.0	8.0	-	19.4	21.2	22.8									36.4
16	20	70		3.4	9.7	-	25.9	-	-	34.4								64.8
20	25	70		6.9	20.1	21.4	-	-	-	40.5	43.0							101.2
24	30	70				15.1	-	44.2	-	-	-	63.2	67.0					145.8
25	30	70				15.1	-	44.2	-	-	-	63.2	67.0					158.1
32	40	70						37.3	-	-	-	81.1	-	-	97.9			259
40	50	70									80.9	-	-	-	112.3	122.4	138.6	404.7
Embedment (mm)			120	160	240	250	320	350	375	400	425	500	530	555	605	685		

* Note: Minimum concrete cover according to Eurocode 2 part 1.2

Design method for resistance to fire according to Eurocode 2: Fire proof using design resistance: $R_{d,fi} \leq E_{d,fi}$

$R_{d,fi}$ Design resistance in the fire situation

$E_{d,fi}$ Design effect of actions in the fire situation. This value could be calculated from the calculation at normal temperature:

$$E_{d,fi} = \eta_{fi} \times F_{Rdu}$$

F_{Rdu} Design ultimate limit load at normal temperature for one rebar sealing at the anchorage depth (mm)

η_{fi} Reduction factor for design load level in the fire situation η_{fi} is equal to 0.7

ChemSet™ 801 Xtrem™ XC²

FIRE RATED CHEMICAL ANCHOR

[Back to index](#)

Fire Rated Anchoring Systems

GENERAL INFORMATION

Performance Related	Material Specification	Installation Related

Product

Chemset™ 801 Xtrem™ XC² is a heavy duty Vinylester for anchoring threaded studs and reinforcing bar into cracked and uncracked concrete.



Compliance

European Technical Assessment (option 1) - ETA-18/0045

Design according to:

- AS5216 (formerly TS101)
- EN1992-4 (formerly ETAG001 Annex C, E & TR045)
- Use enclosed data for simplified calculation method

Use Ramset™ iExpert Anchor Software for optimised calculation or where a greater range of anchor layout detail is needed.



Benefits, Advantages and Features

- Fire rated - MFPA Leipzig GmbH test no. GS 32/17-410-3
- Flooded Holes

Greater productivity:

- Easy dispensing even in cold weather
- Apply torque in 2 hours @ 20°C

Greater security:

- Strong bond
- Rated for sustained loading

Versatile:

- Earthquake, Fire & Flooded Conditions
- Cold and temperate climates

Greater safety:

- Low odour
- Suitable for contact with drinking water
- VOC Compliant

Made in Australia

Principal Applications

- Threaded Studs
- Starter Bars
- Threaded Inserts
- Over-head installation
- Steel Columns
- Hand Rails
- Road Stitching

Installation

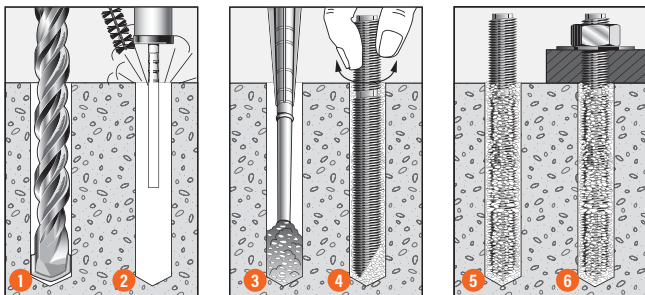

- Drill recommended diameter and depth hole.
- Important:** Use Ramset™ Dustless Drilling System to ensure holes are clean. Alternatively clean dust and debris from hole with stiff wire or nylon brush and blower in the following sequence: blow x 2, brush x 2, blow x 2.
- Dispense adhesive to waste until colour is uniform light grey (2-3 trigger pulls). Insert mixing nozzle to bottom of hole. Fill hole to 3/4 the hole depth slowly, ensuring no air pockets form.
- Insert Ramset™ ChemSet™ Anchor Stud/rebar to bottom of hole while turning.
- Allow Chemset™ 801 Xtrem™ XC² to cure as per setting times.
- Attach fixture.

Recommended Installation Temperatures

	Minimum	Maximum
Substrate	5°C	40°C
Adhesive	5°C	40°C

Service Temperature Limits

-40°C to 80°C

Setting Times

Temperature of base material	Gel Time	Curing time in dry concrete	Curing time in wet concrete
+5°C	60 min	240 min	480 min
6°C - 10°C	40 min	180 min	360 min
11°C - 20°C	15 min	120 min	240 min
21°C - 30°C	8 min	90 min	180 min
31°C - 40°C	4 min	60 min	120 min

Note: Cartridge temperature minimum +5°C

ChemSet™ 801 Xtrem™ XC²

FIRE RATED CHEMICAL ANCHOR

Installation and fire performance details: ChemSet™ 801 Xtrem™ XC² and Gr 8.8 Typical Threaded Rod

Fire Rated Anchoring Systems

Anchor size, d _b (mm)	Installation Details				Optimum dimensions*			Characteristic values of resistance to tension loads in 20 MPa to 50 MPa concrete strength - N _{RR,S,R} (kN) per anchor *			
	Drilled hole diameter, d _s (mm)	Fixture hole diameter, d _f (mm)	Anchor effective depth, h (mm)	Tightening torque, T _r (Nm)	Edge distance, e _c (mm)	Anchor spacing, a _c (mm)	Concrete substrate thickness, b _m (mm)	Fire resistance duration = 30 Min.	Fire resistance duration = 60 Min.	Fire resistance duration = 90 Min.	Fire resistance duration = 120 Min.
M10	12	12	90	20	135	270	120	2.33	1.68	1.04	0.71
M12	14	14	110	40	165	330	140	3.10	2.44	1.79	1.46
M16	18	18	125	95	187	375	160	5.77	4.54	3.33	2.72
M20	22	22	150	180	225	450	190	9.01	7.09	5.2	4.24
			170		255		220				
M24	26	26	160	315	240	480	200	12.9	10.21	7.49	6.11
			210		315		270				
M30	35	33	280	650	420	840	350	20.62	16.23	11.91	9.71

*Note:

Data is valid for Grade 8.8 Typical Threaded only or ChemSet™ Anchor Stud Xtrem™

Data applies to uncracked and cracked reinforced concrete

Data applies to a one-sided fire exposure of the structural elements. For conditions of fire load on several sides, please contact your local Ramset™ engineer

Data is based on concrete cylinder strength between 20 MPa to 50 MPa.

DESCRIPTION AND PART NUMBERS

Description	Cartridge Size	Part No.
ChemSet™ 801 Xtrem™ XC ²	750ml	C801X750 (AU & NZ)
ChemSet™ 801 Xtrem™ XC ²	380ml	C801X380 (AU Only)

ENGINEERING PROPERTIES

ChemSet™ Anchor Studs and Threaded Rod

Anchor Size, d _b	Grade 8.8 Threaded Rod			
	Shank diameter, d _s (mm)	Stressed Area (mm ²)	Yield Strength f _y MPa	UTS f _u MPa
M10	8.6	58	640	800
M12	10.4	84.3	640	800
M16	14.1	157	640	800
M20	17.7	245	640	800
M24	21.2	353	640	800
M30	26.7	561	640	800

Specifiers Resource Book

DESIGN WORKSHEET

[Back to index](#)

Specifiers Resource Book - Design Worksheet

Project _____

Design _____

Location _____

Project ID _____ Date _____

Design by _____ Checked _____

Sketch

Notes

N^* & V^* are the **per anchor** load cases.
Check both external and internal anchors for suitability.

Tensile design action effect	N^*	<input type="text"/>	kN
Shear design action effect	V^*	<input type="text"/>	kN
Fixture thickness	t	<input type="text"/>	mm
Concrete compressive strength	f'_c	<input type="text"/>	MPa
Anchor spacing	a	<input type="text"/>	mm
Edge distance	e	<input type="text"/>	mm
No. of anchors in row parallel to edge	n	<input type="text"/>	
Direction of shear load		<input type="text"/>	degs.

STEP 1 Select anchor to be evaluated

Table 1a Interaction Diagram

Find intersection of N^* and V^* values.
Select anchor size.

Table 1b Absolute minima, a_m & e_m

Check for compliance with absolute minima

Step 1c Calculate effective depth, h

Checkpoint 1

- Anchor size selected?
- Comply with absolute minima?
- Effective depth, h calculated?

Anchor Type

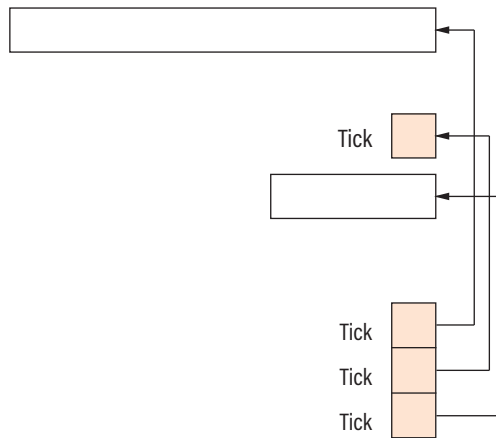

Notes for this application

Specifiers Resource Book

DESIGN WORKSHEET

STEP 2 Verify concrete tensile capacity - per anchor

Table 2a Concrete tensile capacity, ϕN_{uc}

Table 2a-2 Cracked Concrete effect, tension, X_{ncr}

Table 2b Concrete compressive strength effect, X_{nc}

Table 2c Edge distance effect, X_{ne}

Table 2d Anchor spacing effect, external to a row, X_{nae}

Table 2e Anchor spacing effect, internal to a row, X_{nai}

Checkpoint 2

Calculate $\phi N_{urc} = \phi N_{uc} * X_{nc} * X_{ne} * (X_{nae} \text{ or } X_{nai})$

STEP 3 Verify anchor tensile capacity - per anchor

Table 3a Calculate steel tensile capacity, ϕN_{us}

Step 3b Confirm bolt tensile capacity, ϕN_{tf}

Checkpoint 3

$\phi N_{ur} = \text{Minimum of } \phi N_{urc}, \phi N_{us}, \phi N_{tf}$

$N^* / \phi N_{ur} \leq 1.0$?

	/		=	
--	---	--	---	--

If not satisfied return to step 1.

STEP 4 Verify concrete shear capacity - per anchor

Table 4a Concrete shear capacity, ϕV_{uc}

Table 4a-2 Cracked Concrete effect, shear, X_{vcr}

Table 4b Concrete compressive strength effect, X_{vc}

Table 4c Load direction effect, X_{vd}

Table 4d Anchor spacing effect, X_{va}

Table 4e Multiple anchors effect, X_{vn}

Table 4f Anchor at a corner effect, X_{vs}

Checkpoint 4

Calculate $\phi V_{urc} = \phi V_{uc} * X_{vc} * X_{vd} * X_{va} * X_{vn} * X_{vs}$

STEP 5 Verify anchor shear capacity - per anchor

Table 5a Calculate steel shear capacity, ϕV_{us}

Step 5b Confirm bolt shear capacity, ϕV_{sf}

Checkpoint 5

$\phi V_{ur} = \text{Minimum of } \phi V_{urc}, \phi V_{us}, \phi V_{sf}$

$V^* / \phi V_{ur} \leq 1.0$?

	/		=	
--	---	--	---	--

If not satisfied return to step 1.

STEP 6 Combined loading and specification

Checkpoint 6

$N^* / \phi N_{ur} + V^* / \phi V_{ur} \leq 1.2$?

	/	+	/	=	
--	---	---	---	---	--

If not satisfied return to step 1.

Specify

X
X
X
X OR

=

Tick

TENSILE DESIGN COMPLETE D

X
X
X
X
X
X

=

Tick

SHEAR DESIGN COMPLETE D

Tick

DESIGN CHECK COMPLETED

Important Disclaimer: Any engineering information or advice ("Information") provided by Ramset™ in this document is issued in accordance with a prescribed standard, published performance data or design software. It is the responsibility of the user to obtain its own independent engineering (or other) advice to assess the suitability of the Information for its own requirements. To the extent permitted by law, Ramset™ will not be liable to the recipient or any third party for any direct or indirect loss or liability arising out of, or in connection with, the Information.

Customer service

Ramset™ Australia

Sales, Orders and Enquiries

Tel: 1300 780 063

Fax: 1300 780 064

Email: enquiry@ramset.com.au

Web: www.ramset.com.au

Ramset™ New Zealand

Sales, Orders and Enquiries

Tel: 0800 RAMSET (726738)

Fax: 09 444 2864

Email: info@ramsetreid.co.nz

Web: www.ramset.co.nz